

TRANSLATION OF THE ORIGINAL VERSION

CE



Operating Manual

Bandsaw Machines

RAPID 400 / 500 / 600 / 700 / 800 / 900



Machine Type: **Bandsaw Machine Series RAPID 400 - 900**

Reinhold Beck Maschinenbau GmbH
Im Grund 23 | DE -72505 Krauchenwies
Tel.: +49 (0) 7576 / 962 978 - 0 | Fax: +49 (0) 7576 / 962 978 - 90
E-Mail: info@beck-maschinenbau.de | Web: <https://www.beck-maschinenbau.de>

Space for notes:

Reinhold Beck Maschinenbau GmbH
 Im Grund 23, DE 72505 Krauchenwies
 Phone: +49 (0) 7576 962978-0
 Fax: +49 (0) 7576 962978-90

<h2>Handover Certificate</h2>	
Machine type:	
Machine no.:	
Construction year:	
Customer address (location of the machine):	
Name:	
Street:	
Postcode/City:	
Phone:	
E-mail:	
<p>Warranty:</p> <p>On the basis of our Terms and Conditions of Sale, Delivery and Payment of the respective current status, we assume a warranty of 12 months, calculated from the day of delivery, for material defects and defects of title in connection with the delivery for the above-mentioned machine.</p>	
<p>Warranty claims:</p> <p>Warranty claims against R. Beck Maschinenbau GmbH are only valid if this handover declaration has been completed, signed and handed over to R. Beck Maschinenbau GmbH and the machine has been properly put into operation.</p> <p>Important: Please read and follow the instructions in chapter ⇨ 1 "Liability and Warranty".</p>	
<p>Confirmation of the buyer:</p> <ul style="list-style-type: none"> ✓ The machine described above was purchased by the buyer. ✓ The machine was handed over with the corresponding operating manual, edition: _____ ✓ The contents of the operating manual are acknowledged by the buyer. ✓ Persons who are commissioned to work on this machine will be provided with the operating manual and will receive safety training. 	
_____ Name and position	_____ Date
_____ Signature of the customer	
<p>Address of the dealer (company stamp):</p>	<p>The machine, including the operating manual, was handed over to the buyer and installed according to the specifications in the operating manual.</p>
	<p>_____ Date</p>
	<p>_____ Signature - Customer Service</p>

Space for notes:

Reinhold Beck Maschinenbau GmbH
 Im Grund 23, DE 72505 Krauchenwies
 Phone: +49 (0) 7576 962978-0
 Fax: +49 (0) 7576 962978-90

<h2>Handover Certificate</h2>		
Machine type:		
Machine no.:		
Construction year:		
Customer address (location of the machine):		
Name:		
Street:		
Postcode/City:		
Phone:		
E-mail:		
<p>Warranty:</p> <p>On the basis of our Terms and Conditions of Sale, Delivery and Payment of the respective current status, we assume a warranty of 12 months, calculated from the day of delivery, for material defects and defects of title in connection with the delivery for the above-mentioned machine.</p>		
<p>Warranty claims:</p> <p>Warranty claims against R. Beck Maschinenbau GmbH are only valid if this handover declaration has been completed, signed and handed over to R. Beck Maschinenbau GmbH and the machine has been properly put into operation.</p> <p>Important: Please read and follow the instructions in chapter ⇨ 1 "Liability and Warranty".</p>		
<p>Confirmation of the buyer:</p> <ul style="list-style-type: none"> ✓ The machine described above was purchased by the buyer. ✓ The machine was handed over with the corresponding operating manual, edition: _____ ✓ The contents of the operating manual are acknowledged by the buyer. ✓ Persons who are commissioned to work on this machine will be provided with the operating manual and will receive safety training. 		
_____ Name and position	_____ Date	_____ Signature of the customer
Address of the dealer (company stamp):	<p>The machine, including the operating manual, was handed over to the buyer and installed according to the specifications in the operating manual.</p> <div style="text-align: right; margin-top: 20px;"> _____ Date </div> <div style="text-align: right; margin-top: 10px;"> _____ Signature - Customer Service </div>	

Table of Contents

1	Liability and Warranty	10
2	Introduction.....	11
2.1	Legal Notice.....	11
2.2	Illustrations	11
3	Symbols	11
3.1	General Symbols	11
3.2	Symbols in Safety Instructions.....	12
4	General	13
4.1	Structure of the Machine	13
4.2	Target Group and Previous Experience	13
4.3	Requirements for the Operators	13
4.4	Accident Prevention	14
4.5	General Safety Regulations	14
4.6	Machine Description	14
4.7	About the RAPID 400 - 900 Series	15
4.8	Standard Equipment	15
4.9	Available Accessories	15
5	Safety.....	16
5.1	Basic Safety Instructions.....	16
5.1.1	Application Area and Intended Use	16
5.1.2	Modifications and Conversions to the Machine	16
5.1.3	Connection to a Central Emergency Stop Switch.....	16
5.1.4	Residual Risks	17
5.1.5	Observe the Environmental Protection Regulations.....	18
5.1.6	Organisational Measures.....	18
5.1.7	Personnel Selection and Qualification - Basic Duties.....	19
5.2	Safety Instructions for Specific Phases of Operation	19
5.2.1	Before starting Work	19
5.2.2	Normal Operation	19
5.2.3	Special work within the Scope of Maintenance Work as well as Troubleshooting in the Workflow	20
5.2.4	Safe Working Practices	21
5.2.5	Safety Equipment	21
5.2.6	Noise	21
5.3	Danger Zones on the Bandsaw	22
5.3.1	Danger Zone Bandsaw Blade	22
5.3.2	Danger Zone around the Machine.....	22
6	Machine Data	23
6.1	Series and Expandability	23
6.2	Technical Specifications	24
6.3	Dimensions.....	24
6.4	Emission Levels according to EN ISO 3746:2010	25
6.4.1	Noise Information.....	25
6.4.2	Noise Emission Values	25
6.4.3	Dust Emission according to GS-HO-05 in mg/m ³ air (permissible max. 2.0 mg/m ³ air)	25
6.4.4	Extraction	25

7	Installation and Connection	26
7.1	Check Delivery Conditions	26
7.2	Transport to the Installation Site	26
7.2.1	Transport of Models RAPID 400 - 700	26
7.2.2	Transport of Models RAPID 800 - 900	26
7.3	Pre-Assembly	26
7.3.1	Pre-Assembly of Models RAPID 400 - 700	26
7.3.2	Pre-Assembly of Models RAPID 800 and 900	26
7.4	Installing the Machine	27
7.5	Temporary Storage	27
7.6	Lashing on a Transport Vehicle	27
7.6.1	Lashing Models RAPID 400 / 500 / 600	28
7.6.2	Lashing Models RAPID 700 / 800 / 900	28
7.7	Connecting the Extraction Unit	29
7.8	Electrical Connections	30
8	Components and Controls	31
9	Commissioning	32
9.1	Switching ON and OFF	32
9.1.1	Switch on 2.2 kW Models	32
9.1.2	Switch on 3.0 - 7.5 kW Models	32
9.1.3	Switch on Machines with Electric Brake	33
9.1.4	Switching on with Variable Saw Blade Speed Control (Option)	34
9.2	Frequent switching ON and OFF in succession	34
10	Settings and Operation	35
10.1	Basic Factory Setting	35
10.2	Door Interlock with Safety Switches	35
10.3	Inserting and Tensioning a Bandsaw Blade	36
10.4	Adjusting the upper Bandsaw Wheel	37
10.5	Height adjustment of the upper Saw Blade Guide	37
10.6	Swivel Table	37
10.7	Adjusting the GL Bandsaw Guides	38
10.7.1	Structure and Components	38
10.7.2	Adjusting the GL Saw Blade Guides	38
10.7.3	Basic Setting of the Back and Side Rollers (Overview)	39
11	Using the Rip Fence	40
11.1	Convert the Fence to the Right of the Saw Blade	40
12	Replace Table Insert	40
13	General Instructions for Use	41
13.1	Bandsaw Blades	41
13.2	Use of the Machine	41
13.3	Completion of the Work	43
14	Optional Components	44
14.1	APA 2 - Saw Blade Guides	44
14.1.1	Structure and Components	44
14.1.2	Adjusting the APA Saw Blade Guides	44
14.1.3	Basic Setting of the Back and Side Rollers (Overview)	45
14.1.4	Conversion to Left Version	45

14.2	Variable Saw Blade Speed Control	46
14.3	Measurement Scale on the Table	46
14.4	Table Swivel Device	46
14.5	Mitre Fence "Top"	47
14.6	Mitre Fence "Basic"	47
14.7	Table Extension	47
14.8	Kreisfix for Circular Cuts	47
14.9	Machine Moving Trolley	48
14.10	Emergency Stop Switch	48
14.11	Laser Cut Position Indicator (Option for RAPID 600 - 900)	48
14.11.1	Special Features of Use	48
15	Troubleshooting	49
15.1	Machine - Troubleshooting	49
15.2	Saw Blade Guides - Troubleshooting	50
15.3	Behaviour in the event of a power failure	51
16	Maintenance and Inspection	52
16.1	Replace Ball Bearings	52
16.2	Lubrication of the Machine	53
16.3	Maintenance and Lubrication of the Saw Blade Guides	53
16.3.1	Oil "GL" Saw Blade Guides	53
16.3.2	Oil "APA" Saw Blade Guides	53
16.4	Bandsaw Roll Coating	54
16.5	Replacing the Bandsaw Blade	54
16.6	Retighten the V-belt(s)	55
16.7	Replacing the V-belt(s)	55
16.8	Readjusting the Main Motor Brake (2.2 - 3.0 kW)	56
16.8.1	Check the Adjustment	56
16.9	Readjusting the Main Motor Brake (4.0 - 7.5 kW)	56
16.10	Models with Electric Motor Brake	56
17	Disassembly and Scrapping	57
18	Options and Accessories	58
18.1	RAPID 400 - Bandsaw Blades	58
18.2	RAPID 400 - Options and Accessories	58
18.3	RAPID 500 - Bandsaw Blades	59
18.4	RAPID 500 - Options and Accessories	59
18.5	RAPID 600 - Bandsaw Blades	60
18.6	RAPID 600 - Options and Accessories	60
18.7	RAPID 700 - Bandsaw Blades	61
18.8	RAPID 700 - Options and Accessories	61
18.9	RAPID 800 - Bandsaw Blades	62
18.10	RAPID 800 - Options and Accessories	62
18.11	RAPID 900 - Bandsaw Blades	63
18.12	RAPID 900 - Options and Accessories	63
	EU - Declaration of Conformity	64

List of Figures

Figure 1: Bandsaw blade	11
Figure 2: Danger zone saw blade	22
Figure 3: Danger zone around the machine	22
Figure 4: Nameplate	23
Figure 5: Series RAPID 400 - 900	23
Figure 6: Dimensions	24
Figure 7: Transport	26
Figure 8: Crane eyelet	26
Figure 9: Attach protective cover	26
Figure 10: Lashing models RAPID 400 / 500 / 600	28
Figure 11: Lashing models RAPID 700 / 800 / 900	28
Figure 12: Suction nozzles	29
Figure 13: Control cabinet (option)	30
Figure 14: Connections	30
Figure 15: Components and controls	31
Figure 16: Machine switch (2.2 KW)	32
Figure 17: Machine switch (3.0 - 7.5 kW)	32
Figure 18: Push-switch unit (3.0 - 3.5 kW)	33
Figure 19: Push-button unit (1.1 - 1.5 kW)	33
Figure 20: Push-switch unit (1.5 - 2.2 kW)	33
Figure 21: Panel with variable speed control	34
Figure 22: Factory adjustment points	35
Figure 23: Safety switch - door unlocked	35
Figure 24: Safety switch - door locked	35
Figure 25: Overview - Inserting and tensioning the bandsaw blade	36
Figure 26: Bandsaw wheel adjustment	37
Figure 27: Lever for height adjustment	37
Figure 28: Adjust table inclination	37
Figure 29: GL 456 - Structure and components	38
Figure 30: Adjusting the GL saw blade guides	38
Figure 31: Basic adjustment of the back and side rollers	39
Figure 32: Fence in high position	40
Figure 33: Fence turned to flat position	40
Figure 34: Converting the fence for left-handers	40
Figure 35: Table insert	40
Figure 36: Table extensions and tools	42
Figure 37: APA - Structure and components	44
Figure 38: Adjusting the guides	44
Figure 39: Basic adjustment of the back and side rollers	45
Figure 40: Convert bottom guide to left	45
Figure 41: Convert top guide to left	45
Figure 42: Blade speed control	46
Figure 43: Measurement scale on the table	46
Figure 44: Adjust the table Inclination	46
Figure 45: Mitre fence "Top"	47
Figure 46: Mitre fence "Basic"	47
Figure 47: Table extension	47
Figure 48: Kreisfix for circular cuts	47
Figure 49: Machine moving trolley	48
Figure 50: Laser device	48
Figure 51: Laser cutting edge	48
Figure 52: Special oil 1059	53
Figure 53: Oil GL saw blade guides	53
Figure 53: Oil APA side rollers	53
Figure 54: Oil APA back roller	53
Figure 55: Retension the V-belt(s)	55
Figure 56: Replacing the V-belt(s)	55
Figure 57: Readjusting the motor brake	56

Revisions:

Revision	Editor	Modification	Date
000	AG	Original manual translated	08/11/2021
001	AG	⇒ 5.2.2 Bottom point adjusted ⇒ 5.2.4 Bottom point deleted ⇒ 5.2.5 Third point from bottom adjusted Section ⇒ 15.3 newly added	23/11/2023

1 Liability and Warranty

When purchasing a machine or work equipment (hereinafter referred to as "machine"), the General Terms and Conditions of Sale and Delivery of Reinhold Beck Maschinenbau GmbH generally apply. These are provided to the purchaser or operator at the latest when the contract is concluded.



IMPORTANT NOTE: Liability and warranty claims shall only commence from the point in time at which the signed handover certificate (see ⇒ page 3 resp. page 5) from the dealer and/or end customer for the delivered machine has been submitted to Reinhold Beck Maschinenbau GmbH in written form.

Liability and warranty claims for personal injury and property damage are generally excluded if they are due to one or more of the following causes:

- Commissioning of the machine without prior machine instruction by an authorised and adequately trained specialist who is familiar with the function and dangers of the machine.
- Electrical connection as well as repair and/or maintenance work on electrical components by personnel who do not have the appropriate qualifications.
- Connection and repair and/or maintenance work on hydraulic or pneumatic components by personnel who do not have the appropriate qualifications.
- Non-observance of the instructions in the operating manual, in particular the chapter "Safety".
- Improper use or operation in an unauthorised area of application.
- Improper assembly, commissioning, operation and maintenance of the machine.
- Unauthorised conversions or modifications to the machine or additional components.
- Operating the machine without using all the protective equipment available for the operation.
- Inadequate monitoring and maintenance of the machine components and protective devices.
- Continuing to operate the machine when faults, damage or defects are present.
- Processing materials that do not correspond to the machine's area of application.
- Carrying out operations that are not permitted for the machine supplied.
- Use of tools that are not permitted for the machine supplied.
- Operating the machine outdoors or in damp, wet or potentially explosive environments.
- Operation of the machine outside permissible ambient temperatures or humidity.
- Grossly negligent behaviour when handling or operating the machine.
- Impact by foreign bodies, e.g. stones, metal parts, etc.
- Improperly carried out repairs.
- Catastrophic events due to force majeure.

2 Introduction

This operating manual covers all bandsaw machines of the series RAPID 400 to 900. The purpose of this document is to acquaint the user with the machine and enable him to use it to the full extent of its intended capabilities.

Additionally it contains important information to operate the machine safely, properly and economically.

Observance of the manual helps to avoid hazards, reduce repair costs and downtimes and increase the reliability and service life of the machine.

Furthermore, this operating manual serves to supplement instructions based on national regulations for accident prevention and environmental protection.

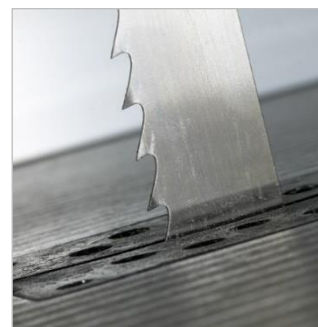



Figure 1: Bandsaw blade

	<p><i>This operating manual must always be available at the place of use of the machine. It must be read and followed by every person who is assigned to work on the machine, e.g.</i></p> <ul style="list-style-type: none"> • <i>during operation, including set-up, troubleshooting in the work process, removal of production waste and maintenance,</i> • <i>during maintenance (servicing, inspection, repair)</i> • <i>and/or during transport.)</i>
---	---

Apart from the operating manual and the legally binding accident prevention provisions applicable in the country and place of use, the recognized technical regulations for safe and proper work must also be observed.

2.1 Legal Notice



All contents of these operating instructions are subject to the rights of use and copyright of Reinhold Beck Maschinenbau GmbH. Any reproduction, modification, further use and publication in other electronic or printed media, as well as their online publication, requires the prior written consent of Reinhold Beck Maschinenbau GmbH.

2.2 Illustrations















All photos, figures and graphics contained in this document are for illustration and better understanding only and may differ from the current state of the product.

3 Symbols

3.1 General Symbols

Symbol	Meaning
	Indicates passages within this operating manual that must be particularly observed in order to prevent malfunctions or damage to the lift table.
	Refers to chapters, sections, or figures within this document.
	Refers to an external document or a third-party source.

3.2 Symbols in Safety Instructions

Symbol	Safety Instruction
	General danger symbol, which requires the highest attention! <i>Failure to observe may result in damage to the equipment, serious injury or even death.</i>
	Warning of possible danger from forklift traffic! <i>Non-observance may result in life-threatening injuries.</i>
	Warning indicates a possible hazard under suspended loads! <i>Non-observance may result in life-threatening injuries.</i>
	Warning indicates a possible fall hazard! <i>Non-observance of these instructions may result in serious injuries.</i>
	Warning indicates a possible cutting hazard! <i>Risk of personal injury and possibly additional damage to equipment.</i>
	Reference to the obligation to wear protective gloves! <i>Non-observance of these instructions may result in personal injury.</i>
	Reference to the obligation to wear hearing protection! <i>Non-observance of these instructions may result in personal injury.</i>
	Reference to the obligation to wear protective goggles! <i>Non-observance of these instructions may result in personal injury.</i>
	Reference to the obligation to wear a respiratory protection mask! <i>Non-observance of these instructions may cause breathing difficulties and lung damage.</i>
	Reference to the obligation to wear safety shoes! <i>Non-observance of these instructions may result in personal injury.</i>
	Possible dangerous crushing hazard in the area of stationary objects! <i>Risk of personal injury and possibly additional equipment damage.</i>
	Reference to a possible crushing hazard! <i>Non-observance increases the risk of injury to hands and fingers!</i>
	This symbol warns of the dangers of electric voltage! <i>Failure to observe may result in damage to the equipment, serious injury or even death.</i>
	Fire hazard! Do not smoke and do not ignite open fire.
	Access for unauthorized persons prohibited! <i>Risk of personal injury and possibly additional equipment damage.</i>
	This safety notice indicates a possible dangerous pull-in hazard! Wearing loose clothing, jewellery as well as long untied hair is prohibited! <i>Risk of personal injury and possibly additional damage to property.</i>

4 General

This Bandsaw machine was produced by Reinhold Beck Maschinenbau GmbH according to the current state of the art and placed on the market as a complete machine. All legal and normative regulations were observed.

4.1 Structure of the Machine

- Wheel diameter, cutting height, cutting width and blade speed vary depending on the model. The exact values for your machine can be found in the section ⇒ 6.2 “Technical Specifications”.
- The lower bandsaw wheel is driven by a three-phase motor and transmits the rotary motion to the bandsaw blade. The bandsaw wheels are provided with a wear and tear resistant lining of high durability.
- The upper bandsaw wheel is spring-mounted and can be adjusted via a hand wheel. This allows the machine to be optimally adjusted to the bandsaw blade.
- To guide the workpieces, a table fence is provided, which is mounted to the left of the saw blade.
- As protection against the saw blade and flying chips, the upper bandsaw guide is equipped with a guard.
- The control panel is used to start the bandsaw and to release the motor brake (depends on equipment).
- The height adjustment of the upper bandsaw guide and saw blade guard is done manually via a 3-arm lever (see section ⇒ 10.5).
- Models with push-button or push-switch unit have an emergency stop as standard. For all other models, an emergency stop switch is available as an option (see chapter ⇒ 18).

4.2 Target Group and Previous Experience

This operating manual is intended for the operating and maintenance personnel of the machine. The operating personnel is to be determined by the operator and must further meet the following requirements:

- Basic technical knowledge (e.g. apprenticeship as carpenter, machine fitter, etc. and/or practice in operating woodworking machines)
- Reading and understanding these operating and maintenance instructions

In order to acquire the knowledge required to operate this machine, the operator must ensure the following measures:

- Product training for every operator (also possible external personnel)
- Regular safety instruction

4.3 Requirements for the Operators

- The bandsaw machine may only be operated by trained personnel who have also read this manual.
- Inspection, maintenance, cleaning and repair may only be performed by technical specialists with product-specific training and mechanical and/or electrical training.
- Specialists with product-specific training are to be commissioned and held responsible for planning and checking the work.
- The national protective regulations for employees must be observed .
- The operator is responsible for the safe use of the machine.
- The legal minimum age must be observed.

4.4 Accident Prevention

To avoid accidents, the following rules must be observed for operation:

- Prevent unauthorized persons from gaining access to the machine.
- Keep unauthorized persons away from the danger areas.
- Repeatedly inform present other persons about existing residual risks (see ⇒ 5.1.4).
- Conduct and record regular training & instruction for persons who must be in the area of the machine.
- New employees must be trained internally to work on a thickener and this training must be documented.

4.5 General Safety Regulations

In general, the following safety regulations and obligations apply when handling the bandsaw machine:

- The bandsaw machine may only be operated in a technically perfect and clean condition.
- It is prohibited to remove, modify or bypass any protective, safety or monitoring equipment.
- It is forbidden to modify or alter the machine without the written approval of the manufacturer / supplier.
- Faults or damage must be reported to the operator immediately, eliminated without delay and repaired if necessary.
- For repairs, only original spare parts may be used.
- All protective, safety and monitoring devices must be regularly checked and maintained by the operator.
- Only instructed, trained or qualified persons may work on this machine.
- Maintenance work must be carried out and documented in accordance with the maintenance instructions.
- After maintenance or repair, the machine may only be started with all protective devices fitted. A responsible person must be defined for this purpose, who checks that the guards have been properly installed.
- For the operation of a bandsaw machine, the respective national safety regulations for employees as well as the national safety and accident prevention regulations apply.

4.6 Machine Description

The bandsaws of the RAPID 400 - 900 series are modern and spacious bandsaws suitable for cutting (cross-cutting and splitting) wood and similar materials. The tool is a toothed steel band to which the cutting movement is transmitted by two band rollers.

After actuating the main switch, the drive motor drives the lower flywheel. All operating elements as well as the emergency stop switch are easily accessible from the machine operator's workplace.

The machine operator transfers the cutting movement to the workpiece, either manually or by means of additional auxiliary or pushing devices. The adjustable guard reduces the risk of contact with the working tool.

4.7 About the RAPID 400 - 900 Series

Bandsaw machines of the RAPID 400 - 900 series are available in different versions. They basically differ in their sizes and wheel diameters as well as in the possible cutting heights and cutting widths. This enables them to be individually adapted to different areas of application.

A torsion-free double-chamber welded construction forms the basis for all functional elements. Both safety doors are secured by safety switches and can only be opened after manual unlocking. The finely planed work table made of grey cast iron is generously dimensioned. It allows safe, precise and economical working.

The material fence is particularly stable and equipped with a practical quick-clamping device. The proven GL saw blade guide ensures optimum cutting results. Optionally, the machine can be equipped with the APA 2 precision bandsaw blade guide.

4.8 Standard Equipment

- Machine stand in torsion-free double-chamber welded steel construction
- Both doors are protected by safety switches
- Three-phase motors with different outputs from 1.1 to 5.5 kW¹
- Finely planed machine table made of cast iron
- Swivelling table up to 45°
- Replaceable table insert
- Fence ruler can be used to the left and right of the saw blade, fence profile can be folded over
- Dynamically balanced bandsaw wheels with vulcanised rubber bandages, cambered for the use of narrow blades for curved cuts from 6 mm upwards
- 1 bandsaw blade, suitable for your machine
- Blade tension indicator with viewing window for setting the recommended tension
- With upper and lower bandsaw blade guide GL (type depends on model).
Optional upper and lower precision bandsaw blade guides APA 2,
Size 1 (RAPID 400/500) and Size 2 (RAPID 600 – 900)
- Mechanical height adjustment of saw blade guard by hand wheel with locking pinion
- Integrated saw blade guard
- Scraper brush and chip catcher on the lower wheel
- RAPID 400 - 500:
Push-button switch for start/stop with motor protection relay; wear-free, electric motor brake
- RAPID 600 - 900:
From 2.2 kW with rotary cam switch with direct starting, from 3.0 kW with star-delta starting, mechanical motor brake and motor protection relay
- Push stick with bracket on machine housing
- CE-compliant and GS-tested

4.9 Available Accessories

- Suitable saw blades, special accessories and optional components can be found in chapter ⇨ 18.

¹ Depending on machine type

5 Safety

5.1 Basic Safety Instructions

Woodworking machines can be dangerous if used improperly. Therefore, observe the safety instructions listed in this chapter and the accident prevention regulations of your employer's liability insurance association!

	<i>The manufacturer accepts no liability for damage and malfunctions resulting from failure to observe these operating instructions.</i>
---	---

5.1.1 Application Area and Intended Use

	<p><i>The bandsaws RAPID 400 - 900 are designed exclusively for cutting (coping and splitting) materials for which the respective bandsaw blade used is suitable (e.g. wood or other materials with the same physical and technical properties).</i></p> <p><i>This machine is not suitable for working on metal or scrap wood - which could contain nails, screws and other metal parts.</i></p> <p><i>The machine may only be operated on a level, firm surface with a sufficiently high minimum load corresponding to the weight of the machine (refer to section ⇒ 6.2).</i></p>
---	---

Other materials such as cork, rubber, hard plastics, bones, etc. can also be processed. Check whether the saw blade used is suitable for cutting these materials. Cutting these materials may require special safety measures, even if there is no obvious danger.

Any processing of other materials requires prior consultation with the manufacturer and his approval.

	<i>Improper use can lead to danger to persons and to a defect or damage to the machine.</i>
---	--

	<i>Only bandsaw blades recommended by the manufacturer are permitted.</i>
---	--

The machine is not suitable for operation outdoors or in potentially explosive environments.

- Permissible ambient temperature: - 15 ... +40° C
- Permissible humidity: 30 ... 90 %

Intended use also includes connecting the machine to an adequately dimensioned extraction system and observing the operating, maintenance and servicing conditions specified in the operating manual. Any other use is considered improper and is prohibited.

5.1.2 Modifications and Conversions to the Machine























	<i>Unauthorised conversions and modifications to the machine are strictly prohibited for safety reasons. This will invalidate the CE declaration of conformity! The manufacturer is not liable for any resulting damage. The risk for this is borne exclusively by the operator/user.</i>
---	--





5.1.3 Connection to a Central Emergency Stop Switch

In workshops where the bandsaw is to be connected to a central emergency stop switch (e.g. school facilities), it should be noted that bandsaw models with electric motor brake are not suitable for this purpose. If an emergency release is triggered externally, the motor brake is no longer supplied with power. Therefore, the bandsaw blade continues to run unbraked until it comes to a standstill.

5.1.4 Residual Risks

The machine is built according to the latest state of the art and the recognised safety rules. Nevertheless, the use of the machine may cause danger to life and limb of the user or third parties or damage to the machine and other equipment. Due to the construction of the machine, the following residual risks can occur even when used as intended and despite compliance with all relevant safety regulations:

	Reading and applying the operating manual is mandatory for the operating personnel.
	Be alert to possible crushing hazards: a) when transporting the machine by forklift truck → between forks & pallet / machine b) when picking up the machine → between machine / pallet and floor c) when lowering the machine → between machine and fixed equipment
	Be alert to possible crushing hazards when lowering the machine (from the cargo pallet to the floor) with a forklift truck or overhead crane.
	Make sure that no objects fall from the forklift truck / crane. Do not leave any objects / tools on the machine.
	It is strictly prohibited to ride on the machine during a lifting operation (with the indoor crane or forklift). There is a danger of falling!
	Unauthorised persons are not allowed to enter the installation area of the machine (responsibility of the operator).
	Be aware of possible tripping and slipping hazards on the floor. Prevent possible hazards by keeping the floor dry and clean and by using anti-slip floor coverings around the machine.
	Be aware of the danger from falling objects such as workpieces, tools or similar. Therefore, wear safety shoes, especially when transporting and setting down the machine.
	Pay attention to the existing danger of being cut by the bandsaw blade. Never reach into the running bandsaw blade! Use pushing devices for short and thin workpieces. Wear protective gloves when changing the saw blade.
	Be aware of the danger of snow from chips and splinters and never remove them from the danger area by hand. Use suitable aids, e.g. hand brushes.
	Danger of cutting and drawing in! Do not clean the bandsaw blade or bandsaw roller with a brush or scraper held in your hand while the machine is running.
	Danger of cutting and drawing in! In case of a broken bandsaw blade or belt, wait until the machine has come to a complete standstill and only then open the separating safety device.
	Be aware of a possible danger of being drawn in by moving machine parts or tools. This can cause pieces of clothing or hair to be caught. Always wear tight-fitting clothing and a hair net if necessary. Generally avoid jewellery, loose clothing and untied long hair.
	Danger from electric shock! There are hazards when working on the electrical system. This work must only be carried out by qualified personnel!
	Danger from electric shock! It is strictly forbidden to bypass safety devices (e.g. safety switches).
	Electrical equipment must be maintained and cleaned regularly.
	Pay attention to the danger of crushing on workpiece guides and moving machine parts.
	Make sure that no unauthorised persons are in the area of the machine.
	Be aware of the risk of injury from flying tool parts in the event of tool breakage. Therefore wear protective goggles.
	Be aware of the risk of injury from flying workpiece parts and chips, splinters and dust coming out of the machine. Therefore wear protective goggles.
	Be aware of the increased noise emission and wear hearing protection.
	Be aware of the increased dust generation. Use the extraction system and wear a dust mask if necessary.













	An existing emergency stop button must always be freely accessible and must not be blocked. Check the function of the emergency stop button daily (before commissioning the system).
	Laser warning: The machine can be optionally equipped with a laser cut position indicator. Looking directly into the laser beam will cause serious eye injury!
	Danger from ejecting parts (e.g. in case of tool breakage)! Avoid being in the danger zone to the right of the saw blade. A cracked bandsaw blade can dangerously fling out and cause the most serious injuries.
	Fire hazard due to wood dust in connection with flying sparks and/or open fire!

5.1.5 Observe the Environmental Protection Regulations

During all work with the machine, the environmental protection regulations, obligations and laws for waste avoidance and proper recycling and/or disposal applicable at the place of use must be observed. This applies in particular to installation, repair and maintenance work involving substances that could pollute the groundwater (e.g. hydraulic oils and cleaning agents and liquids containing solvents). In any case, prevent them from seeping into the ground or entering the sewage system.

	Store and transport the above-mentioned hazardous substances only in suitable containers. Avoid leakage of hazardous substances by using suitable collection containers. Ensure that the above-mentioned substances are disposed of by a qualified disposal company.
---	---



5.1.6 Organisational Measures

-  Always keep this operating manual within easy reach and at the place of use of the machine.
-  In addition to the operating manual, observe and instruct on generally applicable legal and other binding regulations for accident prevention and environmental protection.
-  Supplement the operating manual with further instructions, including supervisory and reporting duties, to take account of special operational features (e.g. with regard to work organisation, work processes, personnel employed).
-  Before starting work on the machine, the person responsible for its operation must have read the operating instructions, especially the chapter "Safety Instructions". This applies in particular to personnel who only occasionally work on the machine.
-  Check that work is carried out in a safety-conscious and hazard-conscious manner and in compliance with the operating manual.
-  Operators must not wear open long hair, loose clothing or jewellery (including rings). There is a risk of injury, e.g. by getting caught or drawn in.
-  Observe the safety instructions and danger warnings on the machine and keep them complete and in legible condition.
-  In case of safety-relevant changes to the machine or its operating behaviour, shut down the entire system immediately and report the fault to the responsible office/person.
-  Use personal protective equipment as necessary or required by regulations.
-  Do not make any modifications, additional attachments or conversions to the machine without the manufacturer's approval! This will compromise safety and invalidate the manufacturer's warranty and any liability claim. The same also applies to the installation and adjustment of safety devices and valves and to welding work on load-bearing part.
-  Spare parts must meet the technical requirements specified by the manufacturer. The exclusive use of original spare parts ensures this. Therefore, only use original spare parts from the manufacturer.
-  Observe the fire alarm and firefighting possibilities. Make the location and operation of fire extinguishers (fire class ABC) known. Do not use water!

5.1.7 Personnel Selection and Qualification - Basic Duties

- ⚠ The machine design and operation is intended for right-handers.
- ⚠ Work on and with the machine may only be carried out by reliable personnel. Observe the legal minimum age!
- ⚠ Only use trained or instructed personnel. Clearly define the responsibilities of the personnel for operating, setting up, maintaining and repairing!
- ⚠ Ensure that only authorised personnel work on the machine!
- ⚠ If personnel to be trained or apprenticed have to work on the machine, this may only be done under the constant supervision of an experienced resp. qualified person.
- ⚠ Work on the electrical equipment of the machine may only be carried out by a qualified electrician or by untrained persons under the direction and supervision of a qualified electrician in accordance with the electrotechnical regulations.

5.2 Safety Instructions for Specific Phases of Operation

	<i>Defects and damage to the machine are to be reported immediately after detection.</i>
	<i>Any mode of operation that compromises safety is prohibited!</i>
	<i>Sufficient lighting (at least 500 lux) around the machine must be ensured!</i>

5.2.1 Before starting Work

- ⚠ Only use sharp, crack-free and sufficiently set bandsaw blades.
- ⚠ Check that the saw blade is correctly aligned on the bandsaw roll.
- ⚠ Check bandsaw guide for correct adjustment (back roller, lateral guide rollers).
- ⚠ Adjust saw blade guard to workpiece height.
- ⚠ Make sure that the cut for the saw blade in the table insert is as narrow as possible.
- ⚠ Keep the necessary aids (e.g. table fence, push stick, push-block, support bracket etc.) ready and use them if necessary.
- ⚠ Keep the floor in the movement area around the machine free of tripping hazards.
- ⚠ Provide containers for waste.
- ⚠ Wear close-fitting clothing.
- ⚠ Wear safety shoes and ear protection.
- ⚠ Wear protective gloves when changing the bandsaw blade.
- ⚠ If gloves are required when handling workpieces, they must be fingerless.

5.2.2 Normal Operation

- ⚠ **Guards:** Take measures to ensure that the machine can only be operated in a safe and functional condition. Only operate the machine when all guards and safety-related devices such as
 - detachable guards,
 - emergency stop units,
 - noise insulations,
 - extraction system
 are available and functional.
- ⚠ **Workpiece:** Before the operation, check the workpiece for
 - foreign inclusions
 - knots
 - twists (contortions) and other irregularities.

- ⚠ **Machine condition:** Check the machine for externally visible damage and defects at least once per shift! Any changes that have occurred (including those in the operating behaviour) must be reported immediately to the responsible office or person! If necessary, stop and secure the machine immediately!
- ⚠ **Extraction:** The machine must be connected to an effective extraction system. This requires a flow velocity of at least 20 m/s for dry chips and 28 m/s for moist chips (moist 18% or more).
- ⚠ **Work area:** An obstacle-free work area around the machine is essential for safe operation. The floor should be level, well maintained and free from debris such as chips and cut-off workpieces.
- ⚠ **Cutting area during operation:** Never try to remove splinters, chips or other parts from the cutting area while the machine is running! Never remove splinters and chips by hand!
- ⚠ **Special tools:** For certain operating phases and operations it is necessary to use special tools for workpiece feeding (e.g. table fence, push stick, push-block, support bracket etc.).
 - When cutting upright workpieces, secure them against tilting, e.g. by means of a stop bracket, table fence, push-block.
 - Secure round workpieces with wedge support or similar against twisting.
 - For very short or narrow workpieces use a suitable pushing device.
 - Ensure good workpiece support for long or wide workpieces, e.g. with a table extension.
 - Do not machine unshaped workpieces that do not fit on the machine table.
- ⚠ **Work interruptions:** Switch off the machine even during short interruptions! Never leave the machine running unattended!
- ⚠ **When the work is finished:** Release the saw blade tension and provide the machine with a warning sign. Lower the saw blade guard to table height.
- ⚠ **Leaving the machine:** Switch off the control voltage and main switch before leaving the machine. Never leave the machine unattended in an unsecured state.
- ⚠ **Behaviour in the event of a saw blade breakage:** Switch the machine off (or optionally press the emergency stop) and wait until all band saw wheels have come to a complete standstill before taking any further action. Only the lower wheel is braked! In the danger zone next to the machine (see ⇒ Figure 3), there is a danger to life if the saw blade breaks!

5.2.3 Special work within the Scope of Maintenance Work as well as Troubleshooting in the Workflow

- ⚠ Observe maintenance and inspection activities prescribed in the operating manual!
- ⚠ These activities, as well as all other repair work, may only be carried out by qualified personnel!
- ⚠ For all work concerning operation, production adjustment, conversion or setting of the machine and its safety-related equipment as well as maintenance and repair, observe switch-on and switch-off procedures according to the operating manual and instructions for maintenance work!
- ⚠ Secure the machine against unexpected restarting during maintenance and repair work.
 - **Lock the main switch with a padlock!**
- ⚠ Always tighten screw connections that have been loosened during maintenance and repair work!
- ⚠ If it is necessary to dismantle safety equipment during set-up, maintenance and repair, the safety equipment must be reassembled and checked immediately after completion of the maintenance and repair work!
- ⚠ Ensure safe and environmentally friendly disposal of operating and auxiliary materials (e.g. oils) and replacement parts (e.g. electronic components)! Refer to chapter ⇒ 17 "Disassembly and Scrapping".

5.2.4 Safe Working Practices

- ⚠ Whenever possible, a push stick or a comparable aid must be used to feed the workpiece. It is essential to avoid working with the hands near the saw blade.
- ⚠ When cutting narrow workpieces, generally use a push stick.
- ⚠ Use aids such as auxiliary fence and push handle for concealed cuts.
- ⚠ Use an aluminium profile rail with a narrow contact edge for cutting narrow and low laths.
- ⚠ Always work with all protective devices! These must be in the intended places and in perfect working order. Defective guards must be replaced immediately.
- ⚠ Damaged table inserts are to be replaced with new ones.
- ⚠ Regular maintenance and cleaning of bandsaw blades, extraction system, etc. is required to reduce noise.
- ⚠ Refit removed guards in accordance with the manufacturer's instructions.
- ⚠ Never clean the bandsaw blade or bandsaw wheels with a hand-held brush or scraper while the bandsaw blade is in motion.
- ⚠ Do not start cutting until the bandsaw blade has reached full speed.
- ⚠ Do not use damaged bandsaw blades.
- ⚠ Check the bandsaw blades regularly for damage.
- ⚠ Replace damaged bandsaw blades immediately.
- ⚠ Only use bandsaw blades suitable for the operation and the material to be processed.
- ⚠ Do not exceed the permissible speed of the bandsaw blade.
- ⚠ Do not use damaged tools.
- ⚠ Damaged parts must be replaced with new ones.
- ⚠ Repairs may only be carried out by qualified personnel with the main switch locked.

5.2.5 Safety Equipment

The machine is equipped with the following necessary safety devices:

- Complete protection of the saw blade along its entire length.
- The saw blade guard is manually height-adjustable and covers the saw blade from all four sides, preventing hands from entering the danger zone.
- When the doors / guards are opened, the power supply to the motor is automatically interrupted.
- Additional safety switches prevent unintentional opening of the doors. In order to be able to open the doors during a belt or wheel change, the safety switches must first be manually unlocked (see section ⇒ 10.2).
- The bandsaw guide is equipped with a transparent protective cover to ensure a clear view of the cutting area for the operating personnel. At the same time it partly serves as splinter protection.
- The bandsaw maintains the prescribed braking time of < 10 seconds when switched off via the rotary switch (1) resp. the pushbutton (2) - see section ⇒ 9.1 - or when the optional emergency stop is actuated.
- The blade tension indicator shows the correct tension of the blade in relation to its width.
- The machine can be optionally equipped with an emergency stop. An emergency stop is already included in models with an optional push-button or push-switch unit.

5.2.6 Noise

Certain instructions must be followed to avoid an increase in the noise level:

- Sawdust falling between the wheel and the saw blade can cause vibrations that can increase the noise level.
- Only original saw blades with a correct and clean weld must be used.
- The saw blade must be correctly adjusted for the intended work and suitable for the material.
- The instructions for the wheel surfaces (section ⇒ 16.4) and the saw blade (see section ⇒ 16.5) must be followed to keep the parts in good condition and reduce the noise level.

5.3 Danger Zones on the Bandsaw

5.3.1 Danger Zone Bandsaw Blade

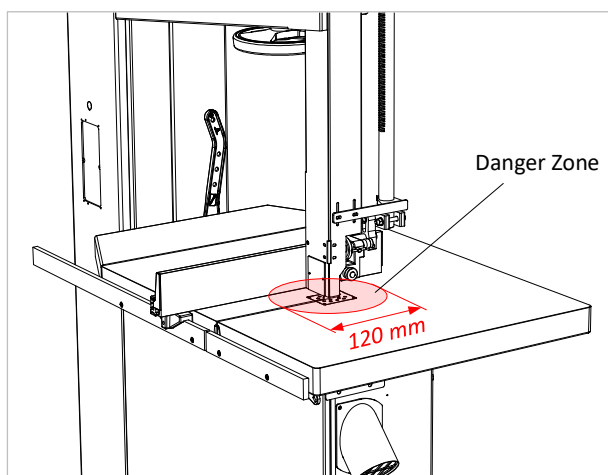

Figure 2: Danger zone saw blade

- The area 120 mm around the saw blade is a danger zone.
- Make sure that your hands are at least 10 cm away from the saw blade.
- If a minimum distance of 10 cm cannot be maintained, use a push stick or other suitable aid for feeding the workpiece.
- When feeding the workpiece, place your hands flat with your thumbs on them and do not spread your fingers.
- Lower the guard to a distance of max. 5 mm from the workpiece.



Danger of cutting and being drawn in! Danger zone of 120 mm around the saw blade!

5.3.2 Danger Zone around the Machine

Another danger zone is located to the right of the machine. Here there is a particular risk of serious injury from a torn bandsaw blade, which can be ejected in this area. During operation, it is strictly forbidden for the operator as well as any helpers and possible observers to stay in this area!

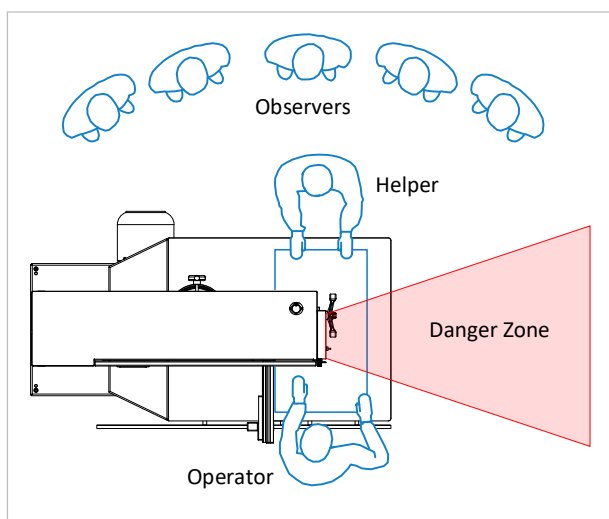

Figure 3: Danger zone around the machine

- The operator of the machine must generally stand in the direction of cutting, in front of the bandsaw and outside the danger zone.
- A required helper for workpiece removal must generally stand opposite the cutting direction and outside the danger zone, behind the machine, on the opposite side to the operator.
- Any observers must stand in a semicircle outside the danger zone. An adequate distance must be kept so that the operator of the machine and a possible helper are not hindered in their work.



Be aware of the danger posed by an ejecting bandsaw blade in the event of a band break! Entering the danger zone during operation can lead to very serious injuries.



Only use bandsaw blades that are in perfect condition resp. have been correctly welded, ground and set. Damaged bandsaw blades must be replaced immediately.

6 Machine Data

6.1 Series and Expandability

Nameplate:

		R. Beck Maschinenbau GmbH Im Grund 23 D-72505 Krauchenwies ☎ +49(0)7576 962978-0 www.beck-maschinenbau.de	
Bandsägemaschine Bandsaw			
Baureihe line	line		
Typ type	type		
Maschinen-Nr. machine no.	machine no.		
Baujahr year of construction	year of construction	202	
Bemessungsspannung U = nominal voltage U =	nominal voltage U =	V	
Frequenz/Phasenzahl frequency/phases	frequency/phases	Hz / 3	
Stromart kind of current	kind of current	AC	
Vollaststrom I = operating current I =	operating current I =	A	
Überstromschutz, extern excess current protection, external	excess current protection, external	A	

Figure 4: Nameplate

<p>Manufacturer: Reinhold Beck Maschinenbau GmbH Im Grund 23 72505 Krauchenwies (Germany) Phone: +49 (0) 7576 / 962 978 - 0 Fax: +49 (0) 7576 / 962 978 - 90 Email: info@beck-maschinenbau.de</p>

Series:

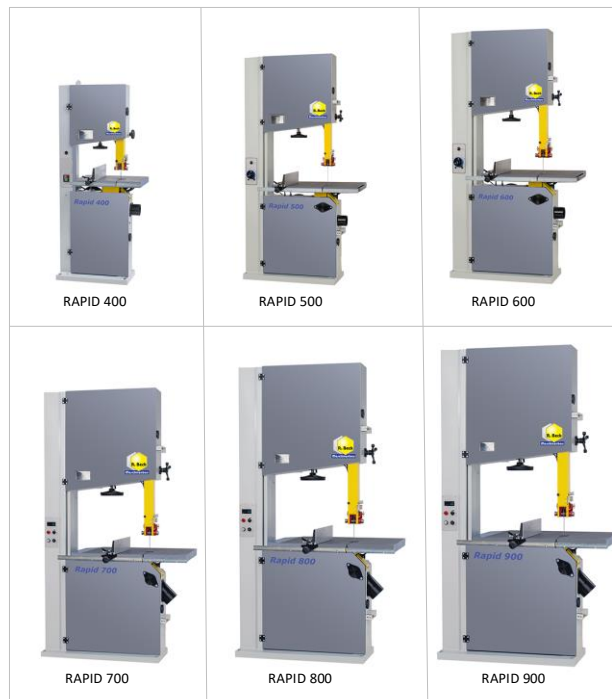

Figure 5: Series RAPID 400 - 900

Expandability:

The machine is designed for the later expansion of optional accessories (see chapter ⇨ 18) from the extensive manufacturer's range. If you wish to expand your machine at a later date, please ask us for documentation on the desired accessories.

Please indicate the following data:

1. **Type**
2. **Machine-No.**
3. **Voltage (V)**
4. **Power (kW)**
5. **Year of manufacture**

6.2 Technical Specifications

Position	Unit	RAPID 400	RAPID 500	RAPID 600	RAPID 700	RAPID 800	RAPID 900
Bandsaw wheels \varnothing	mm	400	500	600	700	800	900
Main motor	kW	1.1	1.5	2.2	3	4	5.5
	HP	1.5	2	3	4	5.5	7.5
Motor brake	-	electrical	electrical ²	mechanical ³	mechanical ³	mechanical ³	mechanical ³
Nominal saw blade speed	m/min	1400	1300	1550	1570	1800	1720
Max. cutting height (GL)	mm	190	325	400	420	500	540
Max. cutting height (APA)	mm	205	330	400	420	520	540
Max. cutting width	mm	385	480	580	680	780	880
Max. saw blade length	mm	3330	4140	4735	5140	5775	6260
Min. saw blade length	mm	3230	4060	4660	5020	5670	6160
Saw blade thickness	mm	0.4	0.4 - 0.5	0.5 - 0.6	0.6 - 0.7	0.7 - 0.8	0.8 - 0.9
Wheel surface width	mm	25	30	30	35	45	47
Max. saw blade width (GL)	mm	20	30	35	35	40	45
Min. saw blade width (GL)	mm	15	15	15	15	15	15
Max. saw blade width (APA)	mm	20	25	30	35	40	40
Min. saw blade width (APA)	mm	15	15	15	15	15	15
Min. blade width with specific crowned wheel	mm	6	6	8	8	10	10
Size saw blade guide	-	1	1	2	2	2	2
Table dimensions	mm	420 x 570	500 x 680	590 x 810	700 x 970	760 x 1140	830 x 1275
Weight	kg	130	220	280	430	550	700

For special applications, the machines can also be supplied with more powerful engines. The nameplate of the machine (see ⇒ Figure 4) shows the motor power (kW / hp), the voltage (V), the current consumption (A) and the frequency (Hz). If you have any questions, please contact our customer service.

6.3 Dimensions

Height x length x width x table height in mm:

RAPID	H	L	W	T
400	1740	760	490	900
500	1930	930	550	900
600	2120	1130	640	920
700	2275	1260	700	920
800	2475	1450	900	930
900	2650	1590	1010	1015

Dimensions and construction subject to change

Space requirement:

The effective space requirement usually depends on the dimensions of the machine and the dimensions of the workpieces to be processed. In general, provide sufficient space around the machine and also calculate the required workplace for the operating personnel and for the infeed and outfeed of the workpieces.

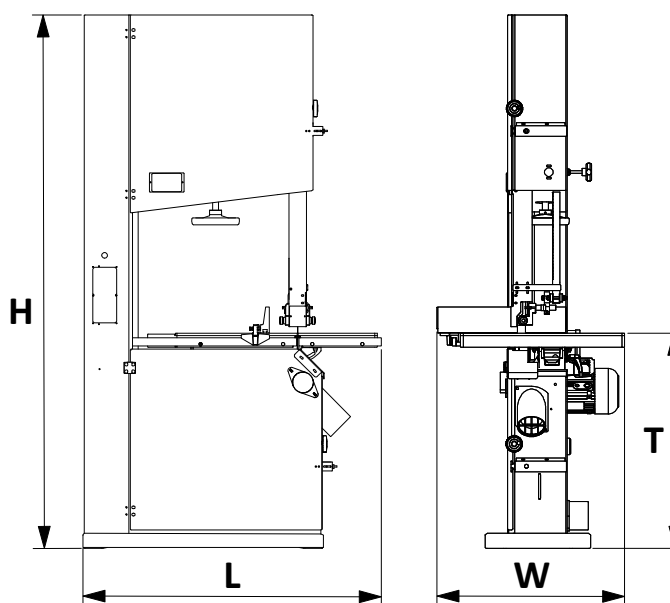

Figure 6: Dimensions

² Mechanical brake on a RAPID 500 model with optional 2.2 kW motor.

³ Electric, wear-free brake with option "Variable Bandsaw Speed Control".

6.4 Emission Levels according to EN ISO 3746:2010

6.4.1 Noise Information

The values given are emission levels and therefore do not necessarily represent safe workplace values. Although there is a correlation between emission and immission levels, it cannot be reliably deduced whether additional precautionary measures are necessary or not.

Factors that may affect the current immission level at the workplace include the duration of exposure, the nature of the workspace, other noise sources, etc., e.g. the number of machines and other activities in the vicinity. The permissible workplace values can also vary from country to country.

However, this information should enable the user to make a better assessment of hazard and risk.

6.4.2 Noise Emission Values

<i>RAPID Version</i>		<i>400</i>	<i>500</i>	<i>600</i>	<i>700</i>	<i>800</i>	<i>900</i>
Noise level							
Idle	dB(A)	80	80	80	85	85	85
Working	dB(A)	102	102	102	97	97	97
Emission pressure level at the workplace							
Idle	dB(A)	67	67	67	68	68	68
Working	dB(A)	89	89	89	89	89	89

Note: When checking the accuracy of the specified emission values, the measurements must be carried out using the same measurement method and the same operating conditions as those specified.

Uncertainty allowance **K = 4 dB(A)**.

	<i>The workplace-related noise emission values of the machine exceed 85 dB(A)! Therefore, suitable hearing protection must be provided to the personnel!</i>
---	---

Note: Regular maintenance and cleaning of the bandsaw blade and extraction system as well as lubrication of the bandsaw blade guides (back and side rollers, see section ⇒ 16.2) generally has a positive effect on the machine's noise level

6.4.3 Dust Emission according to GS-HO-05 in mg/m³ air (permissible max. 2.0 mg/m³ air)

<i>Bandsaw Model</i>	<i>RAPID 400</i>	<i>RAPID 500</i>	<i>RAPID 600</i>	<i>RAPID 700</i>	<i>RAPID 800</i>	<i>RAPID 900</i>
At the workplace	0.23	0.44	0.74	0.39	0.90	0.75

6.4.4 Extraction

<i>Bandsaw Model</i>	<i>Unit</i>	<i>RAPID 400</i>	<i>RAPID 500</i>	<i>RAPID 600</i>	<i>RAPID 700</i>	<i>RAPID 800</i>	<i>RAPID 900</i>
Number of suction nozzles	pcs.	2	2	2	2	2	2
Suction nozzle \varnothing	mm	100	100	100	120	120	120
Stat. negative pressure top/bottom	Pa	800 / 700	720 / 680	640 / 620	390 / 270	390 / 270	390 / 270
Volume flow	m ³ /h	790	790	790	1140	1140	1140

To ensure that the chips extracted at the point of origin and the dust are transported on to the collection system, the conveying speed of the extracted air must be 20 m/s for dry chips and 28 m/s for moist chips (moisture 18% or more).

7 Installation and Connection

7.1 Check Delivery Conditions

Check the consignment for completeness and possible transport damage. In case of transport damage, please keep the packaging and inform the shipping company and the manufacturer immediately! Later complaints cannot be accepted.

7.2 Transport to the Installation Site

7.2.1 Transport of Models RAPID 400 - 700

- The machine is delivered upright bolted on a transport pallet.
- The centre of gravity of the machine is approx. in the middle of the pallet.
- Move between the pallet with a lift truck (see ⇒ Figure 7) and lift the machine only a few centimetres and move it to the installation site.
- Then remove the transport timbers, transport bolts and the lashing eye attached to the machine column.
- Now remove the machine from the pallet with a crane or similar suitable lifting equipment and place it at the place of use.
- Then follow the instructions in section ⇒ 7.4.

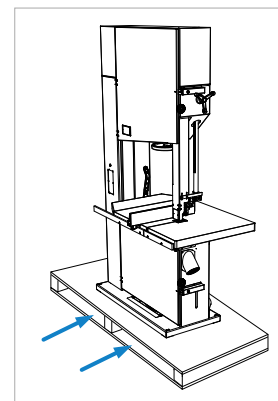
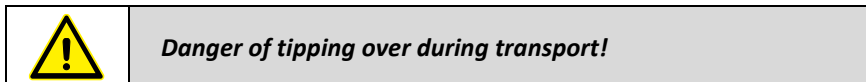

Figure 7: Transport



7.2.2 Transport of Models RAPID 800 - 900

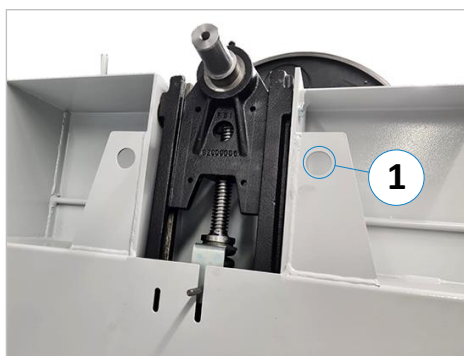

Figure 8: Crane eyelet

- The machine is delivered lying on a transport pallet. First remove the transport timbers, transport bolts and the lashing eye attached to the machine base or the machine column (depending on the model).
- Then it must be lifted from the pallet via the eyelet (1) with the aid of a crane or a similar suitable lifting equipment and erected vertically.
- Now it can be placed on a lift truck with the crane and moved to the installation site.
- Then follow the instructions in section ⇒ 7.4.

7.3 Pre-Assembly

7.3.1 Pre-Assembly of Models RAPID 400 - 700

The bandsaw models **RAPID 400** - **RAPID 700** are delivered completely assembled. Pre-assembly is not necessary.

7.3.2 Pre-Assembly of Models RAPID 800 and 900

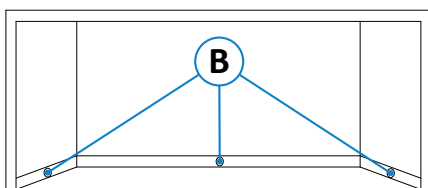
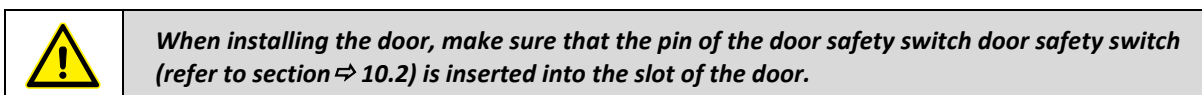

Figure 9: Attach protective cover





- For the models **RAPID 800** and **RAPID 900**, the upper protective cover must still be fitted and fastened via the holes (B) with the three screws supplied.
- In addition, the upper door must be inserted into the hinges and secured with the locking screw above the lower hinge.

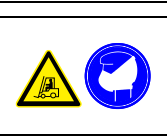

7.4 Installing the Machine

The machine must be placed level on the floor. To do this, level the machine with a spirit level using the 4 grub screws in the machine base. There are four additional holes at the bottom of the machine base, which can be used to secure the machine against tipping with screws. However, these locking screws must not be tightened, as otherwise the machine may be damaged by vibrations occurring.

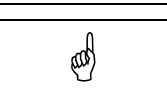
- A foundation is not required. The floor must have a load-bearing capacity corresponding to the machine weight (see “Technical Specifications” in section ⇒ 6.2).
- The bare parts of the machine are greased to protect them from corrosion. Carefully degrease the parts protected against rust with petroleum or benzine.

	<p><i>Be aware of possible crushing hazards when placing the machine (from the pallet to the floor) by means of a forklift truck or overhead crane. Pay particular attention to your hands and feet and wear safety shoes and protective gloves as a precaution.</i></p>
	<p><i>Danger to life when using a forklift truck! Keep a sufficient distance from the forklift truck and watch its speed. Vehicles with combustion engines also produce toxic exhaust gases. Wear a breathing mask if necessary.</i></p>
	<p><i>It is essential that the machine is level! Check with spirit level!</i></p>
	<p><i>Dispose of the packaging material in an environmentally friendly way!</i></p>
	<p><i>Do not use nitro thinner for cleaning. Painted surfaces of the machine can be damaged.</i></p>
	<p><i>Fire hazard! Do not smoke and do not light an open fire.</i></p>

7.5 Temporary Storage

If the machine is not put into operation immediately after delivery, it must be stored carefully in a protected place. Carefully cover the entire machine so that neither dust nor moisture can penetrate. The bare, non-surface-treated parts (e.g. the cast iron tabletop) are provided with a preservative. This must be checked regularly for effectiveness and renewed if necessary.

7.6 Lashing on a Transport Vehicle

The responsibility for safe loading is borne by the respective shipper!

	<p><i>A <u>separate lashing strap</u> must be used for <u>each</u> lashing point. Every lashing point must be tensioned individually on the loading area of the vehicle! The pallet must also be secured against slipping!</i></p>
---	---

Please note the following when lashing in the transport vehicle:

- The loading area of the transport vehicle must always be clean and dry.
- The lashing straps used must be suitable for the total weight of the machine (see section ⇒ 6.2).
- Fastening on the loading area is done by lashing down: This means that the transport pallet is secured by frictional locking. The load is pressed so firmly onto the loading surface that it can no longer slip. The clamping tool should have a high STF value at the frictional connection, e.g. long-lever ratchets.
- In addition, anti-slip mats should be used to provide even more safety.
- The ideal lashing angle (α) for tie-down lashing is 83° to and 90°. Therefore, the lashing straps should pull downwards approx. vertically. As the angle decreases, the pretensioning force of the lashing is reduced.
- Observe the permissible total weight of the transport vehicle.
- Ensure that the permissible axle loads of the transport vehicle are observed. The load must be distributed evenly on all axles of the vehicle.

7.6.1 Lashing Models RAPID 400 / 500 / 600

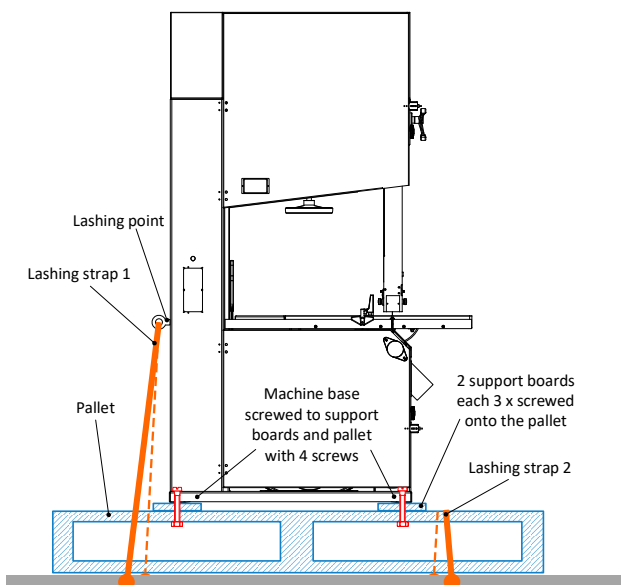

Figure 10: Lashing models RAPID 400 / 500 / 600

- For transport in a transport vehicle, the machine must be bolted upright on a pallet and braced with 2 lashing straps on the loading area.
- For this, there is a lashing point for lashing strap 1 on the left machine column (see ⇒ Figure 10). The pallet is directly lashed with lashing strap 2.
- Screw two support boards between the pallet and the machine base to the pallet with at least 3 screws⁴ each.
- The machine must then be screwed⁴ to the support boards and the pallet via the 4 holes in the machine base.
- An anti-slip mat between pallet and loading area of the vehicle provides additional safety.
- Additionally secure the machine against tipping over!

7.6.2 Lashing Models RAPID 700 / 800 / 900

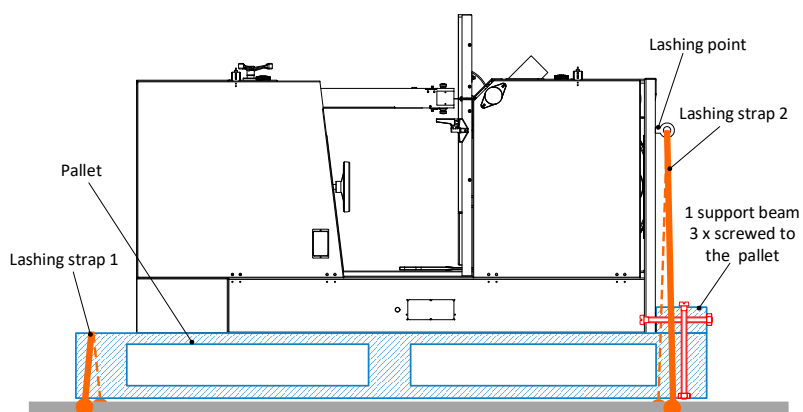

Figure 11: Lashing models RAPID 700 / 800 / 900

- The machine must now be attached to the support beam with 2 screws⁴ via the 2 holes in the machine base.
- An anti-slip mat between pallet and loading area of the vehicle provides additional safety.
- Additionally secure the machine against tipping over!

- For transport in a vehicle, the machine must be screwed to a pallet in a lying position and braced on the loading area with 2 lashing straps.
- There is a lashing point for lashing strap 1 (⇒ Figure 11) under the machine base. The pallet is directly lashed with lashing strap 2.
- On this side, fix a support beam to the pallet with at least 3 screws⁴.

⁴ Generally use sturdy screws of sufficient length and diameter to match the hole! Hexagonal screws with matching nuts and large washers on both sides are best suited.

7.7 Connecting the Extraction Unit

- The machine must be connected to an effective extraction system on-site.
- You will find the diameter of the suction nozzles (A) of your machine in the technical specifications (⇒ 6.2).
- All parts of the extraction system, including hoses, must be included in the earthing measure.

	When flexible suction hoses are used, they must be flame-retardant.
---	--

	When the machine is switched on, the extraction system must start automatically.
---	---

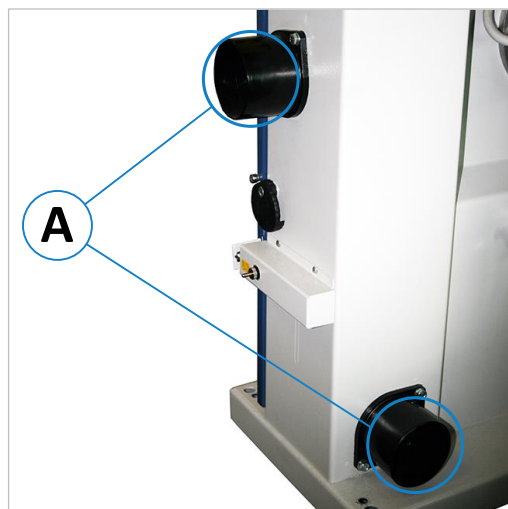

Figure 12: Suction nozzles

On most models, 2 signal generator lines can be connected to the terminals of the contactor for automatic switching of the extraction system:

Model	Contactor Terminal	Model	Contactor Terminal
RAPID 400	unavailable	RAPID 700	163 + 164 of contactor K1
RAPID 500*	1 + 2 of rotary cam switch S2	RAPID 800	163 + 164 of contactor K1
RAPID 600	1 + 2 of rotary cam switch S2	RAPID 900	163 + 164 of contactor K1

*) only available with optional 2.2 kW motor

Installation only by a qualified electrician!

The air speed must be set in such a way that, with the extraction line connected and the tools stationary, an average air speed of

- 20 m/s (1450 m³/h) for dry chips,
- 28 m/s (2050 m³/h) with moist chips (moisture 18 % or more)

is achieved at the extraction nozzles.

The required air volume for extraction is 1000 m³/h.

If the machine is properly connected to the extraction system, it can be assumed that the wood dust assessment value will be complied with (permanently and safely).

	<ul style="list-style-type: none"> • The air velocity must be checked before initial commissioning and after significant changes. • The extraction system must be checked daily for obvious defects after initial commissioning and monthly for effectiveness.
---	--

At certain intervals (or depending on the frequency of use) it is necessary to clean the inside of the machine from sawdust. When operating in closed rooms, an external chip and dust extraction system must be connected.

7.8 Electrical Connections

	The connection must be carried out by an authorised electrician!
---	---

The circuit diagrams are located behind the main control panel or (optionally) in the control cabinet.

Please observe the specified nominal voltage 400 VAC / 50 Hz (3 phases / N / PE)!

- Ensure that the motor voltage (as indicated on the motor plate) matches the mains voltage.
- The supply cable is inserted through the cable gland at the bottom of the terminal box.
- The connection to the mains (3 phases) is made at the terminal strip in the terminal box or optionally in the control cabinet. The 3 phases must be connected to the terminals “L1”, “L2”, and “L3”.
- The protective earth wire (yellow/green) must be connected to the terminal marked “PE”.
- Then close the cable gland again so that it is dust-tight.



Figure 13: Control cabinet (option)

The wire cross-section as well as the back-up fuse depend on the bandsaw model and the motor power:



Figure 14: Connections

Motor Power	Fuse	Cross-section mm ²
1.1 KW	16 A	The wire cross section must be determined on site by a qualified electrician!
1.5 KW	16 A	
2.2 KW	16 A	
3.0 KW	16 A	
4.0 KW	20 A	
5.5 KW	20 A	
7.5 KW	25 A	

Note: Some models are equipped with additional fuses in the control panel. These protect against a possible brake short-circuit or the optional laser cut position indicator.

Fuses used for this: 1 A (time-lag) each.

Important:

Also check the correct running direction of the bandsaw blade. If the running direction is incorrect, two phases in the control cabinet must be reversed.

	The fault loop impedance and the suitability of the overcurrent protection device must be checked at the installation site of the machine.
---	---

The electrical wiring and connection must be carried out by a specialist in accordance with the applicable local EVU, VDE and EN regulations.

Please note:

Only if the connection is carried out by an authorised electrician can a guarantee be given for the motor. In the event of a complaint, the electrician must confirm in writing that he has connected the machine in accordance with the regulations.

8 Components and Controls

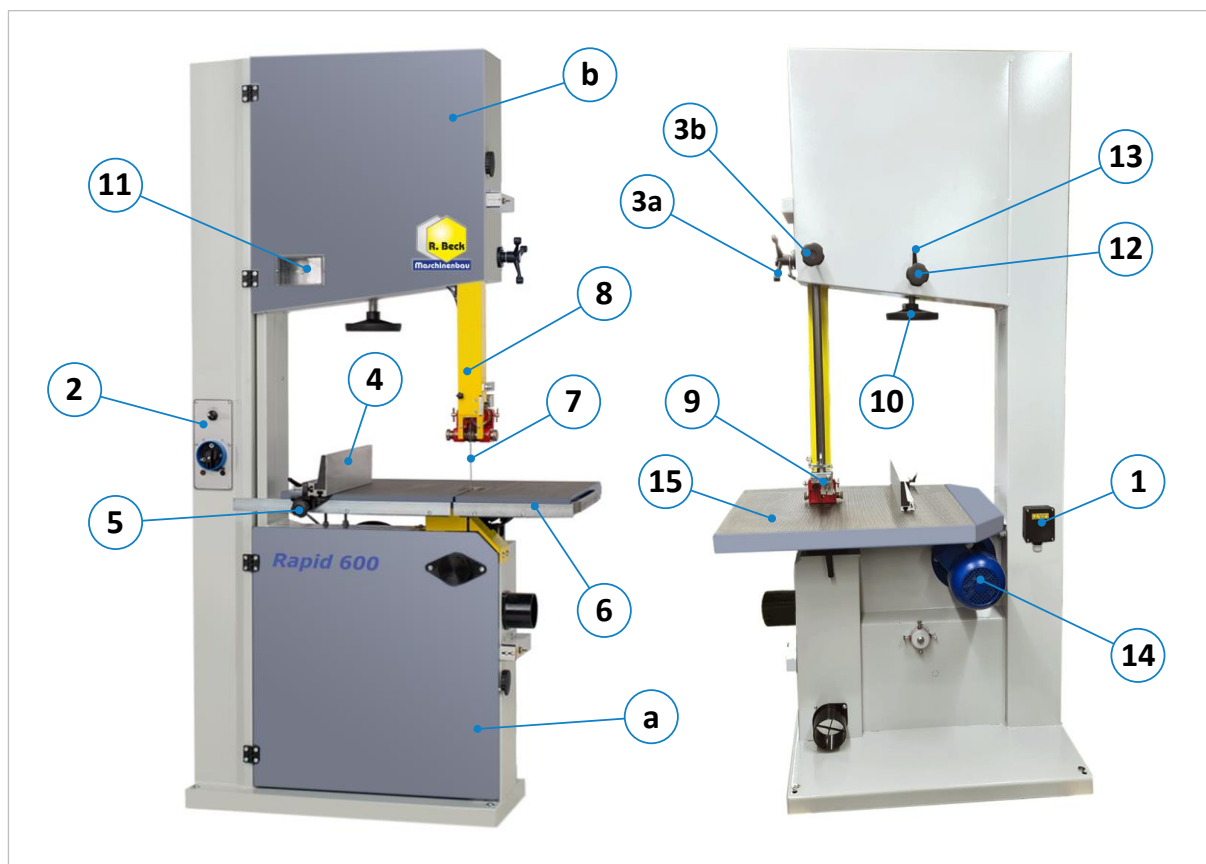



Figure 15: Components and controls

Pos.	Description	Pos.	Description
1	Terminal box (control cabinet optionally)	9	APA bandsaw guide
2	Control panel and emergency stop ⁵	10	Adjusting wheel for saw blade tension
3a	Height adjustment lever for upper saw blade guide	11	Indicator for saw blade tension
3b	Clamping wheel for height adjustment lever (3a)	12	Wheel for upper wheel inclination
4	Rip fence	13	Clamping lever for adjusting wheel (12)
5	Rip fence clamping	14	Main motor
6	Rip fence guide	15	Machine table with table insert
7	Bandsaw blade	a	Cover for drive wheel (bottom)
8	Saw blade guard	b	Cover for upper wheel

⁵ An additional emergency stop switch is available as an option under Art. No. 5210 (see chapter ⇒ 18).
For models with push-button or push-switch panel, the emergency stop is integrated in the control panel.

9 Commissioning

Read the operating manual and the chapter ⇒ 5 “Safety” carefully before commissioning and observe them.

	<p>Before switching on, check that</p> <ul style="list-style-type: none"> • the floor around the machine is clean and free of interfering parts and workpieces, • there are no loose parts on the machine table and all tools have been removed, • the bandsaw blade is well ground and correctly positioned on the guide rollers, • there are no objects in the bandsaw wheels, • the safety guards are fitted according to regulations, • the extraction system is connected and in good working order, • the saw blade tension is correctly adjusted, • the V-belts are tensioned • and no persons are in a danger zone of the machine.
---	--

9.1 Switching ON and OFF

9.1.1 Switch on 2.2 kW Models

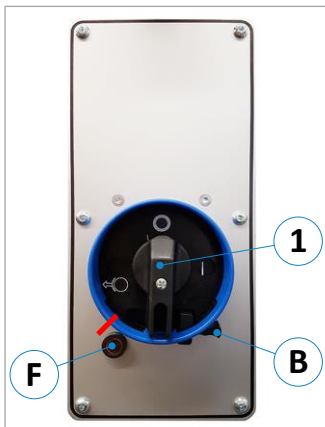

Figure 16: Machine switch (2.2 kW)

- Check saw blade tension (tighten if necessary).
- Make sure that there are no objects on the machine, the doors are closed and the safety switches (refer to section ⇒ 10.2) are locked.

Switching ON:

- Turn rotary switch (1) to position “I”.

Switching OFF:

- Turn rotary switch (1) to position “O”
→ Machine is braked.

Release the brake:

- Turn rotary switch (1) to position “O”.
- Turn the locking latch (B) to the left (see red marked position in ⇒ Figure 16).
- Turn the rotary switch (1) all the way to the left
→ Brake is released (dwell time = 10 s).

9.1.2 Switch on 3.0 - 7.5 kW Models



Figure 17: Machine switch (3.0 - 7.5 kW)

- Check saw blade tension (tighten if necessary).
- Make sure that there are no objects on the machine, the doors are closed and the safety switches (refer to section ⇒ 10.2) are locked.

Switching ON:

- Turn the rotary switch (1) to the “START” position and hold it there until full speed is reached.
- Release the switch (jumps back to position “I”).

Switching OFF:

- Turn rotary switch (1) to position “O”.
→ Machine is braked.

Release the brake:

- Turn rotary switch (1) to position “I”
→ Brake is released (dwell time = 10 s).

9.1.2.1 3.0 - 7.5 kW Models with Push-Switch Unit (Option)



Figure 18: Push-switch unit (3.0 - 3.5 kW)

- Check saw blade tension (tighten if necessary).
- Make sure that there are no objects on the machine, the doors are closed and the safety switches (refer to section ⇨ 10.2) are locked.
- Make sure that the brake release switch (3) is turned to the left position (“inactive”).
- Turn the main switch on (position “I”).
Remark: The main switch is in the control cabinet.

Switching ON:

- Press switch (1) and wait until the bandsaw has reached its full speed.

Switching OFF:

- Press switch (2) → Machine is braked.
- To disconnect the machine from the power supply, turn off the main switch (position “O”).

Release the brake:

- Turn main switch (1) to position “I”.
- Turn brake release switch (3) to the right (“active”) → Brake releases / control lamp (3) lights up.

9.1.3 Switch on Machines with Electric Brake

9.1.3.1 1.1 - 1,5 kW Models with Push-Button Unit



Figure 19: Push-button unit (1.1 - 1.5 kW)

- Check saw blade tension (tighten if necessary).
- Make sure that there are no objects on the machine, the doors are closed and the safety switches (refer to section ⇨ 10.2) are locked.

Switching ON:

- Press button (1) and wait until the bandsaw has reached its full speed.

Switching OFF:

- Press button (2) → Machine is braked.

9.1.3.2 1.5 – 2.2 kW Models with Push-Switch Unit (Option)



Figure 20: Push-switch unit (1.5 - 2.2 kW)

- Check saw blade tension (tighten if necessary).
- Make sure that there are no objects on the machine, the doors are closed and the safety switches (refer to section ⇨ 10.2) are locked.
- Make sure that the “Ready” control lamp (4) lights (doors closed / brake ok / emergency stop unlocked).

Switching ON:

- Press switch (1) and wait until the bandsaw has reached its full speed.

Switching OFF:

- Press switch (2) → Machine is braked.

9.1.4 Switching on with Variable Saw Blade Speed Control (Option)

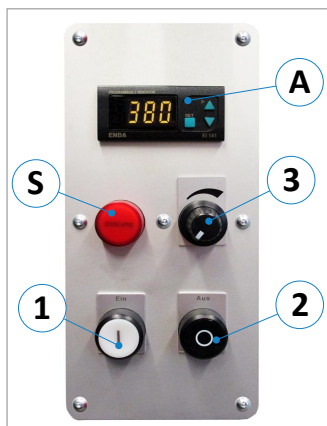

Figure 21: Panel with variable speed control

- Check saw blade tension (tighten if necessary).
- Make sure that there are no objects on the machine, the doors are closed and the safety switches (refer to section ⇒ 10.2) are locked.
- Turn the main switch on (position "I").

Remark: The main switch is in the control cabinet.

Switching ON:

- Press switch (1) and wait until the bandsaw has reached its full speed.
- The speed can be adjusted infinitely by means of a potentiometer (3) and read off from the display (A).

Switching OFF:

- Press switch (2) → Machine is braked.
- To disconnect the machine from the power supply, switch off the main switch (position "O").

Note: The control lamp (S) "Fault" lights up in the event of a fault on the frequency inverter. If this occurs, please contact our customer service.



Danger from electric shock at the frequency inverter! After switching off the main switch wait at least 15 minutes before working on the unit!

For more information on this option, refer to the section ⇒ 14.2.

9.2 Frequent switching ON and OFF in succession

Avoid switching on and off several times in quick succession, as a bandsaw machine is not designed to be switched on and off constantly. This may cause an overload, which will trip the fuses or the motor protection device. In addition, on larger models with mechanical motor brakes and high flywheel mass, frequent switching on and off can cause damage to the motor brake. The mechanical motor brakes of the bandsaws are designed for a maximum of 10 braking cycles per hour.



Switching on and off several times in short intervals can cause damage to the machine and/or the motor brake.

10 Settings and Operation

10.1 Basic Factory Setting

The machine is precisely adjusted and extensively tested before delivery. The bandsaw wheels are adjusted at the factory using the adjustment points (J) provided on the machine, see ⇒ Figure on the right.

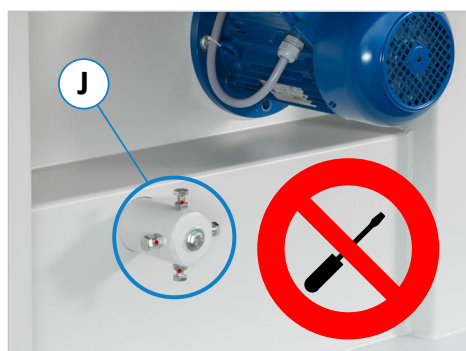
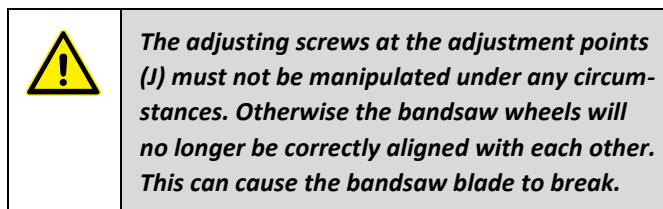

Figure 22: Factory adjustment points

Adjustment of the adjustment points (J) is reserved exclusively for Reinhold Beck Maschinenbau GmbH factory technicians! In case of doubt or problems with the machine, please contact our customer service department.

Note: The adjustment screws are also protected against unauthorised opening with a red lacquer. If the screws are nevertheless adjusted without authorisation, any guarantee for the repair of the resulting damage is invalidated in this respect.

10.2 Door Interlock with Safety Switches

To prevent unintentional door opening during operation and the associated dangers, the machine is equipped with a safety switch on each ⁶ of the two doors.

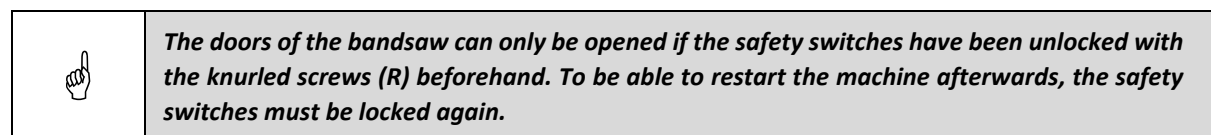

Unlock:

To open the door, the knurled screw (R) on the respective safety switch must be turned fully clockwise ☺ up to the stop so that the threaded pin (G) protrudes completely from the housing of the switch.

→ The door is unlocked and can be opened.

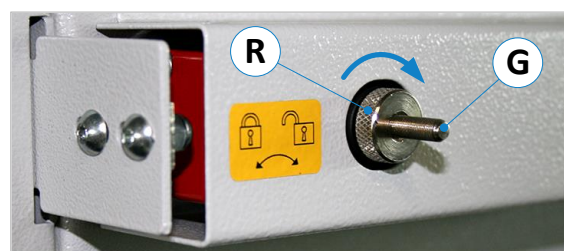

Figure 23: Safety switch - door unlocked

Lock:

After changing the bandsaw blade, the door must be closed and locked again. To do this, turn the knurled screw (R) on the safety switch fully counter-clockwise ☹ until the grub screw (G) disappears completely into the knurled nut again.

→ Only then can the machine be started again.



Figure 24: Safety switch - door locked

⁶ The version RAPID 400 has only one safety switch that secures both doors simultaneously.

10.3 Inserting and Tensioning a Bandsaw Blade

To ensure safe working without incidents, the bandsaw blade must be placed and adjusted properly. For wide blades, at least two persons are required for this purpose.



Caution: Danger of cutting! Put on protective gloves when changing the bandsaw blade!

- Disconnect and secure models without a main switch or turn off and lock the main switch with a padlock.
- Unlock the two safety switches for the doors (a) and (b) according to section ⇨ 10.2.



The doors of the bandsaw can only be opened if the safety switches have been unlocked beforehand with the knurled screws (R), see section ⇨ 10.2. Before the machine can be started again, the safety switches must first be locked.

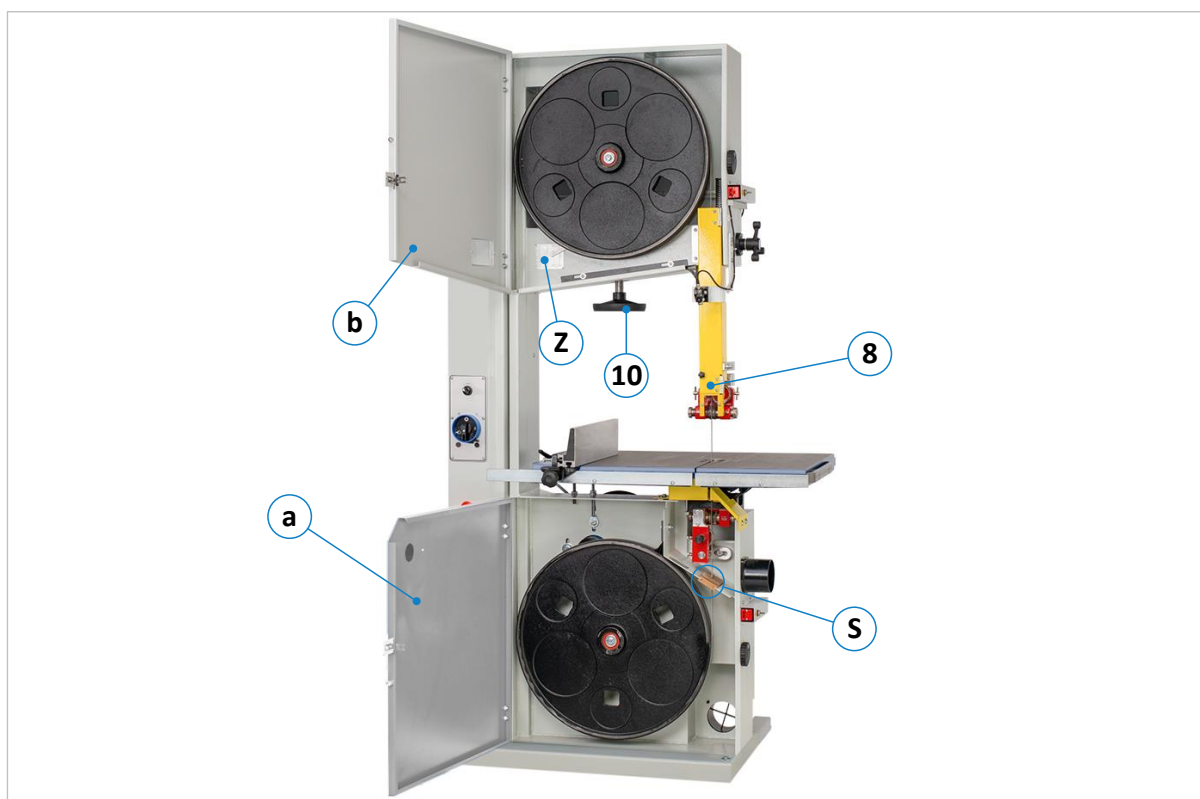

Figure 25: Overview - Inserting and tensioning the bandsaw blade

- Open both doors (a) and (b) and the blade guard (8).
- Remove chip catcher (S) by pulling it out.
- Loosen the handwheel (10) for the band tension and remove the old bandsaw blade if necessary.
- Place the new blade on the wheels (teeth pointing outwards) and pretension slightly via handwheel (10).
- Reconnect the machine to the power supply.
- Only on machines with mechanical motor brake → Turn brake release switch to position “active”.
- Now check by turning manually whether the saw blade runs cleanly and centrally and align if necessary.
- Set the final saw blade tension with the handwheel (10) and the pointer (Z) of the blade tension indicator.



The blade tension is indicated by the pointer (Z). The blade must be tensioned until the pointer points to the line that corresponds to the indicated blade width.

Example 30 mm blade → The pointer (Z) must point to the line belonging to No. 30.

- Push the chip catcher (S) back in and close the blade guard (8).
- Close the doors again, lock the safety switch and switch off the brake release switch if necessary.
- Switch on bandsaw blade and start test run.

10.4 Adjusting the upper Bandsaw Wheel

The wheel adjustment controls are located at the top of the rear of the machine (see ⇨ Figure 26).
By turning the bandsaw wheel by hand, the position of the blade can be checked.

	<i>On machines without an electronic motor brake, the brake release switch must be turned to "active" before turning the bandsaw wheel by hand.</i>
---	--

	<i>Adjustment of the wheel may only be carried out by trained personnel!</i>
---	---

The star knob (12) is used to adjust the inclination of the upper bandsaw wheel. This allows the position of the blade on the bandsaw wheel to be determined. Clamping lever (13) is used to clamp the star knob (12).

The blade must run on the bandsaw wheels as follows:

- **Narrow bandsaw blade** → In the middle of the wheels
- **Wide bandsaw blade** → Teeth at the edge of the wheels, but not protruding beyond them.

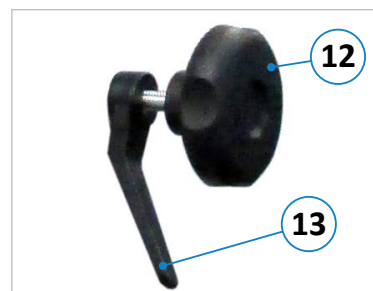



Figure 26: Bandsaw wheel adjustment

10.5 Height adjustment of the upper Saw Blade Guide

	<i>The height should be set for material processing so that the guide rollers of the saw blade guide are a maximum of 4 - 5 mm above the workpiece.</i>
---	--

The height adjustment of the upper saw blade guide (incl. saw blade guard) is done manually via the 3-arm lever⁷ (3a) and the star knob (3b), which is used only for clamping.

Adjust height:

- First loosen the clamp with the star knob (3b).
- Turn the 3-arm lever (3a) to the left ↶ → move upwards.
- Turn the 3-arm lever (3a) to the right ↷ → move downwards.
- After adjustment, clamp again with star knob (3b).

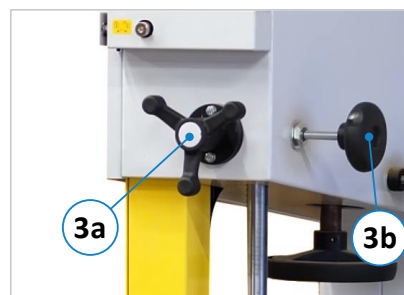

Figure 27: Lever for height adjustment

10.6 Swivel Table

Bandsaws of the RAPID series have a swivelling table plate as standard, which can be tilted up to 45°. Clamping lever and angle scale are located on the rear side of the machine under the table.

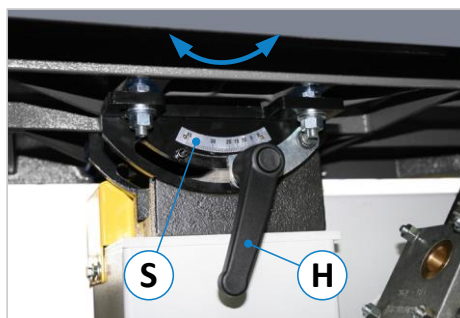

Figure 28: Adjust table inclination

Adjust table inclination:

- Remove workpieces and workpiece-remains from the table.
- Position the fence to the right of the saw blade and fasten it.
- Release the clamping with lever (H).
- Tilt the table to the desired angle by hand.
- The angle can be read off the scale (S).
- Then clamp the table again with the lever (H).

Note: Optionally, a table swivelling device is available, which can be adjusted via a hand crank (for more details see section ⇨ 14.4).

⁷ The model RAPID 400 has a handwheel instead of the 3-arm lever.

10.7 Adjusting the GL Bandsaw Guides

This chapter only describes the adjustment of the standard bandsaw blade guides type “GL”. If your machine is equipped with the optional bandsaw blade guides type “APA”, you will find the corresponding adjustment procedure and all further information in section ⇒ 14.1.

10.7.1 Structure and Components

The adjustment of the two saw blade guides is necessary when starting up the machine as well as when changing the bandsaw blade.

The structure is identical for the upper and lower saw blade guide. The GL saw blade guide consists of the following components:

Pos.	Description	Pos.	Description
B	Support bolt	R	Back roller
K1	Tommy screw 1	S	Side rollers
K2	Tommy screw 2	H	Holder
L	Side bearing sleeve	X	Clamping unit
M	Lock nut		

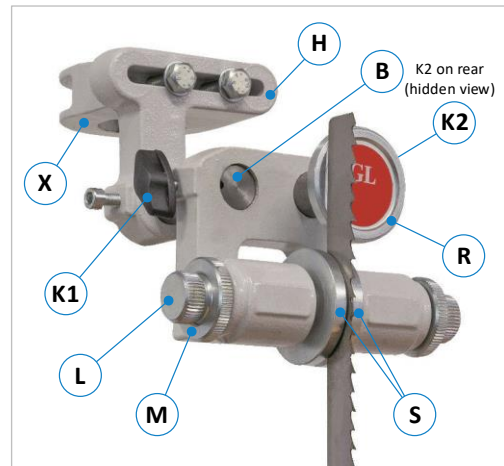

Figure 29: GL 456 - Structure and components

10.7.2 Adjusting the GL Saw Blade Guides

To ensure proper functioning of the bandsaw, the two saw blade guides, each with two side rollers and a back roller, must be correctly adjusted. The two side rollers serve to fix the saw blade laterally in the correct position. The purpose of the back roller is to support the bandsaw blade during cutting against the force and movement of the workpiece feed from behind.

Before adjustment, clean the guides thoroughly and remove dust, dirt and resin deposits. The procedure for adjustment is identical for the upper and lower saw blade guides:

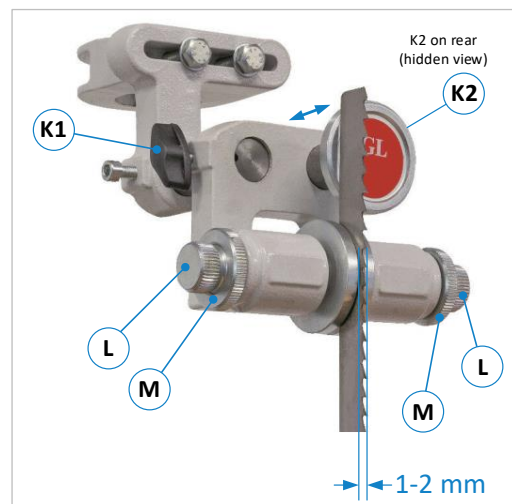

Figure 30: Adjusting the GL saw blade guides

- Loosen the back roller with the tommy screw (**K2**) and move it all the way back.
- Loosen the lock nuts (**M**) of the two side bearing sleeves (**L**).
- Adjust the two side rollers with the side bearing sleeves (**L**) outwards so that a newly placed saw blade can run freely between them.
- Place, tension and align the saw blade (see ⇒ 10.3).
- Loosen the tommy screw (**K1**) and adjust the complete guide on the support bolt (**B**) by moving it so that the front edges of the side rollers are approx. 1 - 2 mm behind the tooth base of the saw blade (see ⇒ Figure 30).
- Place the back roller so close to the back of the saw blade that it is just not touched when the machine is idle.
- The saw blade must not touch the back roller until the cutting pressure is applied during machining.

- Adjust the side rollers so that they only lightly touch the saw blade (see ⇒ Figure 31). Please take care that the saw blade is not pushed to the side!
- After adjustment, tighten the two lock nuts (**M**) and the tommy screws (**K1**) and (**K2**).



**The bandsaw blade guide must not be set too high during machining.
There is a risk of injury from flying chips and a free-running saw blade!**

10.7.3 Basic Setting of the Back and Side Rollers (Overview)

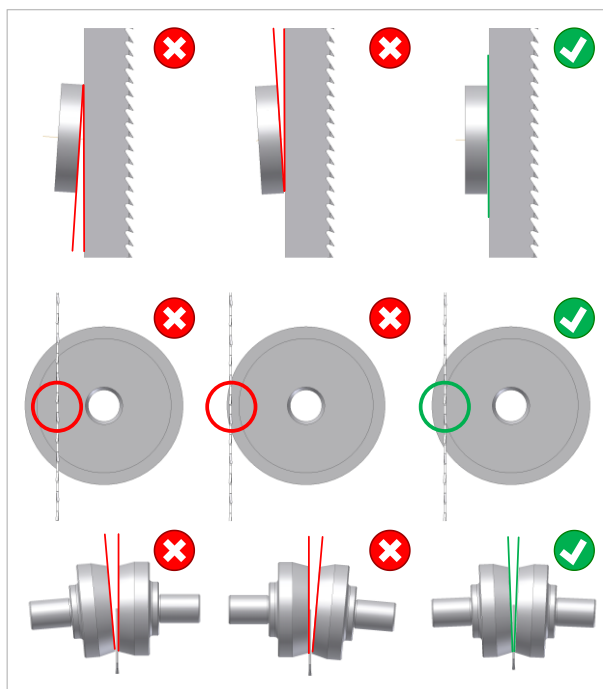

Figure 31: Basic adjustment of the back and side rollers

The two saw blade guides must be aligned with the saw blade as follows:

- The ⇒ Figure 39 shows on the far right the optimal setting of the back and side rollers. On the left and in the middle, it is shown which settings are wrong and must be avoided.
- The back roller must be parallel to the back of the saw blade (vertical), see ⇒ Figure 39 top right.
- The saw blade must run exactly in front of the inner edge of the back rollers (⇒ Figure 39, centre right).
- The side rollers may only touch the saw blade in the front area.
- The opening angles between the side rollers and the saw blade must be the same on both sides (⇒ Figure 39 bottom right).
- Both guides must be exactly vertical.
- After the basic adjustment has been made, tighten the tommy screws (**K1**) and (**K2**) again.

For maintenance and lubrication of the saw blade guides please read the section ⇒ 16.3.

11 Using the Rip Fence

The fence is inserted into the guide rail (F) on the side of the machine table and clamped in the desired position with the clamping wheel (K). The mechanical holding device (V) can be converted in a few easy steps so that the fence is also suitable for left-handers.

The rip fence must always allow to adjust the saw blade guard as low as possible, regardless of the respective workpiece dimensions. This ensures optimum protection for the machine operator.

For this reason, the fence has a higher and a flatter surface. Depending on the workpiece dimensions, the fence can be turned by 90° in order to be able to set the ideal height for the respective workpiece to be machined.

Convert the rip fence from high to flat:

- Loosen the lever (H).
- Pull the stop bar (S) sideways out of the holding device (V).
- Then turn the rail by 90° to the right and reinsert it with the free T-slot (N) back into the holder (V).
- Now tighten the lever (H) again.
- The table stop is now set for flatter workpieces (see ⇒ Figure 33).

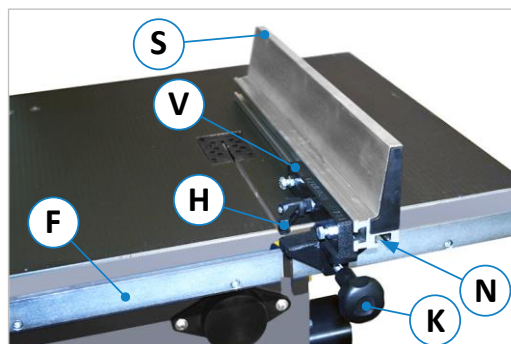

Figure 32: Fence in high position



Figure 33: Fence turned to flat position

11.1 Convert the Fence to the Right of the Saw Blade

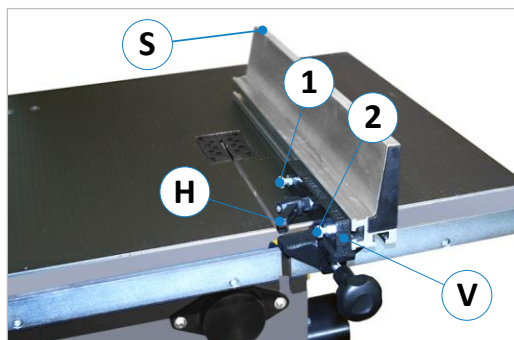

Figure 34: Converting the fence

To be able to use the fence on the right of the saw blade, the following mechanical conversion is required:

- Loosen lever (H) and pull out the fence rail (S).
- Unscrew the lever (H) and the screws (1) and (2) and pull them out of the holes of the holding device (V).
- Now insert the lever and the two screws into the holes from the other side. Then reattach the sliding blocks and tighten the screws (1) and (2) again.
- Turn the rail (S) by 180°, push it back in and clamp it with the lever (H).

12 Replace Table Insert

The table insert reduces the table opening of the bandsaw machine to a minimum and ensures stable guidance of the saw blade due to its narrow incision.

Damaged table inserts must be replaced immediately!

- Please ensure that the incision is as narrow as possible.
- Only use table inserts made of plastic or wood.
- The insert must be at table level and must not protrude above it.



Figure 35: Table insert



Matching table inserts can be ordered in the HOKUBEMA [online shop](#) (including required pin screws). The dimensions vary depending on wheel diameter). **Note:** Due to dimensional tolerances of the cast iron table tops, the table inserts must be individually fitted on site.

13 General Instructions for Use

13.1 Bandsaw Blades

Bandsaw blades must be handled carefully so that they are not damaged. Untensioned bandsaw blades must be folded into a multiple circle without kinks and secured while not in use. They are to be kept stored in a safe and dry area. Always store bandsaw blades on a surface that cannot damage the teeth of the blade. Before use, they must be checked for damaged teeth and cracks.

- To avoid cracking, tensioned bandsaw blades must be kept adequately protected.
- At least two persons are required to change a wide bandsaw blade.
- A suitable transport device is advantageous for transporting tensioned, wide bandsaw blades.
- The saw blade width, tooth shape and tooth pitch must be selected according to the thickness and nature of the workpiece.
- The saw blade must be correctly welded, ground and set. If this is not the case, the saw blade must be renewed (see section ⇒ 16.5).

 	<p>Caution: Danger of cutting! Put on protective gloves when changing the bandsaw blade!</p>
---	---

If these basic rules are not observed, the following problems may occur:

- Poor work result / unclear cut
- Poor performance
- Saw blade cracks

Blade cracks are the most common problems that occur with a bandsaw. They are mostly dependent on the saw blade. They are not caused by the machine, provided it is set according to the operating manual and has not been changed. Chapter ⇒ 15 „Troubleshooting“ lists the main causes and suggestions for preventing saw blade cracks.

13.2 Use of the Machine

	<p>Check blade tension before starting work! Never work with an untensioned saw blade!</p>
---	---

	<p>Be aware of the danger of being drawn into the rotating blade! Wearing protective gloves as well as loose clothing. Long untied hair, wristwatches and jewellery is prohibited when cutting! Always wear close-fitting clothing and a hair net if necessary.</p>
---	--

	<p>Risk of accidents and increased risk of injury! Most accidents happen when the workpieces do not have a firm hold on the machine table. Follow the instructions below!</p>
---	--

Place the adjustable guard on the bandsaw blade as close as possible to the workpiece. The distance between the saw blade guard and the workpiece should not exceed 5 mm when cutting.

	<p>Cutting hazard! Observe the danger zone of 120 mm around the saw blade!</p>
---	---

For **flat workpieces**, use the flat part of the table fence so that the saw blade guard can be lowered to a minimum distance from the workpiece (see chapter ⇒ 10.7).

The workpieces must always rest firmly on the machine table. Round workpieces must be secured against twisting, see Figure (B) on the next page. Do not cut unshapely workpieces that do not lie flat on the table or cannot be secured with one of the aids listed on next page.



Danger of cutting if the workpiece is tilted! The saw blade can tear and cause cutting injuries.

Large and long workpieces

For large or long workpieces, an appropriate table extension must be used, see Figure ⇒ (A). Table extensions are available as an option (see ⇒ 14.6). For cuts without push stick, ensure a safe distance (> 10 cm) of the hands from the saw blade.

Round and cylindrical workpieces

For round and cylindrical workpieces, slipping or rolling away of the workpieces must be prevented. These are to be secured with a handle, wedge, bolt, prism or other comparable tools, see ⇒ Figure (B).

Short pieces - cutting splinters

Always use push sticks to prevent danger to the hands, see ⇒ Figures (C) and (D).

Straight cuts

To prevent the workpiece from tilting or slipping away, always use the fence for straight cuts (see chapter ⇒ 10.7). It must be set to the width of the workpiece to be cut. The workpiece must rest on the table and be fed in a safe way. When feeding manually with the fence, use a push stick if it is necessary to feed close to the bandsaw blade.

Diagonal cuts

On machines with a fixed table, there should be a secure workpiece support for diagonal cutting by means of a fixture. Use a push stick at the end of the cut.

Tenon cutting

If a tenoning machine is not available, tenons can also be cut safely with a bandsaw.

Crosscut sawing of upright standing workpieces

When crosscutting upright workpieces, e.g. when setting down tenons, a possible tilting of the workpiece must be prevented by a stop bracket.

Cutting wedges

To cut small wedges on the bandsaw machine, the use of a fixture is required.

Curved and irregular cuts

When making curved or irregular cuts on a bandsaw, it is necessary to feed the workpiece evenly. It must be held firmly on the table for effective guidance during cutting. The hands must be at a safe distance from the saw blade. A template can also be used. For repeated curved or irregular cuts, a fence fixed in front of the bandsaw blade can be used in conjunction with a template. This improves both safety and working speed.

Cross cutting of round timber

When cross-cutting logs, the workpiece must be secured against rotation by using a fixture or holding device. Further, a bandsaw blade suitable for cross-cutting must be used.

Cutting round plates

A suitable fixture should be used for cutting round panels. We recommend using the optional "Kreisfix" (⇒ 14.8), which is mounted together with the table extension (⇒ 14.6) and which is excellent for circular cuts.

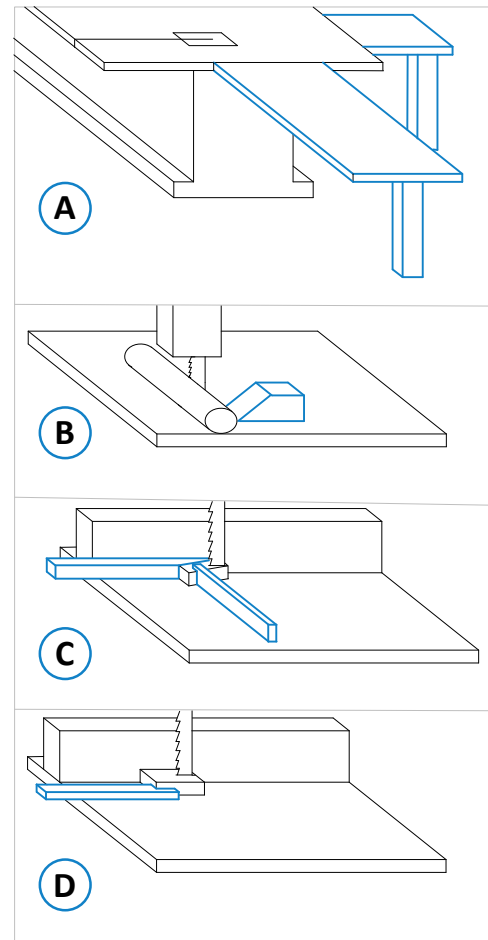

Figure 36: Table extensions and tools

Instruction of the operators

It is essential that all operators are regularly and adequately instructed in the use and adjustment of safety equipment such as guards, pushers, templates and table extensions.

Push devices

The push block including its handle or the push stick must be replaced if damaged.

Generally

- Only use narrow saw blades for curved cutting.
- When feeding the workpiece, place your hands flat on the workpiece, do not spread your fingers.
- Do not pull the workpiece back as this may cause the saw blade to run off the rollers.
- Always feed the workpiece so that the kerf does not close.
- Always feed the lower edge to the saw blade first when cross cutting upright standing workpieces.
- Use auxiliary devices also when machining single pieces.

Furthermore, it should be noted that

- the surfaces of the wheels (especially the lower one) are always free of chips,
- a functioning scraper brush is present,
- the chip catcher is attached to the lower bandsaw wheel and is not damaged,
- blurred or damaged bandsaw blades are replaced immediately,
- dirty workpieces are cleaned of dirt before cutting,
- the distance between the hands and the blade is at least 10 cm,
- and therefore pushing devices are generally used,
- pushing devices do not get into the cutting area,
- the bandsaw blade tension is released during rest periods,
- and the saw blade guard is positioned at table height at the end of work.

13.3 Completion of the Work

When the machine is out of operation, e.g. at the end of a shift, position the saw blade guard all the way down to the level of the table.

Then release the tension on the bandsaw blade and place a corresponding notice on the machine. The cooling of the blade alone, which results in a reduction of the saw blade length, will cause pressure marks on the bandsaw wheel tracks. Furthermore, slight damage to the saw teeth can occur, which can lead to vibrations, etc.

14 Optional Components

The available optional components and accessories vary according to the bandsaw model. Please refer to the tables in chapter ⇒ 18 to see which options and accessories are available for your machine.

14.1 APA 2 - Saw Blade Guides

14.1.1 Structure and Components

The adjustment of the two saw blade guides is necessary when starting up the machine as well as when changing the bandsaw blade.

The structure is identical for the upper and lower saw blade guide. The proven APA 2 saw blade guide consists of the following components:

Pos.	Description	Pos.	Description
B	Support bolt	R	Back roller ⁸
H	Holder	S	Side rollers
K1	Tommy screw 1	V	Sealing plug
K2	Tommy screw 2	X	Rear clamp
L	Side bearing sleeve	Y	Front clamp

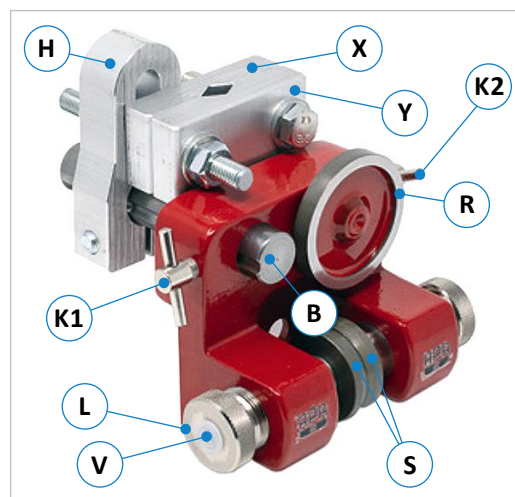

Figure 37: APA - Structure and components

14.1.2 Adjusting the APA Saw Blade Guides

To ensure proper functioning of the bandsaw, the two saw blade guides, each with two side rollers and a back roller, must be correctly adjusted. The two side rollers serve to fix the saw blade laterally in the correct position. The purpose of the back roller is to support the bandsaw blade during cutting against the force and movement of the workpiece feed from behind. Before adjustment, clean the guides thoroughly and remove dust, dirt and resin deposits. The procedure for adjustment is identical for the upper and lower saw blade guides:

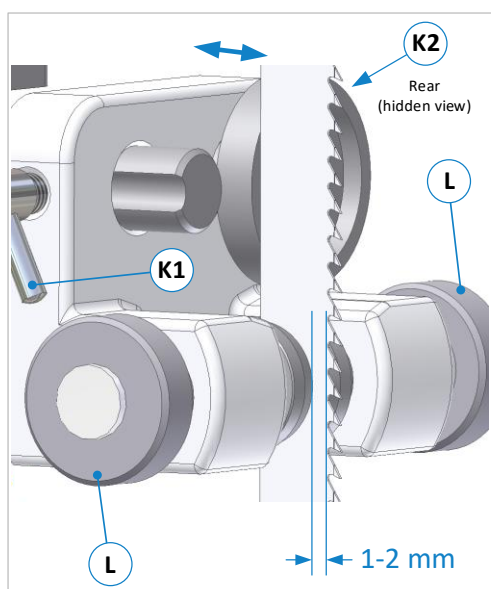

Figure 38: Adjusting the guides

- Loosen the back roller with the tommy screw (**K2**) and move it all the way back by pulling the sealing cap⁸ on the back.
- Adjust the two side rollers with the side bearing sleeves (**L**) outwards so that a newly placed saw blade can run freely between them.
- Place the saw blade, tension and align it (see ⇒ 10.3).
- Loosen the tommy screw (**K1**) and adjust the complete guide on the support bolt (**B**) by moving it so that the front edges of the side rollers are approx. 1 - 2 mm behind the tooth base of the saw blade (see ⇒ Figure 38).
- Place the back roller against the back of the saw blade so that it is not touched when the machine is idling.
- Only the cutting pressure during machining may cause the saw blade to touch the back roller.
- Adjust side rollers so that they only lightly touch the saw blade (see ⇒ Figure 39). Please take care that the saw blade is not pushed to the side!
- After adjustment, tighten tommy screws (**K1**) and (**K2**).



**The bandsaw blade guide must not be set too high during machining.
There is a risk of injury from flying chips and a free-running saw blade!**

⁸ With sealing cap (not visible in picture, as attached on the back)

14.1.3 Basic Setting of the Back and Side Rollers (Overview)

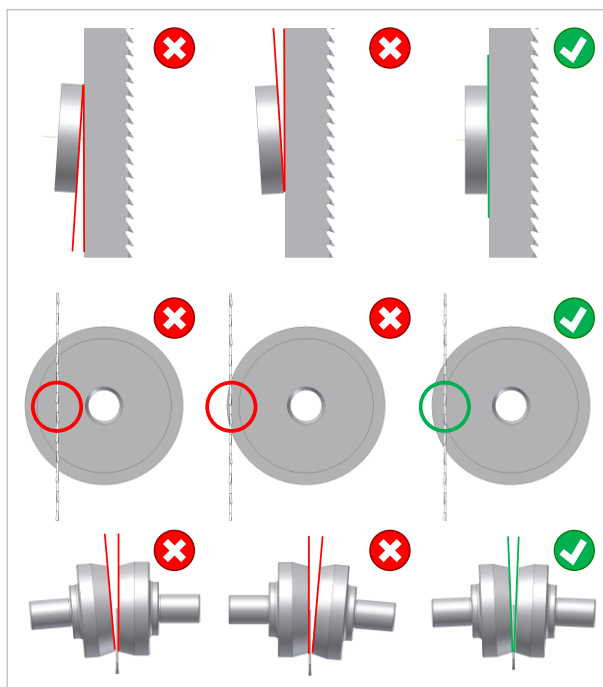

Figure 39: Basic adjustment of the back and side rollers

The two saw blade guides must be aligned with the saw blade as follows:

- The ⇒ Figure 39 shows on the far right the optimal setting of the back and side rollers. On the left and in the middle, it is shown which settings are wrong and must be avoided.
- The back roller must be parallel to the back of the saw blade (vertical), see ⇒ Figure 39 top right.
- The saw blade must run exactly in front of the inner edge of the back rollers (⇒ Figure 39, centre right).
- The side rollers may only touch the saw blade in the front area.
- The opening angles between the side rollers and the saw blade must be the same on both sides (⇒ Figure 39 bottom right).
- Both guides must be exactly vertical.
- After the basic adjustment has been made, tighten the tommy screws (K1) and (K2) again.

14.1.4 Conversion to Left Version

Lower Saw Blade Guide:

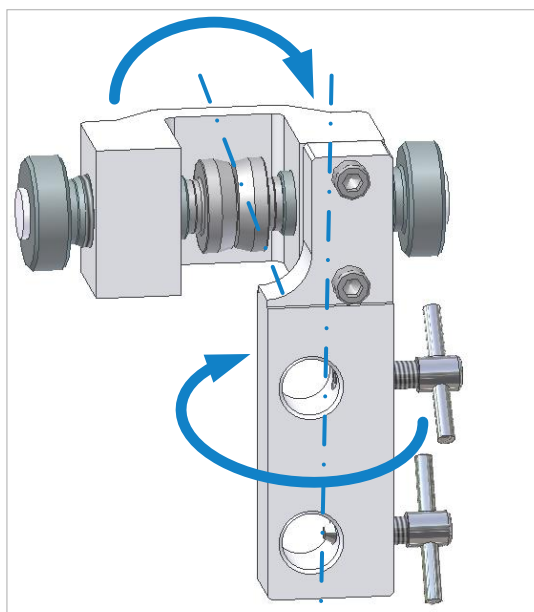

Figure 40: Convert bottom guide to left

- Loosen both tommy screws
- Remove the back roller and the support bolt from the holder.
- Remove the two fastening screws of the support.
- Rotate the holder 180° around its vertical axis.
- Rotate the guide with side rollers 180° around its horizontal axis.
- Screw the holder to the guide again.
- Reinstall the back roller and support bolt and tighten the tommy screws.

Note: For maintenance & lubrication of the blade guides please read the section ⇒ 16.3.

Upper Saw Blade Guide:

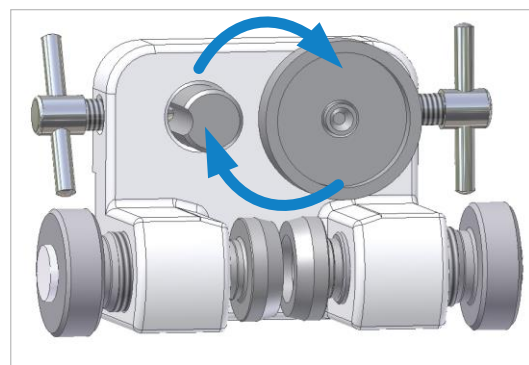

Figure 41: Convert top guide to left

- Loosen both tommy screws
- Swap the support bolt and the back roller
- Tighten the tommy screws again

14.2 Variable Saw Blade Speed Control



Figure 42: Blade speed control

Bandsaws equipped with this option have a special control panel with an additional potentiometer for speed adjustment from approx. 300 to 2000 m/min (varies depending on the model). The actual speed is visualised on a small display in the control panel.

- The potentiometer is used to set the speed
- The speed is visualised in the small digital display
- The red lamp signals faults in the frequency inverter

For further information see section ⇒ 9.1.4.

Art. No. and further accessories see chapter ⇒ 18.

Note: The control lamp “Fault” lights up in the event of a fault on the frequency inverter. If this occurs, please contact our customer service.



Danger from electric shock at the frequency inverter! After switching off the main switch wait at least 15 minutes before working on the unit!

Models with this option are additionally equipped with a wear-free, electric motor brake.

14.3 Measurement Scale on the Table



Figure 43: Measurement scale on the table

The optional measurement scale on the table makes working on the bandsaw easy and simple. The fence can be set exactly to the desired cutting dimension without the need for additional measuring equipment. The scale is firmly integrated in the machine table and its robustness ensures a long service life.

Art. No. and further accessories see chapter ⇒ 18.

14.4 Table Swivel Device

The optional table swivel device is a useful addition, especially for heavy machine tables. Instead of swivelling the table by hand, this option allows to adjust it comfortably and infinitely variable via a hand crank. The adjustment range allows angles up to 45°.

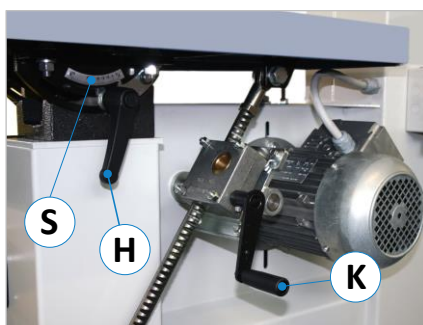

Figure 44: Adjust the table Inclination

Adjust the Table Inclination:

- Remove workpieces and workpiece-remains from the table.
- Place the fence to the right of the saw blade and clamp it.
- Release clamping with lever (H)
- Turn the crank handle (K) and read the angle scale (S) to set the desired position.
- Clamp the table again with the lever (H).

Art. No. and further accessories see chapter ⇒ 18.

14.5 Mitre Fence “Top”

The mitre fence with round rod guide makes work easier when sawing angles and mitres. It can be folded down by 90° so that even flat workpieces (at the prescribed distance of max. 5 mm from the saw blade guard) can be processed safely. The adjustable angle range is $\pm 60^\circ$.

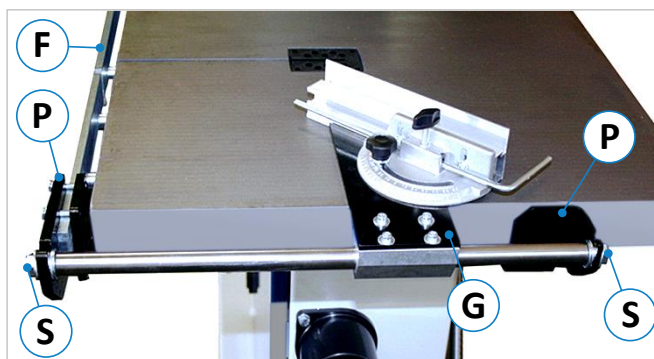

Figure 45: Mitre fence “Top”

Install Mitre Fence:

- The two holding plates (P) are already attached to the rail (F) and the table in the factory⁹.
- Insert the mitre fence (G) with round rod from above into the two black holding plates (P).
- To clamp the fence, tighten the two screws (S).

Art. No. and further accessories see chapter \Rightarrow 18.

14.6 Mitre Fence “Basic”



Figure 46: Mitre fence “Basic”

On machine tables with integrated T-slot, this mitre fence can quickly be installed via the existing guide rail. The adjustable angle range is $\pm 60^\circ$.

Note:

This mitre fence can only be mounted if the option " T-Slot in the Machine Table" is available (the corresponding Article No. can be found under "Options and Accessories" in chapter \Rightarrow 18).

14.7 Table Extension



Figure 47: Table extension

The optional table extension (including mounting rails) replaces an assistant and provides valuable support when machining large and long workpieces. It is easy to move, quick to remove and can be quickly mounted to the mounting rail via a clamping lever. The base is foldable and locks automatically, which ensures a small space requirement when folded.

Art. No. and further accessories see chapter \Rightarrow 18.

14.8 Kreisfix for Circular Cuts



Figure 48: Kreisfix for circular cuts

The Kreisfix is a practical aid for sawing circular workpieces. It enables precise sawing of round arcs and discs, without the need for scribing.

A prerequisite for correct mounting is that the machine is equipped with the table extension (see section \Rightarrow 14.6). When machining workpieces with large diameters, it is recommended to use a second table extension.

Art. No. and further accessories see chapter \Rightarrow 18.

⁹ For later retrofitting, the retaining plates (P) must be attached to the rail and table by the customer.

14.9 Machine Moving Trolley



With the optional mobile trolley, you can make your bandsaw mobile and are no longer tied to a stationary installation site. This allows you to move your machine quickly and conveniently to any desired location in your workshop or joinery.

The trolley for easy transport consists of two swivel castors with brakes and two fixed castors.

Art. No. and further accessories see chapter ⇨ 18.

Figure 49: Machine moving trolley

Note: This option is not available for the bandsaw model RAPID 900.

14.10 Emergency Stop Switch

The RAPID bandsaws can be optionally (see chapter ⇨ 18) equipped with an emergency stop (impact button). An emergency stop is already included in machines with optional push-button or push-switch unit.

14.11 Laser Cut Position Indicator (Option for RAPID 600 - 900)

As an option, the bandsaw models RAPID 600 to RAPID 900 can be equipped with a laser cut position indicator (laser class 1M). This provides optical support during cutting by projecting the cutting edge onto the workpiece. The workpiece can thus be optimally aligned before cutting in order to keep waste as low as possible.



Figure 50: Laser device



Figure 51: Laser cutting edge

Seen from the direction of the workplace, the laser device is installed behind the saw blade guard and tilted in the direction of the machine.

The laser beam projects the exact cutting edge onto the workpiece and thus provides valuable support during cutting.

14.11.1 Special Features of Use

- The installed laser must not be replaced by a laser of a different type.
- No additional optical devices may be used.
- Laser repairs may only be carried out by the laser manufacturer or by authorised persons.

	Caution: Looking directly into the laser beam will cause serious eye injury!
---	---

	The operating instructions of the laser manufacturer must be observed.
---	---

The Art. No. for the laser directional light as well as other accessories can be found in chapter ⇨ 18.

15 Troubleshooting

Proceed systematically when searching for the cause of a malfunction. If you are unable to find the fault or to remedy the malfunction, contact our customer service department (phone number: 0049 7576 / 962 978 - 0).

Before you call us, please follow these steps:

- Make a note of the type, machine number and year of production (see nameplate).
- Keep this operating manual (and any circuit diagrams) to hand.
- Describe the fault to us in detail so that a competent remedy can be found.

15.1 Machine - Troubleshooting

Fault	Possible Cause	Remedy
Bandsaw does not start	No voltage	→ Check connections
	Control fuse defective	→ Replace fuse
	Main switch defective	→ Replace main switch
	Motor defective	→ Replace motor
	Broken V-belt	→ Replace V-belt
	Brake release switch is activated	→ Switch off
	Doors not closed	→ Close the doors
	Door safety switch not locked	→ Lock safety switches (⇒ 10.2)
Motor becomes very hot	Overload or defective motor	→ Contact customer service
Brake motor no longer brakes within 10 sec.	a) Brake needs to be readjusted b) Brake pads are worn c) The brake is defective	→ Adjust the brake according to ⇒ 16.8. If unsuccessful, contact customer service.
Machine whistles when starting	V-belt for drive too loose	→ Retighten V-belt (⇒ 16.6)
Saw blade is braked heavily during machining	V-belt for drive slipping	→ Retighten V-belt (⇒ 16.6)
Bandsaw blade runs untrue	Bandsaw blade tension too low	→ Tension saw blade (⇒ 10.3)
	Upper guide set too high away from workpiece	→ Position guide max. 4 - 5 mm above the workpiece
	Upper and lower guide are not adjusted correctly	→ Adjust side rollers according to section ⇒ 14.1.2
	Welding point not straight	→ Replace saw blade
Machine vibrates strongly	Machine stand uneven	→ Realign (see ⇒ 7.4)
	Drive wheel surfaces Are dirty or damaged	→ Clean / replace
Cutting path is crooked	Saw blade is blunt	→ Resharpen or replace
	Saw blade guide incorrectly adjusted	→ Readjust saw blade guide according to section ⇒ 14.1.2

Continuation on the next ⇒ page

Troubleshooting - Continuation

Fault	Possible Cause	Remedy
Saw blade breaks	Bad weld	→ Replace saw blade
	Too sharp edges at the tooth base	→ Use a saw blade that is suitable for the intended use
	Saw blade guide badly adjusted, the back roller presses against the saw blade	→ Readjust saw blade guide according to section ⇒ 14.1.2
	Manual feed rate too high	→ Select feed rate according to the material
	Saw blade blunt or badly set	→ Replace saw blade
	Saw blade torn or teeth burnt due to incorrect grinding	→ Regrind or replace
	Resin residues or similar on the saw blade	→ Clean the saw blade and the wheel bandages
	Saw blade badly ground or teeth not adapted to the cut	→ Replace saw blade
Red lamp ¹⁰ „Fault“ on the control panel lights up	Fault on the frequency inverter	→ Note the error message and contact customer service. ⚠ Caution: Frequency inverter remains energised for up to 15 minutes after the main switch is turned off!

15.2 Saw Blade Guides - Troubleshooting

Fault	Possible Cause	Remedy
The side rollers or back rollers do not rotate	Insufficient or incorrect lubrication	→ Clean bearings and oil according to section ⇒ 16.3.
	Incorrect basic adjustment of the guide	→ Check basic adjustment (see ⇒ Figure 39) and readjust if necessary (see section ⇒ 14.1.2).
	Poor cleaning	
The back roller is cut by the back of the saw blade	Back roller does not rotate	→ Clean bearings and oil according to section ⇒ 16.3.
	Saw blade runs too far inside on the back roller	→ Check basic adjustment (see ⇒ Figure 39) and readjust if necessary (see section ⇒ 14.1.2).
The running surface of the back roller wears more on the outside than on the inside	Saw blade runs too far too far out on the backrest roller	→ Check basic adjustment (see ⇒ Figure 39) and readjust if necessary (see section ⇒ 14.1.2).
	The back roller is not exactly vertical to the back of the saw blade	
The saw blade is pushed forward by the side rollers	The side rollers are too tight to the saw blade	→ Adjust side rollers correctly according to section ⇒ 14.1.2 and clean dirty parts.
	The running surfaces of the side rollers or saw blade are dirty	

¹⁰ This fault only occurs on models with variable blade speed control.

15.3 Behaviour in the event of a power failure

(only applies to models with electric motor brake)

Bandsaw machines with an electric motor brake are not able to brake the saw drive properly in the event of a power failure or power interruption → The drive will not stop immediately but coast to a standstill.



In the event of a power failure or power interruption, wait until the machine and the bandsaw blade have come to a complete standstill before taking any further action.

- As soon as the power supply has been restored, the bandsaw machine is ready for operation again.
- Then the saw blade drive can be restarted.

Please refer to the following table to find out which brake is installed in your machine:

Motor	Motor brake (standard)	with variable saw blade speed control	with push-button control
1.1 kW	electrical	-	electrical
1.5 kW	electrical	-	electrical
2.2 kW	mechanical	electrical	electrical
3.0 kW	mechanical	electrical	mechanical
4.0 kW	mechanical	electrical	mechanical
5.5 kW	mechanical	electrical	mechanical
7.5 kW	mechanical	electrical	mechanical

16 Maintenance and Inspection



Before any maintenance and inspection work is carried out, chapter ⇨ 5 "Safety" must be read carefully and observed!

Operational malfunctions caused by insufficient or improper maintenance can result in very high repair costs and long machine downtimes. Regular maintenance is therefore essential.

- Clean the machine daily.
- Check all sliding or rolling parts weekly for smooth running and lubricate with a thin-bodied oil if necessary.
- Inspect electrical equipment/components weekly for externally visible damage and have them repaired by a qualified electrician if necessary.
- Immediately remove and replace damaged guards. Never work with damaged equipment!
- Before starting work, check the extraction system for full function every day.
- The extraction system must be checked for obvious defects before initial commissioning, daily and monthly to ensure its effectiveness.
- The air velocity to the extraction system must be checked before the initial commissioning and after significant modifications.
- The function of the gas springs should be checked occasionally. If it takes a lot of force to open the protective cover, the gas springs must be replaced.
- Do not use the machine until these conditions are met.

Due to the different operating conditions, it is not possible to determine in advance how often a wear check, inspection or maintenance is required. Inspection intervals are to be determined appropriately according to the respective operating conditions.

16.1 Replace Ball Bearings

If the ball bearings become noisy or have play, they must be replaced. To do this, the corresponding bandsaw wheel must be removed to make the old ball bearings accessible and replace them with new ones.



Switch off the machine during maintenance and repair work and secure it against being switched on again unexpectedly! Lock the main switch with a padlock!

To remove or install the ball bearings, use a suitable device (e.g. puller / mounting tube) to avoid damaging the bearings. Please refer to the following table for the ball bearing type suitable for your machine:

<i>Model</i>	<i>Ball Bearing Type</i>	<i>Model</i>	<i>Ball Bearing Type</i>
<i>RAPID 400</i>	6204 2RS	<i>RAPID 700</i>	6306 2RS
<i>RAPID 500</i>	6205 2RS	<i>RAPID 800</i>	6307 2RS
<i>RAPID 600</i>	6305 2RS	<i>RAPID 900</i>	6308 2RS

16.2 Lubrication of the Machine

The machine itself does not require lubrication. All ball bearings are maintenance-free.

16.3 Maintenance and Lubrication of the Saw Blade Guides

The bandsaw blade guides should be lubricated every six months with a few drops of manufacturer's special oil (see below). Depending on the frequency of use and the stress, a shorter lubrication interval should be selected.

Maintenance / Cleaning:

Clean the saw blade guides regularly (min. 1 x per week) from sawdust, splinters, resin or other dirt.

Lubrication:

The bright steel parts of the guides are to be kept smooth-running and rust-free at regular intervals by light oiling.

For lubrication we recommend our special oil 1059 (⇒ Figure 52), which is available in the manufacturer's [online shop](#) (content: 5 bottles, 20 ml each).



Figure 52: Special oil 1059



Important: Never use grease to lubricate the bearings!

16.3.1 Oil "GL" Saw Blade Guides

Before oiling the bandsaw blade guides, they must first be cleaned resp. thoroughly freed from sawdust, splinters, resin or other residues and dirt. The procedure is identical for the upper and lower saw blade guides. Always oil the upper and lower guides at the same time.

Oil the side rollers and back roller:

- Apply a few drops of special oil to the running surfaces of the roller axles. roller axles (see marked areas in ⇒ Figure 53).



Figure 53: Oil GL saw blade guides

16.3.2 Oil "APA" Saw Blade Guides

Before oiling the bandsaw blade guides, they must first be cleaned resp. thoroughly freed from sawdust, splinters, resin or other residues and dirt. The procedure is identical for the upper and lower saw blade guides. Always oil the upper and lower guides at the same time.

Oil Side Rollers:

- Remove the sealing plugs from the rollers and put a few drops of oil in the bearings (see ⇒ Figure 54).
- Refit the sealing plugs.
- The O-rings in the side bearing sleeves should occasionally be lubricated with a little acid-free grease (preferably Vaseline).

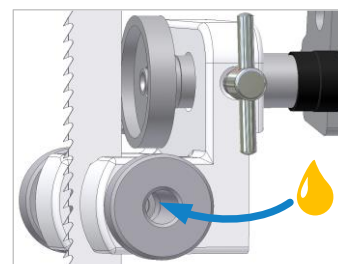

Figure 54: Oil APA side rollers

Oil Back Roller:

- Unscrew the sealing cap from the back roller bearing (⇒ Figure 55).
- Press a little oil into the lubrication hole on the front of the bearing bolt.
- Screw the sealing cap back on.

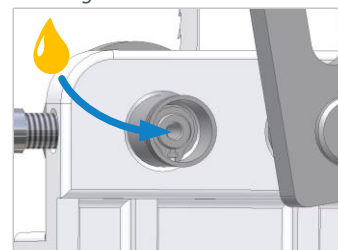

Figure 55: Oil APA back roller

16.4 Bandsaw Roll Coating

The bandsaw roller contact area is made of a specially vulcanised material that is highly resistant to wear and tear. Usually, the surface lasts for many years. If the surface should nevertheless become worn, special cork bandages can be applied, which are available in the manufacturer's [online shop](#). If required, you can also contact our wheel repair service (phone: 0049 7576 / 962 978 - 0 | email: info@beck-maschinenbau.de).

- The running surfaces must always be kept clean and free of incrustations.
- In addition, it must be ensured that the balling is correct and clean.

16.5 Replacing the Bandsaw Blade

As soon as the bandsaw blade cracks, cuts badly, runs untrue or becomes too noisy, it should be replaced. The instructions in section ⇒ 10.3 must be followed. **Note:** Please only use the manufacturer's original bandsaw blades suitable for the bandsaw (see "Accessories" in chapter ⇒ 18).

16.6 Retighten the V-belt(s)



Switch off the machine during maintenance and repair work and secure it against being switched on again unexpectedly! Lock the main switch with a padlock!

- Disconnect the machine from the power supply and secure it or turn off the main switch and lock it.
- Unlock the door safety switch for the lower door according to section ⇒ 10.2 and open the door.
- Slightly loosen the 4 screws (**M**) on the motor.
- Tighten the tensioning nut (**S**) on the threaded rod (**G**) with an open-ended spanner SW17 until the correct V-belt tension is achieved.

Checking the V-belt Tension:

It must be possible to push the belt(s) through by hand between the two axles by approx. 10 mm.

- Tighten the screws (**M**) on the motor again.
- Close the lower bandsaw door again and lock it with the safety switch (see ⇒ 10.2).

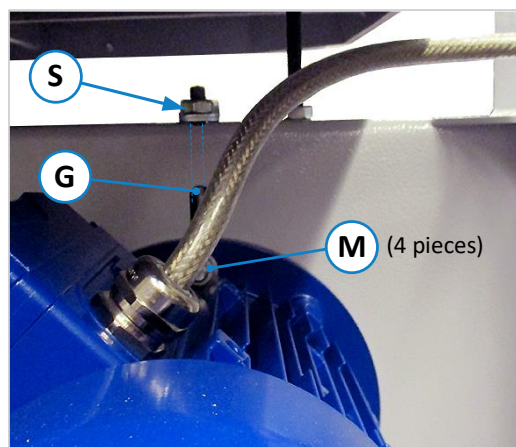

Figure 56: Retighten the V-belt(s)

16.7 Replacing the V-belt(s)

Model	V-belt Type	eff. Length	Quantity	Model	V-belt Type	eff. Length	Quantity
400	SPZ 912 LP / SPZ 912	912 mm	1	700	13 1450 Li	1430 mm	2
500	13 1100 Li (A43)	1130 mm	1	800	13 1475 Li	1452 mm	3
600	13 1100 Li (A43)	1130 mm	1	900	SPZ 1400 LP	1400 mm	4



Switch off the machine during maintenance and repair work and secure it against being switched on again unexpectedly! Lock the main switch with a padlock!



Only V-belts with the same cross-section and length may be used. With models RAPID 700, RAPID 800 and RAPID 900, all V-belts must always be replaced together



Cutting hazard! Wear protective gloves when handling the bandsaw blade!

- Disconnect the machine from the power supply and secure it or turn off the main switch and lock it.
- Unlock the two safety switches according to section ⇒ 10.2 open both bandsaw doors.
- Release the tension on the saw blade (**B**) and remove it (see procedure in section ⇒ 10.3).
- Slightly loosen the 4 screws (**M**) on the motor.
- Loosen the tensioning nut (**S**) on the threaded rod (**G**) until the V-belt is loose.
- Remove the hexagon head screw (**N**) and washer (**U**) from the roller hub.
- Gently pull out the lower bandsaw wheel (**R1**) (please be careful, the wheel is very heavy!).
- Remove belt(s) and insert new belt(s) in the pulley(s) of the bandsaw wheel.
- Refit the lower wheel (**R1**) and reinsert the saw blade.
- Tension belt(s) according to section ⇒ 16.6.
- Close doors and lock with safety switch (see ⇒ 10.2).

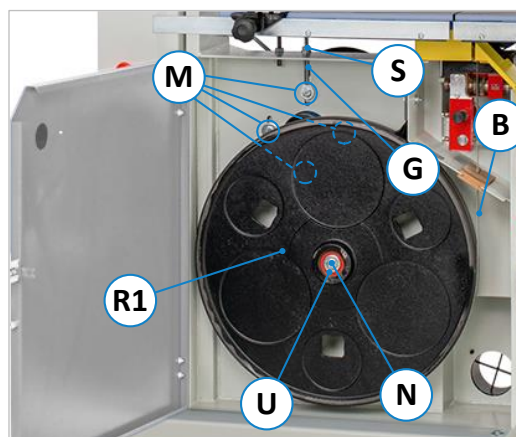

Figure 57: Replacing the V-belt(s)

16.8 Readjusting the Main Motor Brake (2.2 - 3.0 kW)



Switch off the machine during maintenance and repair work and secure it against being switched on again unexpectedly! Lock the main switch with a padlock!

If the machine does not come to a standstill within 10 seconds when braking, the motor brake must be readjusted.

Procedure:

- Disconnect the machine from the power supply and secure it or turn off the main switch and lock it.
- Insert an angled SW5 Allen key through the fan cover and insert it into the hexagon socket of the front-side set screw (see ⇒ Figure 58).
- Turn the Allen key approx. 1/8 turns clockwise as shown in ⇒ Figure 58.



Figure 58: Readjusting the motor brake

16.8.1 Check the Adjustment

- Before checking the adjustment, make sure that the belt is well tensioned (see ⇒ 16.6).
- Then reconnect the machine to the power supply or unlock the main switch and switch on.
- Only for machines with mechanical motor brake → Turn the brake release switch to “active” position.
→ Now it must be possible to move the saw blade by hand. By turning it, you can now check whether the brake is dragging, which means that it has been adjusted too excessively.
→ If the brake is dragging, the readjustment made must be minimally reversed again.



Cutting hazard! Wear protective gloves when handling the bandsaw blade!

- Now turn the brake release switch back to “inactive” position.
- Start the bandsaw blade and wait until the machine has reached full speed.
- Then switch off the bandsaw and check the braking time to standstill.
- If the braking time is still over 10 seconds, repeat the setting procedure (see section ⇒ 16.8) and check the adjustment again.
- If the adjustment was not successful, please contact the customer service of the manufacturer.



If rattling noises occur in the area of the fan blade when turning the motor, please contact the customer service. Possibly the brake lining is worn out.

16.9 Readjusting the Main Motor Brake (4.0 - 7.5 kW)

The motor brake cannot be readjusted on these models. If you have problems with the motor brake, please contact our customer service (phone: 0049 7576 / 962 978 - 0).

16.10 Models with Electric Motor Brake

The motor brake cannot be readjusted for motors from 1.1 to 1.5 kW, as these are equipped with an electric motor brake. The same applies to bandsaws with the option “Variable Saw Blade Speed Control” and for 2.2 kW motors with the option “Push-Switch Panel”. If you have problems with the motor brake, please contact our customer service (phone: 0049 7576 / 962 978 - 0).

17 Disassembly and Scrapping

When dismantling and scrapping the machine, the current EU regulations or the respective regulations and laws of the country of operation, which are prescribed for proper dismantling and disposal, must be observed. The aim is to dismantle the machine and its various materials and components properly, to recycle all possible parts and to dispose of non-recyclable components in the most environmentally friendly way.

	<p>Please pay particular attention to</p> <ul style="list-style-type: none"> • <i>the dismantling of the machine in the working area</i> • <i>proper dismantling of the machine and accessories</i> • <i>a safe and proper removal of the machine</i> • <i>proper separation of all components and materials.</i>
---	--

When dismantling and disposing the machine, the laws and regulations in force at the place of use concerning health and environmental protection must be observed.

	<p>Remove all residues of oil, grease and other lubricants and have them disposed of properly by a qualified disposal company.</p>
---	---

When separating, disposing of or recycling the machine materials, comply with the environmental protection laws in force at the place of use regarding the disposal of industrial solid waste toxic and hazardous waste.

	<ul style="list-style-type: none"> • <i>Hoses and plastic parts as well as other components that are not made of metal must be dismantled and recycled or disposed of separately.</i> • <i>Electrical components such as cables, switches, connectors, transformers, etc. must be removed and (if possible) recycled or otherwise disposed of in a qualified manner.</i> • <i>Pneumatic and hydraulic parts such as valves, solenoid valves, pressure regulators, etc. must be removed and (if possible) recycled or otherwise disposed of in a qualified manner.</i> • <i>Dismantle the base frame and all metal parts of the machine and sort them according to material type. Metals can be melted down and recycled.</i>
--	--

In the event of improper disposal of lubricants, the following residual risks to the environment and health exist:

	<p>Pollution of the environment by seepage into groundwater or sewage system.</p>
---	--

	<p>Poisoning of the personnel contracted for the disposal.</p>
---	---

Note: The disposal of lubricants considered toxic and hazardous must be carried out in accordance with the regulations and laws in force at the respective place of use. Only qualified disposal companies that have the appropriate permits for the disposal of used oil and lubricants are to be commissioned with the disposal.

18 Options and Accessories

In the following tables you will find available options and accessories for each RAPID bandsaw model. General spare parts such as cork bandages, table inserts, special oil for bandsaw blade guides etc. can be found in the online shop <https://www.hokubema.com>.

	<p>Only use original bandsaw blades, accessories and spare parts specified by the manufacturer. The use of other accessories or spare parts can cause injury to persons and damage to the machine. The manufacturer accepts no liability for any damage resulting from the use of non-prescribed accessories and spare parts or additional components from third parties!</p>
---	--

18.1 RAPID 400 - Bandsaw Blades

Blade Length	Width	Thickness	Span Width	Quality	Art. No.
3300 mm	20	0.45 mm	6	1002	3783.20G
3300 mm	15	0.45 mm	6	1002	3783.15G
3300 mm	10	0.40 mm	6	1002	3783.10G

18.2 RAPID 400 - Options and Accessories

Article	Description	Art.-No.
PRECISION BANDSAW BLADE GUIDE	Top and bottom, type APA 2, size 1 (instead of type GL).	5211
FOLDABLE MITRE FENCE TOP	Can be mounted laterally (on the right of the machine table). Only for column-left version.	4360
T-SLOT IN MACHINE TABLE	For mitre fence Basic (see following Art. No. 5206).	5208
MITRE FENCE BASIC	Can be mounted if the option "T-Slot in Machine Table" is available	5206
STRONGER MOTOR	1.5 kW, 400 V / 50 HZ instead of standard motor 1.1 kW.	5213
SINGLE-PHASE MOTOR	1.1 kW, 230 V / 50 HZ instead of 3-phase standard motor 1.1 kW.	5214
SPECIAL VOLTAGE	220 V / 50 HZ up to 4 kW.	4600
EMERGENCY STOP	Designed as impact button.	5210
FIXATION RAILS	2 pieces (Length = 430 mm), for quick and safe attachment of safety and working devices.	5277
TABLE EXTENSION	For suspension in fastening rail, replaces an assistant when machining long workpieces.	5279
KREISFIX	The practical aid for circular cutting, enables precise cutting of curves and discs without scribing, and is very easy to handle (only in conjunction with table extension part No. 5279).	5280
CROWNING	For curved cutting of narrow parts.	4930
MEASUREMENT SCALE ON TABLE	For exact dimensioning of the fence.	5209
MOVING TROLLEY	With 2 swivel castors with brakes and 2 fixed castors.	5216

18.3 RAPID 500 - Bandsaw Blades

Blade Length	Width	Thickness	Span Width	Quality	Art. No.
4140 mm	25	0.45 mm	7	1002	3783.25K
4140 mm	20	0.45 mm	6	1002	3783.20K
4140 mm	15	0.45 mm	6	1002	3783.15K
4140 mm	10	0.40 mm	6	1002	3783.10K

18.4 RAPID 500 - Options and Accessories

Article	Description	Art.-No.
PRECISION BANDSAW BLADE GUIDE	Top and bottom, type APA 2, size 1 (instead of type GL).	5211
FOLDABLE MITRE FENCE TOP	Can be mounted laterally (on the right of the machine table). Only for column-left version.	4362
T-SLOT IN MACHINE TABLE	For mitre fence Basic (see following Art. No. 5206).	5208
MITRE FENCE BASIC	Can be mounted if the option "T-Slot in Machine Table" is available	5206
COLUMN-RIGHT VERSION	With steel table. Seen from the workpiece feed side, the machine body is to the right of the saw blade.	5221
TABLE SWIVEL DEVICE	For infinitely variable table inclination up to 45° via hand crank.	5222
T-SLOT IN MACHINE TABLE	For mitre fence Basic (see following Art. No. 5206).	5208
STRONGER MOTOR	2.2 KW 400 V / 50 HZ instead of standard motor 1.5 kW.	5218
SINGLE-PHASE MOTOR	1.5 kW, 230 V / 50 HZ instead of 3-phase standard motor 1.5 kW.	5219
SPECIAL VOLTAGE	220 V / 50 HZ up to 4 kW.	4600
EMERGENCY STOP	Designed as impact button.	5210
FIXATION RAILS	2 pieces (Length = 430 mm), for quick and safe attachment of safety and working devices.	5277
TABLE EXTENSION	For suspension in fastening rail, replaces an assistant when machining long workpieces.	5279
KREISFIX	The practical aid for circular cutting, enables precise cutting of curves and discs without scribing, and is very easy to handle (only in conjunction with table extension part No. 5279).	5280
CROWNING	For curved cutting of narrow parts.	4930
MEASUREMENT SCALE ON TABLE	For exact dimensioning of the fence.	5209
PUSH-SWITCH UNIT 1.5 KW	Control panel with separate push switches for bandsaw on/off and with wear-free electric motor brake.	5221
MOVING TROLLEY	With 2 swivel castors with brakes and 2 fixed castors.	5224

18.5 RAPID 600 - Bandsaw Blades

Blade Length	Width	Thickness	Span Width	Quality	Art. No.
4735 mm	20	0.60 mm	9	1000	3780.25D
4735 mm	15	0.70 mm	8	1000	3780.20D
4735 mm	10	0.70 mm	6	1000	3780.10D

18.6 RAPID 600 - Options and Accessories

Article	Description	Art. No.
PRECISION BANDSAW BLADE GUIDE	Top and bottom, type APA 2, size 2 (instead of type GL).	5217
UPPER & LOWER BACK ROLLER WITH BALL BEARING	With replaceable rim, maintenance-free for difficult-to-machine wood materials or non-ferrous metals, instead of standard back roller for band-saw guide APA 2, size 2.	5000
FOLDABLE MITRE FENCE TOP	Can be mounted laterally (on the right of the machine table). Only for column-left version.	4362
T-SLOT IN MACHINE TABLE	For mitre fence Basic (see following Art. No. 5225).	5227
MITRE FENCE BASIC	Can be mounted if the option "T-Slot in Machine Table" is available	5225
COLUMN-RIGHT VERSION	With steel table. Seen from the workpiece feed side, the machine body is to the right of the saw blade.	5231
TABLE SWIVEL DEVICE	For infinitely variable table inclination up to 45° via hand crank.	5222
STRONGER MOTOR	3,0 KW 400 V / 50 HZ instead of standard motor 2.2 kW.	5228
SINGLE-PHASE MOTOR	1,85 kW, 230 V / 50 HZ instead of 3-phase standard motor 2.2 kW.	5229
SPECIAL VOLTAGE	220 V / 50 HZ up to 4 kW.	4600
EMERGENCY STOP	Designed as impact button.	5210
PUSH-SWITCH UNIT	With automatic star-delta start (from 3 kW motor), Emergency stop switch included.	5234
PUSH-SWITCH UNIT	Instead of rotary cam switch, with direct start (for 2.2 kW motor), including wear-free electric motor brake.	5261
VARIABLE BANDSAW BLADE SPEED CONTROL	From approx. 310 - 1860 m/min via frequency inverter with push-button unit incl. digital display and wear-free motor brake.	5312
CUTTING HEIGHT PLUS 220 MM	Only for column-left version!	5232
LASER CUT POSITION INDICATOR	As a visual aid for precise and targeted cuts, with power connection via socket on the machine.	5212
FIXATION RAILS	2 pieces (Length = 430 mm), for quick and safe attachment of safety and working devices.	5277
TABLE EXTENSION	For suspension in fastening rail, replaces an assistant when machining long workpieces.	5279
KREISFIX	The practical aid for circular cutting, enables precise cutting of curves and discs without scribing, and is very easy to handle (only in conjunction with table extension part No. 5279).	5280
CROWNING	For curved cutting of narrow parts.	4930
MEASUREMENT SCALE ON TABLE	For exact dimensioning of the fence.	5209
MOVING TROLLEY	With 2 swivel castors with brakes and 2 fixed castors.	5235

18.7 RAPID 700 - Bandsaw Blades

Blade Length	Width	Thickness	Span Width	Quality	Art. No.
5140 mm	35	0.80 mm	10	1000	3780.35F
5140 mm	30	0.80 mm	9	1000	3780.30F
5140 mm	25	0.70 mm	9	1000	3780.25F
5140 mm	20	0.70 mm	8	1000	3780.20F
5140 mm	15	0.70 mm	7	1000	3780.15F

18.8 RAPID 700 - Options and Accessories

Article	Description	Art. No.
PRECISION BANDSAW BLADE GUIDE	Top and bottom, type APA 2, size 2 (instead of type GL).	5217
UPPER & LOWER BACK ROLLER WITH BALL BEARING	With replaceable rim, maintenance-free for difficult-to-machine wood materials or non-ferrous metals, instead of standard back roller for band-saw guide APA 2, size 2.	5000
FOLDABLE MITRE FENCE TOP	Can be mounted laterally (on the right of the machine table). Only for column-left version.	4361
T-SLOT IN MACHINE TABLE	For mitre fence Basic (see following Art. No. 5225).	5227
MITRE FENCE BASIC	Can be mounted if the option "T-Slot in Machine Table" is available	5225
COLUMN-RIGHT VERSION	With steel table. Seen from the workpiece feed side, the machine body is to the right of the saw blade.	5238
TABLE SWIVEL DEVICE	For infinitely variable table inclination up to 45° via hand crank.	5251
STRONGER MOTOR	4.0 KW 400 V / 50 HZ instead of 3.0 kW standard motor.	5236
PUSH-SWITCH UNIT	With automatic star-delta start, Emergency stop switch included.	5254
VARIABLE BANDSAW BLADE SPEED CONTROL	From approx. 314 - 1884 m/min via frequency inverter with push-button unit incl. digital display and wear-free motor brake.	5308
CUTTING HEIGHT PLUS 220 MM	Only for column-left version!	5240
CUTTING HEIGHT PLUS 400 MM	Only for column-left version!	5242
SPECIAL VOLTAGE	220 V / 50 HZ up to 4 kW.	4600
SPECIAL VOLTAGE	220 V / 50 HZ up to 7.5 kW.	4601
EMERGENCY STOP	Designed as impact button.	5210
LASER CUT POSITION INDICATOR	As a visual aid for precise and targeted cuts, with power connection via socket on the machine.	5212
FIXATION RAILS	2 pieces (Length = 530 mm), for quick and safe attachment of safety and working devices.	5278
TABLE EXTENSION	For suspension in fastening rail, replaces an assistant when machining long workpieces.	5279
KREISFIX	The practical aid for circular cutting, enables precise cutting of curves and discs without scribing, and is very easy to handle (only in conjunction with table extension part No. 5279).	5280
CROWNING	For curved cutting of narrow parts.	4930
MEASUREMENT SCALE ON TABLE	For exact dimensioning of the fence.	5123
MOVING TROLLEY	With 2 swivel castors with brakes and 2 fixed castors.	5244

18.9 RAPID 800 - Bandsaw Blades

Blade Length	Width	Thickness	Span Width	Quality	Art. No.
5775 mm	40	0.80 mm	12	1001	3781.40I
5775 mm	35	0.80 mm	10	1000	3780.35I
5775 mm	30	0.80 mm	9	1000	3780.30I
5775 mm	25	0.70 mm	9	1000	3780.25I
5775 mm	20	0.70 mm	8	1000	3780.20I
5775 mm	15	0.70 mm	7	1001	3781.15I

18.10 RAPID 800 - Options and Accessories

Article	Description	Art. No.
PRECISION BANDSAW BLADE GUIDE	Top and bottom, type APA 2, size 2 (instead of type GL).	5217
UPPER & LOWER BACK ROLLER WITH BALL BEARING	With replaceable rim, maintenance-free for difficult-to-machine wood materials or non-ferrous metals, instead of standard back roller for band-saw guide APA 2, size 2.	5000
FOLDABLE MITRE FENCE TOP	Can be mounted laterally (on the right of the machine table). Only for column-left version.	4361
T-SLOT IN MACHINE TABLE	For mitre fence Basic (see following Art. No. 5245).	5247
MITRE FENCE BASIC	Can be mounted if the option "T-Slot in Machine Table" is available	5245
COLUMN-RIGHT VERSION	With steel table. Seen from the workpiece feed side, the machine body is to the right of the saw blade.	5250
TABLE SWIVEL DEVICE	For infinitely variable table inclination up to 45° via hand crank.	5251
STRONGER MOTOR	5.5 KW 400 V / 50 HZ, instead of 4.0 kW standard motor.	5248
PUSH-SWITCH UNIT	With automatic star-delta start, Emergency stop switch included.	5254
VARIABLE BANDSAW BLADE SPEED CONTROL	From approx. 360 - 2160 m/min via frequency inverter with push-button unit incl. digital display and wear-free motor brake.	5316
CUTTING HEIGHT PLUS 220 MM	Only for column-left version!	5252
CUTTING HEIGHT PLUS 400 MM	Only for column-left version!	5255
SPECIAL VOLTAGE	220 V / 50 HZ up to 7.5 kW.	4601
EMERGENCY STOP	Designed as impact button.	5210
LASER CUT POSITION INDICATOR	As a visual aid for precise and targeted cuts, with power connection via socket on the machine.	5212
FIXATION RAILS	2 pieces (Length = 530 mm), for quick and safe attachment of safety and working devices.	5278
TABLE EXTENSION	For suspension in fastening rail, replaces an assistant when machining long workpieces.	5279
KREISFIX	The practical aid for circular cutting, enables precise cutting of curves and discs without scribing, and is very easy to handle (only in conjunction with table extension part No. 5279).	5280
CROWNING	For curved cutting of narrow parts.	4930
MEASUREMENT SCALE ON TABLE	For exact dimensioning of the fence.	5209
MOVING TROLLEY	With 2 swivel castors with brakes and 2 fixed castors.	5256

18.11 RAPID 900 - Bandsaw Blades

Blade Length	Width	Thickness	Span Width	Quality	Art. No.
6260 mm	40	0.80 mm	12	1001	3781.40L
6260 mm	35	0.80 mm	10	1000	3780.35L
6260 mm	30	0.80 mm	9	1000	3780.30L
6260 mm	25	0.70 mm	9	1000	3780.25L
6260 mm	20	0.70 mm	8	1001	3781.20L
6260 mm	15	0.70 mm	7	1001	3781.15L

18.12 RAPID 900 - Options and Accessories

Article	Description	Art. No.
PRECISION BANDSAW BLADE GUIDE	Top and bottom, type APA 2, size 2 (instead of type GL).	5268
UPPER & LOWER BACK ROLLER WITH BALL BEARING	With replaceable rim, maintenance-free for difficult-to-machine wood materials or non-ferrous metals, instead of standard back roller for band-saw guide APA 2, size 2.	5000
FOLDABLE MITRE FENCE TOP	Can be mounted laterally (on the right of the machine table). Only for column-left version.	4361
T-SLOT IN MACHINE TABLE	For mitre fence Basic (see following Art. No. 5245).	5247
MITRE FENCE BASIC	Can be mounted if the option "T-Slot in Machine Table" is available	5245
TABLE SWIVEL DEVICE	For infinitely variable table inclination up to 45° via hand crank.	5177
VERSTÄRKTER MOTOR	7.5 kW 400 V / 50 Hz instead of 5.5 kW standard motor, with rotary cam switch.	5257
PUSH-SWITCH UNIT	With automatic star-delta start, Emergency stop switch included.	5254
VARIABLE BANDSAW BLADE SPEED CONTROL	From approx. 360 - 2160 m/min via frequency inverter with push-button unit incl. digital display and wear-free motor brake.	5311
CUTTING HEIGHT PLUS 220 MM	Only for column-left version!	5259
SPECIAL VOLTAGE	220 V / 50 HZ up to 7.5 kW.	4601
EMERGENCY STOP	Designed as impact button.	5210
LASER CUT POSITION INDICATOR	As a visual aid for precise and targeted cuts, with power connection via socket on the machine.	5212
FIXATION RAILS	2 pieces (Length = 530 mm), for quick and safe attachment of safety and working devices.	5278
TABLE EXTENSION	For suspension in fastening rail, replaces an assistant when machining long workpieces.	5279
KREISFIX	The practical aid for circular cutting, enables precise cutting of curves and discs without scribing, and is very easy to handle (only in conjunction with table extension part No. 5279).	5280
CROWNING	For curved cutting of narrow parts.	4930
MEASUREMENT SCALE ON TABLE	For exact dimensioning of the fence.	5209

EU - Declaration of Conformity

in accordance with the EU Machinery Directive 2006/42/EC Annex II A

The manufacturer,

Reinhold Beck Maschinenbau GmbH
Im Grund 23
D-72505 Krauchenwies

Phone: +49 (0) 7576 / 962 978 - 0
Fax: +49 (0) 7576 / 962 978 - 90

hereby declares that the manufactured machine

Bandsaw Machine TYPE RAPID 400 | 500 | 600 | 700 | 800 | 900

Machine-No.:

Year of manufacture:

in the version provided complies with the following directives:

- Machinery Directive 2006/42/EC
- EMC Directive 2014/30/EU

Harmonised standards applied, in particular:

- EN 1807-1

The notified body (0392)

DGUV Test
Prüf- und Zertifizierungsstelle Holz
Fachbereich Holz und Metall
Vollmoellerstraße 11
70563 Stuttgart (Germany)

has carried out an EC type-examination for the above machine.

Type Examination Certificate No.: **HO 141058 (EG)** and **HO141059 (GS)**

Krauchenwies, 23/11/2023

.....



.....
Reinhold Beck
Managing Director