

TRANSLATION OF THE ORIGINAL VERSION



CE

# Operating Manual

Bandsaw Series

**WOOD**PECKER BSM 7-40 | 7-50 | 7-60



BSM 7-40



BSM 7-50



BSM 7-60

Valid for: **Bandsaws BSM 7-40 | 7-50 | 7-60**

**WOOD**PECKER

**HOKUBEMA Maschinenbau GmbH**

Graf-Stauffenberg-Kaserne, Binger Str. 28 | Halle 120

DE 72488 Sigmaringen | Tel. +49 07571 755-0

E-Mail: [info@ichbinwoodpecker.de](mailto:info@ichbinwoodpecker.de) | Web: <https://www.ichbinwoodpecker.de>

**Space for notes:**



**HOKUBEMA Maschinenbau GmbH**

Graf-Stauffenberg-Kaserne  
Binger Straße 28 | Halle 120  
DE 72488 Sigmaringen  
Tel.: +49 (0)7571-755-0  
Fax: +49 (0)7571-755-222

<h2>Handover Certificate</h2>			
<b>Machine type:</b>			
<b>Machine no.:</b>			
<b>Construction year:</b>			
<b>Customer address (location of the machine):</b>			
<b>Name:</b>			
<b>Street:</b>			
<b>Postcode/City:</b>			
<b>Phone:</b>	<b>Fax:</b>		
<b>E-mail:</b>			
<b>Warranty:</b> On the basis of our Terms and Conditions of Sale, Delivery and Payment of the respective current status, we assume a warranty of <b>12 months</b> , calculated from the day of delivery, for material defects and defects of title in connection with the delivery for the above-mentioned machine.			
<b>Warranty claims:</b> <b>Warranty claims on the part of HOKUBEMA Maschinenbau GmbH only exist if we have received the signed handover certificate</b> and the machine has been properly commissioned. We therefore ask for immediate return. <b>Important:</b> Please read and follow the instructions in chapter ⇨ 1 " <b>Liability and Warranty</b> ".			
<b>Confirmation of the buyer:</b> <input checked="" type="checkbox"/> The machine described above was purchased by me/us. <input checked="" type="checkbox"/> Together with this handover certificate, I have received the operating manual valid for the machine (edition: _____). <input checked="" type="checkbox"/> The operating instructions have been read and understood by me, as well as by all persons responsible for operating the specified machine. I will ensure that persons working on the machine at a later date are also instructed accordingly.			
_____	_____	_____	
Name and position	Date	Signature of the customer	
<b>Address of the dealer (company stamp):</b>		The machine, including the operating manual, was handed over to the buyer and installed according to the specifications in the operating manual.	
		_____	
		Date	Signature - Customer Service

**Space for notes:**

**HOKUBEMA Maschinenbau GmbH**

Graf-Stauffenberg-Kaserne  
Binger Straße 28 | Halle 120  
DE 72488 Sigmaringen  
Tel.: +49 (0)7571-755-0  
Fax: +49 (0)7571-755-222

<h2>Handover Certificate</h2>			
<b>Machine type:</b>			
<b>Machine no.:</b>			
<b>Construction year:</b>			
<b>Customer address (location of the machine):</b>			
<b>Name:</b>			
<b>Street:</b>			
<b>Postcode/City:</b>			
<b>Phone:</b>	<b>Fax:</b>		
<b>E-mail:</b>			
<b>Warranty:</b> On the basis of our Terms and Conditions of Sale, Delivery and Payment of the respective current status, we assume a warranty of <b>12 months</b> , calculated from the day of delivery, for material defects and defects of title in connection with the delivery for the above-mentioned machine.			
<b>Warranty claims:</b> <b>Warranty claims on the part of HOKUBEMA Maschinenbau GmbH only exist if we have received the signed handover certificate</b> and the machine has been properly commissioned. We therefore ask for immediate return. <b>Important:</b> Please read and follow the instructions in chapter ⇨ 1 " <b>Liability and Warranty</b> ".			
<b>Confirmation of the buyer:</b> <input checked="" type="checkbox"/> The machine described above was purchased by me/us. <input checked="" type="checkbox"/> Together with this handover certificate, I have received the operating manual valid for the machine (edition: _____). <input checked="" type="checkbox"/> The operating instructions have been read and understood by me, as well as by all persons responsible for operating the specified machine. I will ensure that persons working on the machine at a later date are also instructed accordingly.			
_____	_____	_____	
Name and position	Date	Signature of the customer	
<b>Address of the dealer (company stamp):</b>		The machine, including the operating manual, was handed over to the buyer and installed according to the specifications in the operating manual.	
		_____	
		Date	Signature - Customer Service

# Table of Contents

1	Liability and Warranty .....	10
2	Introduction.....	11
2.1	Legal Notice.....	11
2.2	Illustrations .....	11
3	Symbols .....	11
3.1	General Symbols .....	11
3.2	Symbols in Safety Instructions.....	12
4	General .....	13
4.1	Structure of the Machine .....	13
4.2	Target Group and Previous Experience .....	13
4.3	Requirements for the Operators .....	13
4.4	Accident Prevention .....	14
4.5	General Safety Regulations .....	14
4.6	Machine Description .....	14
4.7	About the “BSM” Series .....	15
4.8	Standard Equipment .....	15
4.9	Available Accessories .....	15
5	Safety.....	16
5.1	Basic Safety Instructions.....	16
5.1.1	Application Area and Intended Use.....	16
5.1.2	Modifications and Conversions to the Machine .....	16
5.1.3	Connection to a Central Emergency Stop Switch.....	16
5.1.4	Residual Risks .....	17
5.1.5	Observe the Environmental Protection Regulations.....	18
5.1.6	Organisational Measures.....	18
5.1.7	Personnel Selection and Qualification - Basic Duties.....	19
5.1.8	Training of Personnel.....	19
5.2	Safety Instructions for Specific Phases of Operation .....	20
5.2.1	Before starting Work .....	20
5.2.2	Normal Operation .....	20
5.2.3	Special work within the Scope of Maintenance Work as well as Troubleshooting in the Workflow .....	21
5.2.4	Safe Work Practices.....	22
5.2.5	Safety Equipment .....	22
5.2.6	Noise .....	22
5.3	Danger Zones on the Bandsaw .....	23
5.3.1	Danger Zone Bandsaw Blade .....	23
5.3.2	Danger Zone around the Machine.....	23
6	Machine Data .....	24
6.1	Series and Expandability .....	24
6.2	Technical Specifications .....	25
6.3	Dimensions.....	25
6.4	Emission Levels according to EN ISO 3746:2010 .....	26
6.4.1	Noise Information.....	26

6.4.2	Noise Emission Values .....	26
6.4.3	Dust Emission according to GS-HO-05 in mg/m <sup>3</sup> air .....	26
6.4.4	Extraction .....	26
<b>7</b>	<b>Installation and Connection.....</b>	<b>27</b>
7.1	Check Delivery Conditions.....	27
7.2	Transport to the Installation Site.....	27
7.2.1	Transport.....	27
7.3	Installing the Machine.....	27
7.4	Temporary Storage.....	28
7.5	Lashing on a Transport Vehicle .....	28
7.5.1	Lashing the Bandsaw .....	28
7.6	Connecting the Extraction Unit .....	29
7.7	Electrical Connections .....	30
<b>8</b>	<b>Components and Controls.....</b>	<b>31</b>
<b>9</b>	<b>Commissioning .....</b>	<b>32</b>
9.1	Switching ON and OFF.....	32
9.1.1	BSM 7-40 and BSM 7-50.....	32
9.1.2	BSM 7-60.....	32
9.2	Frequent switching ON and OFF in succession .....	33
<b>10</b>	<b>Settings and Operation.....</b>	<b>33</b>
10.1	Basic Factory Setting .....	33
10.2	Door Interlock with Safety Switches.....	34
10.3	Inserting and Tensioning a Bandsaw Blade .....	35
10.4	Adjusting the upper Bandsaw Wheel .....	36
10.5	Height adjustment of the upper Saw Blade Guide .....	36
10.6	Swivel Table .....	36
10.7	Adjusting the GL Bandsaw Guides.....	37
10.7.1	Structure and Components .....	37
10.7.2	Adjusting the GL Saw Blade Guides .....	37
10.7.3	Basic Setting of the Back and Side Rollers (Overview) .....	38
<b>11</b>	<b>Using the Rip Fence .....</b>	<b>39</b>
11.1	Convert the Fence to the Right of the Saw Blade.....	39
<b>12</b>	<b>Replace Table Insert .....</b>	<b>39</b>
<b>13</b>	<b>General Instructions for Use.....</b>	<b>40</b>
13.1	Bandsaw Blades .....	40
13.2	Use of the Machine .....	40
13.3	Completion of the Work.....	42
<b>14</b>	<b>Optional Components .....</b>	<b>43</b>
14.1	APA 2 - Saw Blade Guides.....	43
14.1.1	Structure and Components .....	43
14.1.2	Adjusting the APA Saw Blade Guides.....	43
14.1.3	Basic Setting of the Back and Side Rollers (Overview) .....	44
14.1.4	Conversion to Left Version .....	44
14.2	Measurement Scale on the Table.....	45



14.3	T-Slot in the Table Top (including Mitre Fence).....	45
14.4	Table Extension .....	45
14.5	Kreisfix for Circular Cuts .....	45
14.6	Machine Moving Trolley.....	45
15	Troubleshooting .....	46
15.1.1	Saw Blade Guides - Troubleshooting .....	47
16	Maintenance and Inspection .....	48
16.1	Replace Ball Bearings .....	48
16.2	Lubrication of the Machine .....	49
16.3	Maintenance and Lubrication of the Saw Blade Guides .....	49
16.3.1	Oil "GL" Saw Blade Guides.....	49
16.3.2	Oil "APA" Saw Blade Guides .....	49
16.4	Bandsaw Roll Coating.....	50
16.5	Replacing the Bandsaw Blade.....	50
16.6	Retighten the V-belt .....	51
16.7	Replacing the V-belt .....	51
16.8	Readjusting the BSM 7 -60 Main Motor Brake .....	52
16.8.1	Check the Adjustment .....	52
16.9	Motor Brake on Models BSM 7-40 and BSM 7-50.....	52
17	Disassembly and Scrapping .....	53
18	Options and Accessories.....	54
18.1	BSM 7-40 - Bandsaw Blades .....	54
18.2	BSM 7-40 - Options and Accessories .....	54
18.3	BSM 7-50 - Bandsaw Blades .....	55
18.4	BSM 7-50 - Options and Accessories .....	55
18.5	BSM 7-60 - Bandsaw Blades .....	56
18.6	BSM 7-60 - Options and Accessories .....	56
	EU - Declaration of Conformity.....	57



## List of Figures

Figure 1: Bandsaw blade .....	11
Figure 2: Danger zone saw blade .....	23
Figure 3: Danger zone around the machine .....	23
Figure 4: Nameplate .....	24
Figure 5: Bandsaw series BSM .....	24
Figure 6: Dimensions .....	25
Figure 7: Transport .....	27
Figure 8: Lashing the bandsaw for transport .....	28
Figure 9: Suction nozzles .....	29
Figure 10: Connections in the terminal box .....	30
Figure 11: Components and controls .....	31
Figure 12: Push-buttons .....	32
Figure 13: Rotary switch with locking latch .....	32
Figure 14: Factory adjustment points .....	33
Figure 15: Safety switch - door unlocked .....	34
Figure 16: Safety switch - door locked .....	34
Figure 17: Overview - Inserting and tensioning the bandsaw blade .....	35
Figure 18: Bandsaw wheel adjustment .....	36
Figure 19: Lever for height adjustment .....	36
Figure 20: Adjust table inclination .....	36
Figure 21: GL 456 - Structure and components .....	37
Figure 22: Adjusting the GL saw blade guides .....	37
Figure 23: Basic adjustment of the back and side rollers .....	38
Figure 24: Fence in high position .....	39
Figure 25: Fence turned to flat position .....	39
Figure 26: Converting the fence .....	39
Figure 27: Table insert .....	39
Figure 28: Table extensions and tools .....	41
Figure 29: APA - Structure and components .....	43
Figure 30: Adjusting the guides .....	43
Figure 31: Basic adjustment of the back and side rollers .....	44
Figure 32: Convert bottom guide to left .....	44
Figure 33: Convert top guide to left .....	44
Figure 34: Measurement scale on the table .....	45
Figure 35: Mitre fence „Basic“ .....	45
Figure 36: Table extension .....	45
Figure 37: Kreisfix for circular cuts .....	45
Figure 38: Machine moving trolley .....	45
Figure 39: Special oil 1059 .....	49
Figure 40: Oil GL saw blade guides .....	49
Figure 41: Oil APA side rollers .....	49
Figure 42: Oil APA back roller .....	49
Figure 43: Retighten the V-belt .....	51
Figure 44: Replacing the V-belt .....	51
Figure 45: Readjusting the BSM 7-60 motor brake .....	52

### Revisions:

Revision	Editor	Modification	Date
001	AG	Original manual translated	21.04.2022

# 1 Liability and Warranty

When purchasing a machine or additional component (hereinafter referred to as “machine”), the General Terms and Conditions of Sale and Delivery of HOKUBEMA Maschinenbau GmbH generally apply. These are provided to the purchaser or operator at the latest when the contract is concluded.



**IMPORTANT NOTE:** *Liability and warranty claims shall only commence from the point in time at which the signed handover certificate (see ⇒ page 3 resp. 5) from the dealer and/or end customer for the delivered machine has been submitted to HOKUBEMA Maschinenbau GmbH in written form.*

Liability and warranty claims for personal injury and property damage are generally excluded if they are due to one or more of the following causes:

- Commissioning of the machine without prior machine instruction by an authorised and adequately trained specialist who is familiar with the function and dangers of the machine.
- Electrical connection as well as repair and/or maintenance work on electrical components by personnel who do not have the appropriate qualifications.
- Connection and repair and/or maintenance work on hydraulic or pneumatic components by personnel who do not have the appropriate qualifications.
- Non-observance of the instructions in the operating manual, in particular the chapter “Safety”.
- Improper use or operation in an unauthorised area of application.
- Improper assembly, commissioning, operation and maintenance of the machine.
- Unauthorised conversions or modifications to the machine or additional components.
- Operating the machine without using all the protective equipment available for the operation.
- Inadequate monitoring and maintenance of the machine components and protective devices.
- Continuing to operate the machine when faults, damage or defects are present.
- Processing materials that do not correspond to the machine's area of application.
- Carrying out operations that are not permitted for the machine supplied.
- Use of tools that are not permitted for the machine supplied.
- Operating the machine outdoors or in damp, wet or potentially explosive environments.
- Operation of the machine outside permissible ambient temperatures or humidity.
- Grossly negligent behaviour when handling or operating the machine.
- Impact by foreign bodies, e.g. stones, metal parts, etc.
- Improperly carried out repairs.
- Catastrophic events due to force majeure.

## 2 Introduction

This operating manual covers the three bandsaw machines of the series Woodpecker BSM 7-40, 7-60 and 7-60. The purpose of this document is to acquaint the user with the machine and enable him to use it to the full extent of its intended capabilities.

Additionally it contains important information to operate the machine safely, properly and economically.

Observance of the manual helps to avoid hazards, reduce repair costs and downtimes and increase the reliability and service life of the machine.

Furthermore, this operating manual serves to supplement instructions based on national regulations for accident prevention and environmental protection.

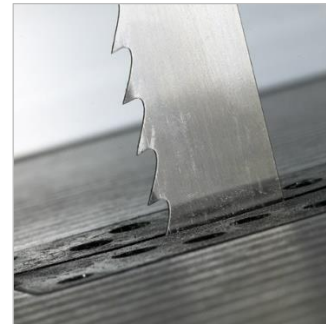

Figure 1: Bandsaw blade

	<p><b><i>This operating manual must always be available at the place of use of the machine. It must be read and followed by every person who is assigned to work on the machine, e.g.</i></b></p> <ul style="list-style-type: none"> <li>• <i>during operation, including set-up, troubleshooting in the work process, removal of production waste and maintenance,</i></li> <li>• <i>during maintenance (servicing, inspection, repair)</i></li> <li>• <i>and/or during transport.)</i></li> </ul>
--	---

Apart from the operating manual and the legally binding accident prevention provisions applicable in the country and place of use, the recognized technical regulations for safe and proper work must also be observed.

### 2.1 Legal Notice

WOODPECKER is a brand of Hokubema Maschinenbau GmbH. All contents of these operating instructions are subject to the rights of use and copyright of HOKUBEMA Maschinenbau GmbH. Any reproduction, modification, further use and publication in other electronic or printed media, as well as their online publication, requires the prior written consent of HOKUBEMA Maschinenbau GmbH.

### 2.2 Illustrations













All photos, figures and graphics contained in this document are for illustration and better understanding only and may differ from the current state of the product. Title photos and general views may also include optional components and special accessories.

## 3 Symbols

### 3.1 General Symbols

Symbol	Meaning
	Indicates passages within this operating manual that must be particularly observed in order to prevent malfunctions or damage to the lift table.
	Refers to chapters, sections, or figures within this document.
	Refers to an external document or a third-party source.

### 3.2 Symbols in Safety Instructions

Symbol	Safety Instruction
	General danger symbol, which requires the highest attention! <i>Failure to observe may result in damage to the equipment, serious injury or even death.</i>
	Warning of possible danger from forklift traffic! <i>Non-observance may result in life-threatening injuries.</i>
	Warning indicates a possible hazard under suspended loads! <i>Non-observance may result in life-threatening injuries.</i>
	Warning indicates a possible fall hazard! <i>Non-observance of these instructions may result in serious injuries.</i>
	Warning indicates a possible cutting hazard! <i>Risk of personal injury and possibly additional damage to equipment.</i>
	Reference to the obligation to wear protective gloves! <i>Non-observance of these instructions may result in personal injury.</i>
	Reference to the obligation to wear hearing protection! <i>Non-observance of these instructions may result in personal injury.</i>
	Reference to the obligation to wear protective goggles! <i>Non-observance of these instructions may result in personal injury.</i>
	Reference to the obligation to wear a respiratory protection mask! <i>Non-observance of these instructions may cause breathing difficulties and lung damage.</i>
	Reference to the obligation to wear safety shoes! <i>Non-observance of these instructions may result in personal injury.</i>
	Possible dangerous crushing hazard in the area of stationary objects! <i>Risk of personal injury and possibly additional equipment damage.</i>
	Reference to a possible crushing hazard! <i>Non-observance increases the risk of injury to hands and fingers!</i>
	This symbol warns of the dangers of electric voltage! <i>Failure to observe may result in damage to the equipment, serious injury or even death.</i>
	Fire hazard! Do not smoke and do not ignite open fire.
	Access for unauthorized persons prohibited! <i>Risk of personal injury and possibly additional equipment damage.</i>
	This safety notice indicates a possible dangerous pull-in hazard! Wearing loose clothing, jewellery as well as long untied hair is prohibited! <i>Risk of personal injury and possibly additional damage to property.</i>

## 4 General

This bandsaw machine was produced by HOKUBEMA Maschinenbau GmbH according to the current state of the art and placed on the market as a complete machine. All legal and normative regulations were observed.

### 4.1 Structure of the Machine

- Wheel diameter, cutting height, cutting width and blade speed vary depending on the model. The exact values for your machine can be found in the section ⇒ 6.2 “Technical Specifications”.
- The lower bandsaw wheel is driven by a three-phase motor and transmits the rotary motion to the bandsaw blade. The bandsaw wheels are provided with a wear and tear resistant lining of high durability.
- The upper bandsaw wheel is spring-mounted and can be adjusted via a hand wheel. This allows the machine to be optimally adjusted to the bandsaw blade.
- To guide the workpieces, a table fence is provided, which is mounted to the left of the saw blade.
- As protection against the saw blade and flying chips, the upper bandsaw guide is equipped with a guard.
- The control panel is used to start the bandsaw and to release the motor brake (depends on equipment).
- The height adjustment of the upper bandsaw guide and saw blade guard is done manually via a 3-arm lever (see section ⇒ 10.5).

### 4.2 Target Group and Previous Experience

This operating manual is intended for the operating and maintenance personnel of the machine. The operating personnel is to be determined by the operator and must further meet the following requirements:

- Basic technical knowledge (e.g. apprenticeship as carpenter, machine fitter, etc. and/or practice in operating woodworking machines)
- Reading and understanding these operating and maintenance instructions

In order to acquire the knowledge required to operate this machine, the operator must ensure the following measures:

- Product training for every operator (also possible external personnel)
- Regular safety instruction

### 4.3 Requirements for the Operators

- The bandsaw machine may only be operated by trained personnel who have also read this manual.
- Inspection, maintenance, cleaning and repair may only be performed by technical specialists with product-specific training and mechanical and/or electrical training.
- Specialists with product-specific training are to be commissioned and held responsible for planning and checking the work.
- The national protective regulations for employees must be observed .
- The operator is responsible for the safe use of the machine.
- The legal minimum age must be observed.

## 4.4 Accident Prevention

To avoid accidents, the following rules must be observed for operation:

- Prevent unauthorized persons from gaining access to the machine.
- Keep unauthorized persons away from the danger areas.
- Repeatedly inform present other persons about existing residual risks (see section ⇒ 5.1.4).
- Conduct and record regular training & instruction for persons who must be in the area of the machine.
- New employees must be trained internally to work on a thickener and this training must be documented.

## 4.5 General Safety Regulations

In general, the following safety regulations and obligations apply when handling the bandsaw machine:

- The bandsaw machine may only be operated in a technically perfect and clean condition.
- It is prohibited to remove, modify or bypass any protective, safety or monitoring equipment.
- It is forbidden to modify or alter the machine without the written approval of the manufacturer / supplier.
- Faults or damage must be reported to the operator immediately, eliminated without delay and repaired if necessary.
- For repairs, only original spare parts may be used.
- All protective, safety and monitoring devices must be regularly checked and maintained by the operator.
- Only instructed, trained or qualified persons may work on this machine.
- Maintenance work must be carried out and documented in accordance with the maintenance instructions.
- After maintenance or repair, the machine may only be started with all protective devices fitted. A responsible person must be defined for this purpose, who checks that the guards have been properly installed.
- For the operation of a bandsaw machine, the respective national safety regulations for employees as well as the national safety and accident prevention regulations apply.

## 4.6 Machine Description

The bandsaws of the “BSM” series are modern and spacious bandsaws suitable for cutting (cross-cutting and splitting) wood and similar materials. The tool is a toothed steel band to which the cutting movement is transmitted by two band rollers.

After switching on, the drive motor drives the lower flywheel. All operating elements as well as the emergency stop switch are easily accessible from the machine operator's workplace.

The machine operator transfers the cutting movement to the workpiece, either manually or by means of additional auxiliary or pushing devices. The adjustable guard reduces the risk of contact with the working tool.

## 4.7 About the “BSM” Series

Bandsaw machines of the “BSM” series are available in three different versions. They basically differ in their sizes and wheel diameters as well as in the possible cutting heights and cutting widths. This enables them to be individually adapted to different areas of application.

A torsion-free double-chamber welded construction forms the basis for all functional elements. Both safety doors are secured by safety switches and can only be opened after manual unlocking. The finely planed work table made of grey cast iron is generously dimensioned. It allows safe, precise and economical working.

The material fence is particularly stable and equipped with a practical quick-clamping device. The proven GL saw blade guide ensures optimum cutting results. Optionally, the machine can be equipped with the APA 2 precision bandsaw blade guide.

## 4.8 Standard Equipment

- Machine stand in torsion-free double-chamber welded steel construction
- Both doors are protected by safety switches
- Three-phase motors with different outputs from 1.1 to 2.2 kW<sup>1</sup>
- Finely planed machine table made of cast iron
- Swivelling table up to 45°
- Replaceable table insert
- Fence ruler can be used to the left and right of the saw blade, fence profile can be folded over
- Dynamically balanced bandsaw wheels with vulcanised rubber bandages, cambered for the use of narrow blades for curved cuts from 6 mm upwards
- Blade tension indicator with viewing window for setting the recommended tension
- With upper and lower bandsaw blade guide GL (type depends on model).  
Optional upper and lower precision bandsaw blade guides APA 2, Size 1 (BSM 7-40 / BSM 7-50) and Size 2 (BSM 7-60)
- Mechanical height adjustment of saw blade guard by hand wheel with locking pinion
- Integrated saw blade guard
- Scraper brush and chip catcher on the lower wheel
- BSM 7-40 / BSM 7-50: With push-button switch for start/stop and electrical motor brake
- BSM 7-60: With rotary cam switch for direct starting and mechanical motor brake
- Push stick with bracket on machine housing
- CE-compliant and GS-tested

## 4.9 Available Accessories

- Moving trolley with 2 swivel castors and 2 fixed castors
- Table extension and matching mounting rails
- APA band saw blade guide (top and bottom)
- Kreisfix for machining circular workpieces
- T-Slot in the table, including mitre fence
- Measuring scale on the table top

Suitable saw blades, special accessories and optional components can be found in chapter ⇒ 18.

In addition, you can order the saw blades and spare parts in our online shop [www.hokubema.com](http://www.hokubema.com).

---

<sup>1</sup> Depending on machine type

## 5 Safety

### 5.1 Basic Safety Instructions

Woodworking machines can be dangerous if used improperly. Therefore, observe the safety instructions listed in this chapter and the accident prevention regulations of your employer's liability insurance association!

	<p><b><i>The manufacturer accepts no liability for damage and malfunctions resulting from failure to observe these operating instructions.</i></b></p>
---	--

#### 5.1.1 Application Area and Intended Use

	<p><b><i>The WOODPECKER bandsaws are designed exclusively for cutting (coping and splitting) materials for which the respective bandsaw blade used is suitable (e.g. wood or other materials with the same physical and technical properties).</i></b></p> <p><b><i>This machine is not suitable for working on metal or scrap wood - which could contain nails, screws and other metal parts.</i></b></p> <p><b><i>The machine may only be operated on a level, firm surface with a sufficiently high minimum load corresponding to the weight of the machine (refer to section ⇒ 6.2).</i></b></p>
---	--

Other materials such as cork, rubber, hard plastics, bones, etc. can also be processed. Check whether the saw blade used is suitable for cutting these materials. Cutting these materials may require special safety measures, even if there is no obvious danger.

**Any processing of other materials requires prior consultation with the manufacturer and his approval.**

	<p><b><i>Improper use can lead to danger to persons and to a defect or damage to the machine.</i></b></p>
---	---

	<p><b><i>Only bandsaw blades recommended by the manufacturer are permitted.</i></b></p>
---	---

The machine is not suitable for operation outdoors or in potentially explosive environments.

- Permissible ambient temperature: - 15 ... +40° C
- Permissible humidity: 30 ... 90 %

Intended use also includes connecting the machine to an adequately dimensioned extraction system and observing the operating, maintenance and servicing conditions specified in the operating manual. Any other use is considered improper and is prohibited.

#### 5.1.2 Modifications and Conversions to the Machine

	<p><b><i>Unauthorised conversions and modifications to the machine are strictly prohibited for safety reasons. This will invalidate the CE declaration of conformity! The manufacturer is not liable for any resulting damage. The risk for this is borne exclusively by the operator/user.</i></b></p>
---	---





















#### 5.1.3 Connection to a Central Emergency Stop Switch





In workshops where the bandsaw is to be connected to a central emergency stop switch (e.g. school facilities), it should be noted that bandsaw models with electric motor brake are not suitable for this purpose. If an emergency release is triggered externally, the motor brake is no longer supplied with power. Therefore, the bandsaw blade continues to run unbraked until it comes to a standstill.



### 5.1.4 Residual Risks

The machine is built according to the latest state of the art and the recognised safety rules. Nevertheless, the use of the machine may cause danger to life and limb of the user or third parties or damage to the machine and other equipment. Due to the construction of the machine, the following residual risks can occur even when used as intended and despite compliance with all relevant safety regulations:

	Reading and applying the operating manual is mandatory for the operating personnel.
	Be alert to possible crushing hazards: a) when transporting the machine by forklift truck → between forks & pallet / machine b) when picking up the machine → between machine / pallet and floor c) when lowering the machine → between machine and fixed equipment
	Be alert to possible crushing hazards when lowering the machine (from the cargo pallet to the floor) with a forklift truck or overhead crane.
	Make sure that no objects fall from the forklift truck / crane. Do not leave any objects / tools on the machine.
	It is strictly prohibited to ride on the machine during a lifting operation (with the indoor crane or forklift). There is a danger of falling!
	Unauthorised persons are not allowed to enter the installation area of the machine (responsibility of the operator).
	Be aware of possible tripping and slipping hazards on the floor. Prevent possible hazards by keeping the floor dry and clean and by using anti-slip floor coverings around the machine.
	Be aware of the danger from falling objects such as workpieces, tools or similar. Therefore, wear safety shoes, especially when transporting and setting down the machine.
	Pay attention to the existing danger of being cut by the bandsaw blade. Never reach into the running bandsaw blade! Use pushing devices for short and thin workpieces. Wear protective gloves when changing the saw blade.
	Be aware of the danger of snow from chips and splinters and never remove them from the danger area by hand. Use suitable aids, e.g. hand brushes.
	Danger of cutting and drawing in! Do not clean the bandsaw blade or bandsaw roller with a brush or scraper held in your hand while the machine is running.
	Danger of cutting and drawing in! In case of a broken bandsaw blade or belt, wait until the machine has come to a complete standstill and only then open the separating safety device.
	Be aware of a possible danger of being drawn in by moving machine parts or tools. This can cause pieces of clothing or hair to be caught. Always wear tight-fitting clothing and a hair net if necessary. Generally avoid jewellery, loose clothing and untied long hair.
	Danger from electric shock! There are hazards when working on the electrical system. This work must only be carried out by qualified personnel!
	Danger from electric shock! It is strictly forbidden to bypass safety devices (e.g. safety switches).
	Electrical equipment must be maintained and cleaned regularly.
	Pay attention to the danger of crushing on workpiece guides and moving machine parts.
	Make sure that no unauthorised persons are in the area of the machine.
	Be aware of the risk of injury from flying tool parts in the event of tool breakage. Therefore wear protective goggles.
	Be aware of the risk of injury from flying workpiece parts and chips, splinters and dust coming out of the machine. Therefore wear protective goggles.

	Be aware of the increased noise emission and wear hearing protection.
	Be aware of the increased dust generation. Use the extraction system and wear a dust mask if necessary.
	The ON/OFF switch must always be freely accessible and not be concealed, e.g. with hopper boxes etc.
	Danger from ejecting parts (e.g. in case of tool breakage)! Avoid being in the danger zone to the right of the saw blade. A cracked bandsaw blade can dangerously fling out and cause the most serious injuries.
	Fire hazard due to wood dust in connection with flying sparks and/or open fire!

### 5.1.5 Observe the Environmental Protection Regulations

During all work with the machine, the environmental protection regulations, obligations and laws for waste avoidance and proper recycling and/or disposal applicable at the place of use must be observed. This applies in particular to installation, repair and maintenance work involving substances that could pollute the groundwater (e.g. hydraulic oils and cleaning agents and liquids containing solvents). In any case, prevent them from seeping into the ground or entering the sewage system.

	<p><b>Store and transport the above-mentioned hazardous substances only in suitable containers. Avoid leakage of hazardous substances by using suitable collection containers. Ensure that the above-mentioned substances are disposed of by a qualified disposal company.</b></p>
--	--

### 5.1.6 Organisational Measures

- ⚠ Always keep this operating manual within easy reach and at the place of use of the machine.
- ⚠ In addition to the operating manual, observe and instruct on generally applicable legal and other binding regulations for accident prevention and environmental protection.
- ⚠ Supplement the operating manual with further instructions, including supervisory and reporting duties, to take account of special operational features (e.g. with regard to work organisation, work processes, personnel employed).
- ⚠ Before starting work on the machine, the person responsible for its operation must have read the operating instructions, especially the chapter "Safety Instructions". This applies in particular to personnel who only occasionally work on the machine.
- ⚠ Check that work is carried out in a safety-conscious and hazard-conscious manner and in compliance with the operating manual.
- ⚠ Operators must not wear open long hair, loose clothing or jewellery (including rings). There is a risk of injury, e.g. by getting caught or drawn in.
- ⚠ Observe the safety instructions and danger warnings on the machine and keep them complete and in legible condition.
- ⚠ In case of safety-relevant changes to the machine or its operating behaviour, shut down the entire system immediately and report the fault to the responsible office/person.
- ⚠ Use personal protective equipment as necessary or required by regulations.
- ⚠ Do not make any modifications, additional attachments or conversions to the machine without the manufacturer's approval! This will compromise safety and invalidate the manufacturer's warranty and any liability claim. The same also applies to the installation and adjustment of safety devices and valves and to welding work on load-bearing part.
- ⚠ Spare parts must meet the technical requirements specified by the manufacturer. The exclusive use of original spare parts ensures this. Therefore, only use original spare parts from the manufacturer.
- ⚠ Observe the fire alarm and firefighting possibilities. Make the location and operation of fire extinguishers (fire class ABC) known. Do not use water!

### 5.1.7 Personnel Selection and Qualification - Basic Duties



- ⚠ The machine design and operation is intended for right-handers.
- ⚠ Work on and with the machine may only be carried out by reliable personnel. Observe the legal minimum age!
- ⚠ Only use trained or instructed personnel. Clearly define the responsibilities of the personnel for operating, setting up, maintaining and repairing!
- ⚠ Ensure that only authorised personnel work on the machine!
- ⚠ If personnel to be trained or apprenticed have to work on the machine, this may only be done under the constant supervision of an experienced resp. qualified person.
- ⚠ Work on the electrical equipment of the machine may only be carried out by a qualified electrician or by untrained persons under the direction and supervision of a qualified electrician in accordance with the electrotechnical regulations.

### 5.1.8 Training of Personnel













All machine operators must be adequately trained in the operation and maintenance of the machine. In particular, the training must include the following:

- ⚠ General rules for the use of the machine, proper operation, correct adjustment of the machine and the use of other accessories.
- ⚠ Proper handling of workpieces during the machining process. Correct position of the hands to the workpiece and to the bandsaw blade during and after machining.
- ⚠ The personnel must be informed about hazards, risks and appropriate protective measures.
- ⚠ The personnel must be trained in the area of regular checks of the guards and protective devices.
- ⚠ The personnel must be trained in the use of the guards and protective devices.







## 5.2 Safety Instructions for Specific Phases of Operation

	<b><i>Defects and damage to the machine are to be reported immediately after detection.</i></b>
	<b><i>Any mode of operation that compromises safety is prohibited!</i></b>
	<b><i>Sufficient lighting (at least 500 lux) around the machine must be ensured!</i></b>

### 5.2.1 Before starting Work

-  Only use sharp, crack-free and sufficiently set bandsaw blades.
-  Check that the saw blade is correctly aligned on the bandsaw roll.
-  Check bandsaw guide for correct adjustment (back roller, lateral guide rollers).
-  Adjust saw blade guard to workpiece height.
-  Make sure that the cut for the saw blade in the table insert is as narrow as possible.
-  Keep the necessary aids (e.g. table fence, push stick, push-block, support bracket etc.) ready and use them if necessary.
-  Keep the floor in the movement area around the machine free of tripping hazards.
-  Provide containers for waste.
-  Wear close-fitting clothing.
-  Wear safety shoes and ear protection.
-  Wear protective gloves when changing the bandsaw blade.
-  If gloves are required when handling workpieces, they must be fingerless.

### 5.2.2 Normal Operation

-  **Guards:** Take measures to ensure that the machine can only be operated in a safe and functional condition. Only operate the machine when all guards and safety-related devices such as
  - detachable guards,
  - noise insulations,
  - extraction system
 are available and functional.
-  **Workpiece:** Before the operation, check the workpiece for
  - foreign inclusions
  - knots
  - twists (contortions) and other irregularities.
-  **Machine condition:** Check the machine for externally visible damage and defects at least once per shift! Any changes that have occurred (including those in the operating behaviour) must be reported immediately to the responsible office or person! If necessary, stop and secure the machine immediately!
-  **Extraction:** The machine must be connected to an effective extraction system. This requires a flow velocity of at least 20 m/s for dry chips and 28 m/s for moist chips (moist 18% or more).
-  **Work area:** An obstacle-free work area around the machine is essential for safe operation. The floor should be level, well maintained and free from debris such as chips and cut-off workpieces.
-  **Cutting area during operation:** Never try to remove splinters, chips or other parts from the cutting area while the machine is running! Never remove splinters and chips by hand!

- ⚠ **Special tools:** For certain operating phases and operations it is necessary to use special tools for workpiece feeding (e.g. table fence, push stick, push-block, support bracket etc.).
  - When cutting upright workpieces, secure them against tilting, e.g. by means of a stop bracket, table fence, push-block.
  - Secure round workpieces with wedge support or similar against twisting.
  - For very short or narrow workpieces use a suitable pushing device.
  - Ensure good workpiece support for long or wide workpieces, e.g. with a table extension.
  - Do not machine unshaped workpieces that do not fit on the machine table.
- ⚠ **Work interruptions:** Switch off the machine even during short interruptions! Never leave the machine running unattended!
- ⚠ **When the work is finished:** Release the saw blade tension and provide the machine with a warning sign. Lower the saw blade guard to table height.
- ⚠ **Leaving the machine:** Switch off the control voltage and main switch before leaving the machine. Never leave the machine unattended in an unsecured state.
- ⚠ **Behaviour in the event of a saw blade breakage:** Be sure to wait until all bandsaw wheels have come to a complete standstill before taking any further action. Only the lower wheel is equipped with a brake!

### 5.2.3 Special work within the Scope of Maintenance Work as well as Troubleshooting in the Workflow

- ⚠ Observe maintenance and inspection activities prescribed in the operating manual!
- ⚠ These activities, as well as all other repair work, may only be carried out by qualified personnel!
- ⚠ For all work concerning operation, production adjustment, conversion or setting of the machine and its safety-related equipment as well as maintenance and repair, observe switch-on and switch-off procedures according to the operating manual and instructions for maintenance work!
- ⚠ Secure the machine against unexpected restarting during maintenance and repair work.
- ⚠ Always tighten screw connections that have been loosened during maintenance and repair work!
- ⚠ If it is necessary to dismantle safety equipment during set-up, maintenance and repair, the safety equipment must be reassembled and checked immediately after completion of the maintenance and repair work!
- ⚠ Ensure safe and environmentally friendly disposal of operating and auxiliary materials (e.g. oils) and replacement parts (e.g. electronic components)! Refer to chapter ⇒ 17 “Disassembly and Scrapping”.

## 5.2.4 Safe Work Practices



- ⚠ Wear personal protective equipment (safety goggles, safety shoes, hearing protection, dust mask).
- ⚠ Whenever possible, a push stick or a comparable aid must be used to feed the workpiece. It is essential to avoid working with the hands near the saw blade.
- ⚠ When cutting narrow workpieces, generally use a push stick.
- ⚠ Use aids such as auxiliary fence and push handle for concealed cuts.
- ⚠ Use an aluminium profile rail with a narrow contact edge for cutting narrow and low laths.
- ⚠ Always work with all protective devices! These must be in the intended places and in perfect working order. Defective guards must be replaced immediately.
- ⚠ Damaged table inserts are to be replaced with new ones.
- ⚠ Regular maintenance and cleaning of bandsaw blades, extraction system, etc. is required to reduce noise.
- ⚠ Refit removed guards in accordance with the manufacturer's instructions.
- ⚠ Never clean the bandsaw blade or bandsaw wheels with a hand-held brush or scraper while the bandsaw blade is in motion.
- ⚠ Do not start cutting until the bandsaw blade has reached full speed.
- ⚠ Do not use damaged bandsaw blades.
- ⚠ Check the bandsaw blades regularly for damage.
- ⚠ Replace damaged bandsaw blades immediately.
- ⚠ Only use bandsaw blades suitable for the operation and the material to be processed.
- ⚠ Do not exceed the permissible speed of the bandsaw blade.
- ⚠ Do not use damaged tools.
- ⚠ Damaged parts must be replaced with new ones.
- ⚠ Repairs may only be carried out by qualified personnel with the main switch locked.
- ⚠ The machine is equipped with an automatic motor brake. If the brake no longer brakes within the prescribed braking time (10 s) despite readjustment, the customer service must be informed.

## 5.2.5 Safety Equipment

The machine is equipped with the following necessary safety devices:

- Complete protection of the saw blade along its entire length.
- The saw blade guard is manually height-adjustable and covers the saw blade from all four sides, preventing hands from entering the danger zone.
- When the doors are opened, the power supply to the motor is automatically interrupted.
- Additional safety switches prevent unintentional opening of the doors. In order to be able to open the doors during a belt or wheel change, the safety switches must first be manually unlocked (see section ⇒ 10.2).
- The bandsaw guide is equipped with a transparent protective cover to ensure a clear view of the cutting area for the operating personnel. At the same time it partly serves as splinter protection.
- The standard version of the bandsaw machine is equipped with an automatic motor brake that brings the saw blade to a standstill within 10 seconds in the event of a power interruption.
- The blade tension indicator shows the correct tension of the blade in relation to its width.

## 5.2.6 Noise

Certain instructions must be followed to avoid an increase in the noise level:

- Sawdust falling between the wheel and the saw blade can cause vibrations that can increase the noise level.
- Only original saw blades with a correct and clean weld must be used.
- The saw blade must be correctly adjusted for the intended work and suitable for the material.
- The instructions for the wheel surfaces (section ⇒ 16.4) and the saw blade (see section ⇒ 16.5) must be followed to keep the parts in good condition and reduce the noise level.

## 5.3 Danger Zones on the Bandsaw

### 5.3.1 Danger Zone Bandsaw Blade

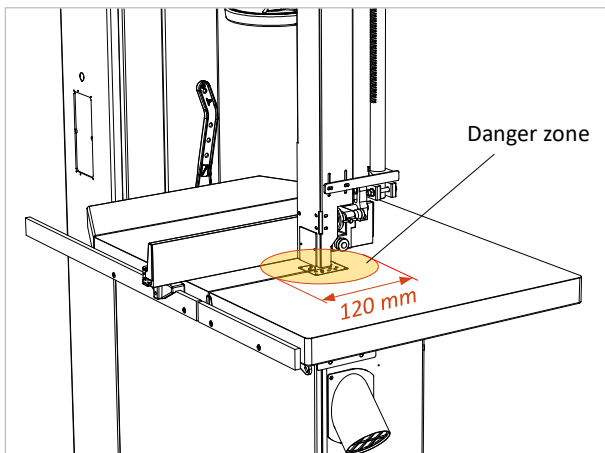

Figure 2: Danger zone saw blade

- The area 120 mm around the saw blade is a danger zone.
- Make sure that your hands are at least 10 cm away from the saw blade.
- If a minimum distance of 10 cm cannot be maintained, use a push stick or other suitable aid for feeding the workpiece.
- When feeding the workpiece, place your hands flat with your thumbs on them and do not spread your fingers.
- Lower the guard to a distance of max. 5 mm from the workpiece.

	<p><b><i>Danger of cutting and being drawn in! Danger zone of 120 mm around the saw blade!</i></b></p>
--	--

### 5.3.2 Danger Zone around the Machine

Another danger zone is located to the right of the machine. Here there is a particular risk of serious injury from a torn bandsaw blade, which can be ejected in this area. During operation, it is strictly forbidden for the operator as well as any helpers and possible observers to stay in this area!

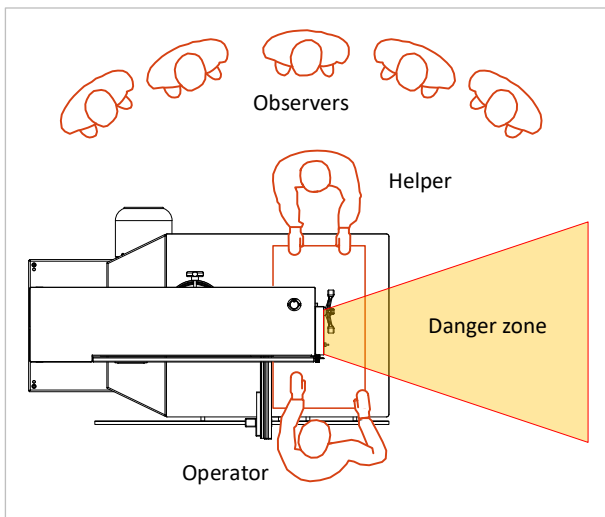

Figure 3: Danger zone around the machine

- The operator of the machine must generally stand in the direction of cutting, in front of the bandsaw and outside the danger zone.
- A required helper for workpiece removal must generally stand opposite the cutting direction and outside the danger zone, behind the machine, on the opposite side to the operator.
- Any observers must stand in a semicircle outside the danger zone. An adequate distance must be kept so that the operator of the machine and a possible helper are not hindered in their work.

	<p><b><i>Be aware of the danger posed by an ejecting bandsaw blade in the event of a band break! Entering the danger zone during operation can lead to very serious injuries.</i></b></p>
--	---

	<p><b><i>Only use bandsaw blades that are in perfect condition resp. have been correctly welded, ground and set. Damaged bandsaw blades must be replaced immediately.</i></b></p>
--	---

## 6 Machine Data

### 6.1 Series and Expandability

#### Nameplate:

 <b>WOODPECKER</b> HOKUBEMA GmbH • D-72488 Sigmaringen Telefon/phone +49(0)7571 755-0	
<b>Bandsägemaschine</b> 	
Baureihe line	<input type="text"/>
Typ type	<input type="text"/>
Maschinen-Nr. machine no.	<input type="text"/>
Baujahr year of construction	202
Bemessungsspannung U = nominal voltage U =	<input type="text"/> V
Frequenz/Phasenzahl frequency/phases	Hz / 3
Stromart kind of current	AC
Volllaststrom I = operating current I =	<input type="text"/> A
Überstromschutz, intern excess current protection, internal	<input type="text"/> A
<input type="text"/>	
<input type="text"/>	

Figure 4: Nameplate

<p><b>HOKUBEMA Maschinenbau GmbH</b>                  Graf-Stauffenberg-Kaserne                  Binger Str. 28   Halle 120                  DE-72488 Sigmaringen (Germany)                  Tel.: +49 (0) 7571 / 755-0                  Fax: +49 (0) 7571 / 755-2 22</p>
---

#### Series:



Figure 5: Bandsaw series BSM

#### Expandability:

The machine is designed for the later expansion of optional accessories (see chapter ⇨ 18) from the extensive manufacturer's range. If you wish to expand your machine at a later date, please ask us for documentation on the desired accessories.

Please indicate the following data:

1. **Type**
2. **Machine-No.**
3. **Voltage (V)**
4. **Power (kW)**
5. **Year of manufacture**



## 6.2 Technical Specifications

<b>Position</b>	<b>Unit</b>	<b>BSM 7-40</b>	<b>BSM 7-50</b>	<b>BSM 7-60</b>
Bandsaw wheels $\varnothing$	mm	400	500	600
Main motor	kW	1.1	1.5	2.2
	HP	1.5	2	3
Motor brake	-	electrical	electrical	mechanical
Nominal saw blade speed	m/min	1400	1300	1550
Max. cutting height (GL)	mm	190	325	400
Max. cutting height (APA)	mm	205	330	400
Max. cutting width	mm	385	480	580
Max. saw blade length	mm	3330	4140	4735
Min. saw blade length	mm	3230	4060	4660
Saw blade thickness	mm	0.4	0.4 - 0.5	0.5 - 0.6
Wheel surface width	mm	25	30	30
Max. saw blade width (GL)	mm	20	30	35
Min. saw blade width (GL)	mm	15	15	15
Max. saw blade width (APA)	mm	20	25	30
Min. saw blade width (APA)	mm	15	15	15
Size of the saw blade guide	-	1	1	2
Table dimensions	mm	420 x 570	500 x 680	590 x 810
Weight	kg	130	220	280

## 6.3 Dimensions

Height x length x width x table height in mm:

<b>BSM</b>	<b>H</b>	<b>L</b>	<b>W</b>	<b>T</b>
<b>7-40</b>	1740	760	490	900
<b>7-50</b>	1930	930	550	900
<b>7-60</b>	2120	1130	640	920

*Dimensions and construction subject to change*

### Space requirement:

The effective space requirement usually depends on the dimensions of the machine and the dimensions of the workpieces to be processed. In general, provide sufficient space around the machine and also calculate the required workplace for the operating personnel and for the infeed and outfeed of the workpieces.

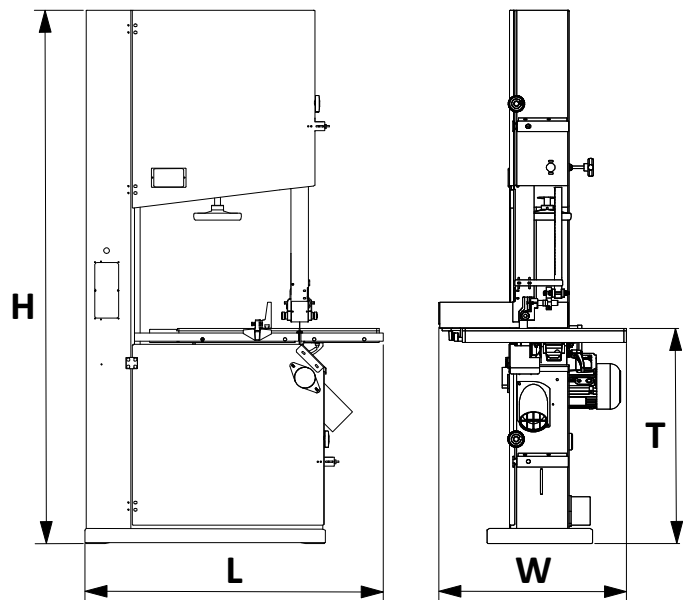

Figure 6: Dimensions

## 6.4 Emission Levels according to EN ISO 3746:2010

### 6.4.1 Noise Information

The values given are emission levels and therefore do not necessarily represent safe workplace values. Although there is a correlation between emission and immission levels, it cannot be reliably deduced whether additional precautionary measures are necessary or not.

Factors that may affect the current immission level at the workplace include the duration of exposure, the nature of the workspace, other noise sources, etc., e.g. the number of machines and other activities in the vicinity. The permissible workplace values can also vary from country to country.

However, this information should enable the user to make a better assessment of hazard and risk.

### 6.4.2 Noise Emission Values

		<i>BSM 7-40</i>	<i>BSM 7-50</i>	<i>BSM 7-60</i>
<b>Noise level</b>				
Idle	dB(A)	80	80	80
Working	dB(A)	102	102	102
<b>Emission pressure level at the workplace</b>				
Idle	dB(A)	67	67	67
Working	dB(A)	89	89	89

**Note:** When checking the accuracy of the specified emission values, the measurements must be carried out using the same measurement method and the same operating conditions as those specified.

Uncertainty allowance **K = 4 dB(A)**.

	<p><b>The workplace-related noise emission values of the machine exceed 85 dB(A)! Therefore, suitable hearing protection must be provided to the personnel!</b></p>
---	---

**Note:** Regular maintenance and cleaning of the bandsaw blade and extraction system as well as lubrication of the bandsaw blade guides (back and side rollers, see section ⇒ 16.2) generally has a positive effect on the machine's noise level.

### 6.4.3 Dust Emission according to GS-HO-05 in mg/m<sup>3</sup> air

(permissible max. 2.0 mg/m<sup>3</sup> air)

	<i>BSM 7-40</i>	<i>BSM 7-50</i>	<i>BSM 7-60</i>
At the workplace	0.23	0.44	0.74

### 6.4.4 Extraction

		<i>BSM 7-40</i>	<i>BSM 7-50</i>	<i>BSM 7-60</i>
Number of suction nozzles	pcs.	2	2	2
Suction nozzle Ø	mm	100	100	100
Stat. negative pressure top/bottom	Pa	800 / 700	720 / 680	640 / 620
Volume flow	m <sup>3</sup> /h	790	790	790

To ensure that the chips extracted at the point of origin and the dust are transported on to the collection system, the conveying speed of the extracted air must be 20 m/s for dry chips and 28 m/s for moist chips (moisture 18% or more).

## 7 Installation and Connection

### 7.1 Check Delivery Conditions

Check the consignment for completeness and possible transport damage. In case of transport damage, please keep the packaging and inform the shipping company and the manufacturer immediately! Later complaints cannot be accepted.

### 7.2 Transport to the Installation Site

#### 7.2.1 Transport

- The machine is delivered upright bolted on a transport pallet.
- The centre of gravity of the machine is approx. in the middle of the pallet.
- Move between the pallet with a lift truck (see ⇒ Figure 7) and lift the machine only a few centimetres and move it to the installation site.
- Then remove the transport timbers, transport bolts and the lashing eye attached to the machine column.
- Now remove the machine from the pallet with a crane or similar suitable lifting equipment and place it at the place of use.
- Then follow the instructions in section ⇒ 7.3.

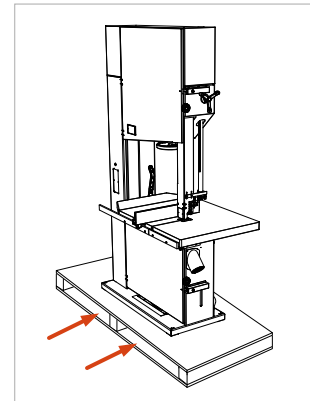

Figure 7: Transport

	<b>Danger of tipping over during transport!</b>
--	---

### 7.3 Installing the Machine

The machine must be placed level on the floor. To do this, level the machine with a spirit level using the 4 grub screws in the machine base. There are four additional holes at the bottom of the machine base, which can be used to secure the machine against tipping with screws. However, these locking screws must not be tightened, as otherwise the machine may be damaged by vibrations occurring.

- A foundation is not required. The floor must have a load-bearing capacity corresponding to the machine weight (see “Technical Specifications” in section ⇒ 6.2).
- The bare parts of the machine are greased to protect them from corrosion. Carefully degrease the parts protected against rust with petroleum or benzene.

	<b>Be aware of possible crushing hazards when placing the machine (from the pallet to the floor) by means of a forklift truck or overhead crane. Pay particular attention to your hands and feet and wear safety shoes and protective gloves as a precaution.</b>
--	---

	<b>Danger to life when using a forklift truck! Keep a sufficient distance from the forklift truck and watch its speed. Vehicles with combustion engines also produce toxic exhaust gases. Wear a breathing mask if necessary.</b>
--	---

	<b>It is essential that the machine is level! Check with spirit level!</b>
--	--

	<b>Dispose of the packaging material in an environmentally friendly way!</b>
--	--

	<b>Do not use nitro thinner for cleaning. Painted surfaces of the machine can be damaged.</b>
--	---

	<b>Fire hazard! Do not smoke and do not light an open fire.</b>
--	---

## 7.4 Temporary Storage

If the machine is not put into operation immediately after delivery, it must be stored carefully in a protected place. Carefully cover the entire machine so that neither dust nor moisture can penetrate. The bare, non-surface-treated parts (e.g. the cast iron tabletop) are provided with a preservative. This must be checked regularly for effectiveness and renewed if necessary.

## 7.5 Lashing on a Transport Vehicle

**The responsibility for safe loading is borne by the respective shipper!**



**A separate lashing strap must be used for each lashing point. Every lashing point must be tensioned individually on the loading area of the vehicle! The pallet must also be secured against slipping!**

Please note the following when lashing in the transport vehicle:

- The loading area of the transport vehicle must always be clean and dry.
- The lashing straps used must be suitable for the total weight of the machine (see section ⇒ 6.2).
- Fastening on the loading area is done by lashing down: This means that the transport pallet is secured by frictional locking. The load is pressed so firmly onto the loading surface that it can no longer slip. The clamping tool should have a high STF value at the frictional connection, e.g. long-lever ratchets.
- In addition, anti-slip mats should be used to provide even more safety.
- The ideal lashing angle ( $\alpha$ ) for tie-down lashing is 83° to and 90°. Therefore, the lashing straps should pull downwards approx. vertically. As the angle decreases, the pretensioning force of the lashing is reduced.
- Observe the permissible total weight of the transport vehicle.
- Ensure that the permissible axle loads of the transport vehicle are observed. The load must be distributed evenly on all axles of the vehicle.

### 7.5.1 Lashing the Bandsaw

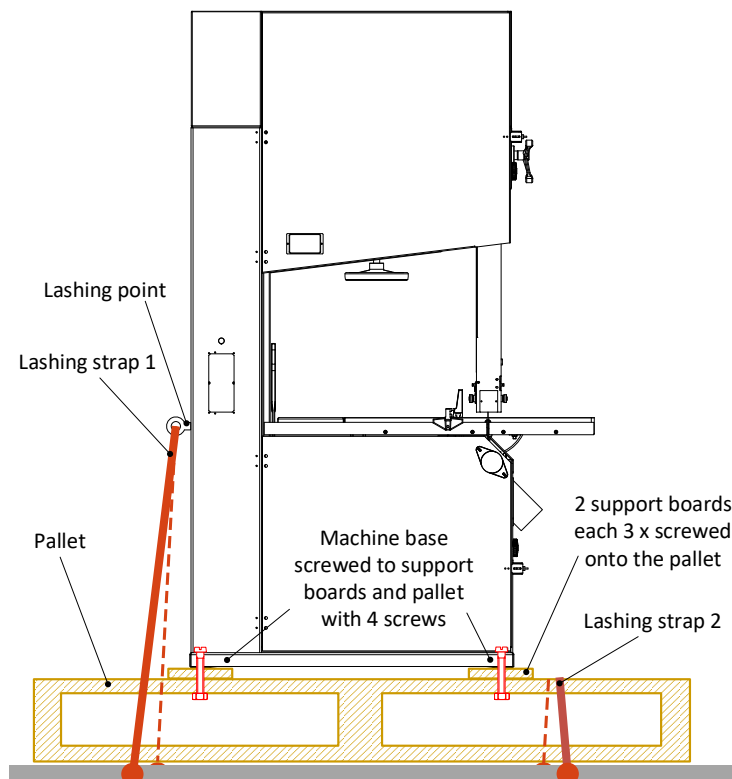

Figure 8: Lashing the bandsaw for transport

- Additionally secure the machine against tipping over!

- For transport in a transport vehicle, the machine must be bolted upright on a pallet and braced with 2 lashing straps on the loading area.
- For this, there is a lashing point for lashing strap 1 on the left machine column (see ⇒ Figure 8). The pallet is directly lashed with lashing strap 2.
- Screw two support boards between the pallet and the machine base to the pallet with at least 3 screws<sup>2</sup> each.
- The machine must then be screwed<sup>4</sup> to the support boards and the pallet via the 4 holes in the machine base.
- An anti-slip mat between pallet and loading area of the vehicle provides additional safety.
- Additionally secure the machine against tipping over.

<sup>2</sup> Generally use sturdy screws of sufficient length and diameter to match the hole! Hexagonal screws with matching nuts and large washers on both sides are best suited.

## 7.6 Connecting the Extraction Unit

- The machine must be connected to an effective extraction system on-site. Two suction nozzles are available for this purpose.
- You will find the diameter of the suction nozzles (A) of your machine in the technical specifications (⇒ 6.2).
- All parts of the extraction system, including hoses, must be included in the earthing measure.

	<p><b>When flexible suction hoses are used, they must be flame-retardant.</b></p>
--	---

	<p><b>When the machine is switched on, the extraction system must start automatically.</b></p>
--	--

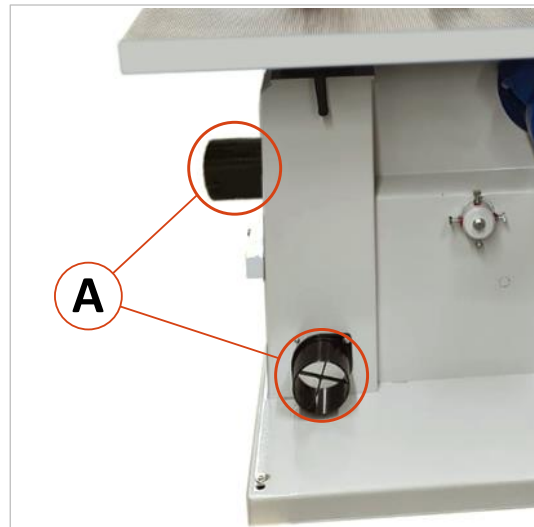

Figure 9: Suction nozzles

On some models, 2 signal transmitter lines can be connected to the terminals of the contactor for automatic switching of the extraction system:

Model	BSM 7-40	BSM 7-50	BSM 7-60
Connection terminals	unavailable	unavailable	1 + 2 of rotary cam switch S2

### Installation only by a qualified electrician!

The air speed must be set in such a way that, with the extraction line connected and the tools stationary, an average air speed of

- 20 m/s (1450 m<sup>3</sup>/h) for dry chips,
- 28 m/s (2050 m<sup>3</sup>/h) with moist chips (moisture 18 % or more)

is achieved at the extraction nozzles.

The required air volume for extraction is 1000 m<sup>3</sup>/h.

If the machine is properly connected to the extraction system, it can be assumed that the wood dust assessment value will be complied with (permanently and safely).

	<ul style="list-style-type: none"> <li>• <b>The air velocity must be checked before initial commissioning and after significant changes.</b></li> <li>• <b>The extraction system must be checked daily for obvious defects after initial commissioning and monthly for effectiveness.</b></li> </ul>
--	--

At certain intervals (or depending on the frequency of use) it is necessary to clean the inside of the machine from sawdust. When operating in closed rooms, an external chip and dust extraction system must be connected.

## 7.7 Electrical Connections

	<p><b>The connection must be carried out by an authorised electrician!</b></p>
--	--

The circuit diagrams are located behind the main control panel.

**Please observe the specified nominal voltage 400 VAC / 50 Hz (3 phases / N / PE)!**

- Ensure that the motor voltage (as indicated on the motor plate) matches the mains voltage.
- The supply cable is inserted through the cable gland at the bottom of the terminal box. Recommended cable type: H07RN (WDE0282), whereby additional measures must be taken to protect against mechanical damage.
- The connection to the mains (3 phases) is made at the terminal strip in the terminal box or optionally in the control cabinet. The 3 phases must be connected to the terminals “L1”, “L2”, and “L3”.
- The protective earth wire (yellow/green) must be connected to the terminal marked “PE”.
- Then close the cable gland again so that it is dust-tight.

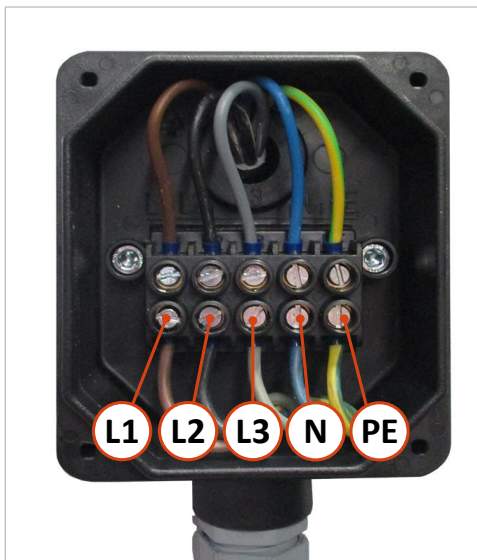

Figure 10: Connections in the terminal box

The wire cross-section as well as the back-up fuse depend on the bandsaw model and the motor power:

Motor Power	Fuse	Cross-section mm <sup>2</sup>
BMS 7-40	16 A	The wire cross section must be determined on site by a qualified electrician!
BMS 7-50	16 A	
BMS 7-60	16 A	

**Important:** Also check the correct running direction of the bandsaw blade (saw blade teeth must run downwards).

	<p><b>If the running direction is incorrect, two phases in the control cabinet must be reversed.</b></p>
--	--

	<p><b>The fault loop impedance and the suitability of the overcurrent protection device must be checked at the installation site of the machine.</b></p>
--	--

The electrical wiring and connection must be carried out by a specialist in accordance with the applicable local EVU, VDE and EN regulations.

**Please note:**

Only if the connection is carried out by an authorised electrician can a guarantee be given for the motor. In the event of a complaint, the electrician must confirm in writing that he has connected the machine in accordance with the regulations.

## 8 Components and Controls

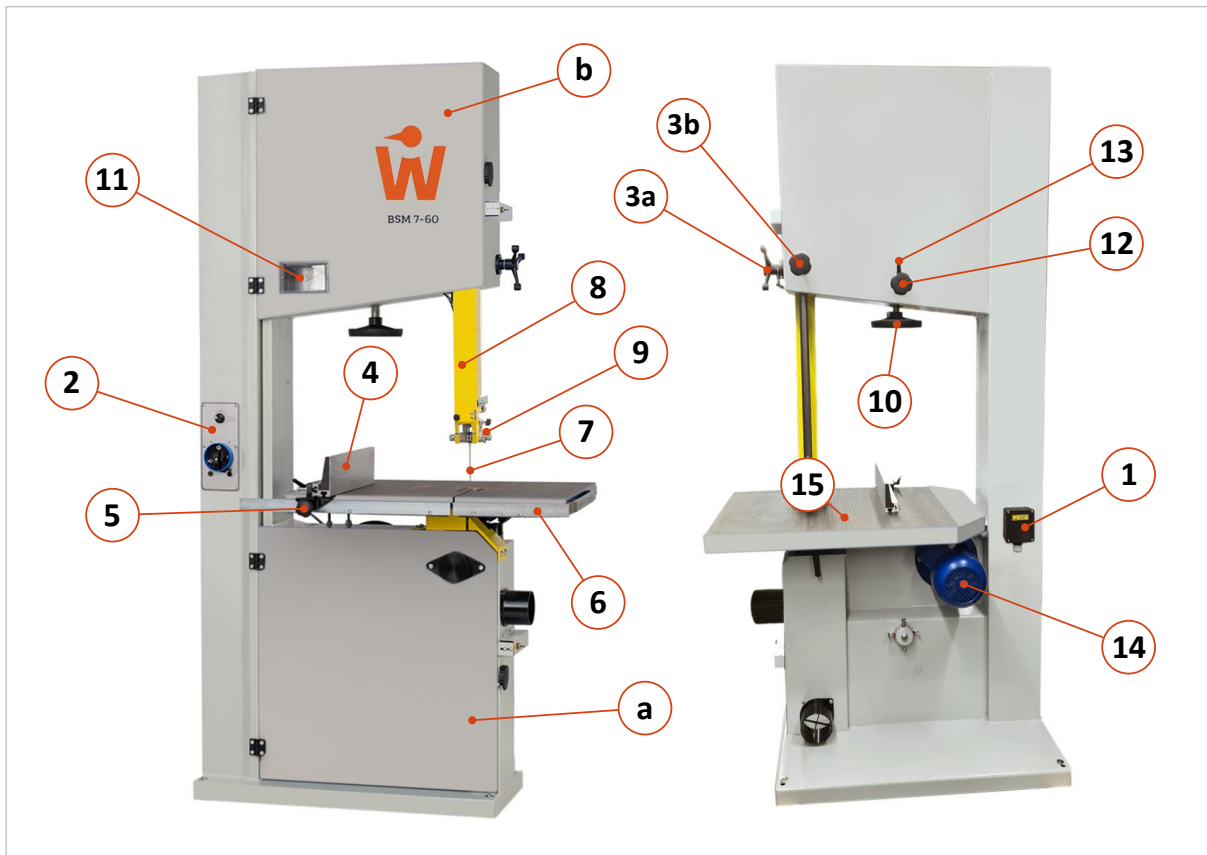



Figure 11: Components and controls

<b>Pos.</b>	<b>Description</b>	<b>Pos.</b>	<b>Description</b>
<b>1</b>	Terminal box	<b>9</b>	APA bandsaw guide
<b>2</b>	Control panel (equipment see ⇒ 9.1)	<b>10</b>	Adjusting wheel for saw blade tension
<b>3a</b>	Height adjustment lever (upper saw blade guide)	<b>11</b>	Indicator for saw blade tension
<b>3b</b>	Clamping wheel for height adjustment lever (3a)	<b>12</b>	Wheel for upper wheel inclination
<b>4</b>	Rip fence	<b>13</b>	Clamping lever for adjusting wheel (12)
<b>5</b>	Rip fence clamping	<b>14</b>	Drive motor
<b>6</b>	Rip fence guide	<b>15</b>	Machine table with table insert
<b>7</b>	Bandsaw blade	<b>a</b>	Cover for drive wheel (bottom)
<b>8</b>	Saw blade guard	<b>b</b>	Cover for upper wheel

## 9 Commissioning

Read the operating manual and the chapter ⇒ 5 “Safety” carefully before commissioning and observe them.

	<p><b>Before switching on, check that</b></p> <ul style="list-style-type: none"> <li>• the floor around the machine is clean and free of interfering parts and workpieces,</li> <li>• there are no loose parts on the machine table and all tools have been removed,</li> <li>• the bandsaw blade is well ground and correctly positioned on the guide rollers,</li> <li>• there are no objects in the bandsaw wheels,</li> <li>• the safety guards are fitted according to regulations,</li> <li>• the extraction system is connected and in good working order,</li> <li>• the saw blade tension is correctly adjusted,</li> <li>• the V-belts are tensioned</li> <li>• and no persons are in a danger zone of the machine.</li> </ul>
---	--

### 9.1 Switching ON and OFF

#### 9.1.1 BSM 7-40 and BSM 7-50

**Remark:** The machine is equipped with an electronic brake that does not need to be released.

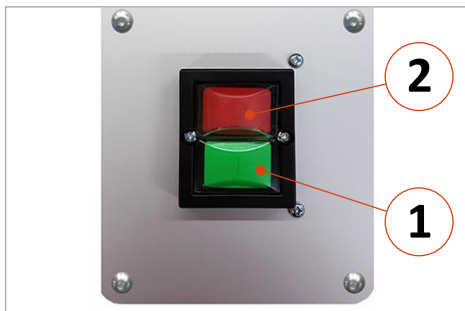

Figure 12: Push-buttons

- Check saw blade tension (tighten if necessary).
- Make sure that there are no objects on the machine, the doors are closed and the safety switches (refer to section ⇒ 10.2) are locked.

**Switching ON:**

- Press button (1) and wait until the bandsaw has reached its full speed.

**Switching OFF:**

- Press button (2) → Machine is braked.

#### 9.1.2 BSM 7-60

**Remark:** The machine is equipped with a mechanical brake and a brake release switch.

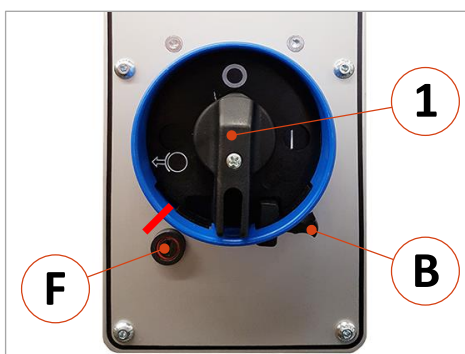

Figure 13: Rotary switch with locking latch

- Check saw blade tension (tighten if necessary).
- Make sure that there are no objects on the machine, the doors are closed and the safety switches (refer to section ⇒ 10.2) are locked.

**Switching ON:**

- Turn rotary switch (1) to position “I”.

**Switching OFF:**

- Turn rotary switch (1) to position “O” → Machine is braked.

**Release the brake:**

- Turn rotary switch (1) to position “O”.
- Turn the locking latch (B) to the left (see red marked position in ⇒ Figure 13).
- Turn the rotary switch (1) all the way to the left → Brake is released (dwell time = 10 s).



## 9.2 Frequent switching ON and OFF in succession

Avoid switching on and off several times in quick succession, as a bandsaw machine is not designed to be switched on and off constantly. This may cause an overload, which will trip the fuses or the motor protection device. On the BSM 7-60 model with mechanical motor brake and high flywheel mass, frequent switching on and off can also cause damage to the motor brake. The mechanical motor brake of the bandsaw is designed for a maximum of 10 braking operations per hour.

	<p><b>Switching on and off several times in short intervals can cause damage to the machine and/or the motor brake.</b></p>
---	---

# 10 Settings and Operation

## 10.1 Basic Factory Setting

The machine is precisely adjusted and extensively tested before delivery. The bandsaw wheels are adjusted at the factory using the adjustment points (J) provided on the machine, see ⇒ Figure on the right.

	<p><b>The adjusting screws at the adjustment points (J) must not be manipulated under any circumstances. Otherwise the bandsaw wheels will no longer be correctly aligned with each other. This can cause the bandsaw blade to break.</b></p>
---	---

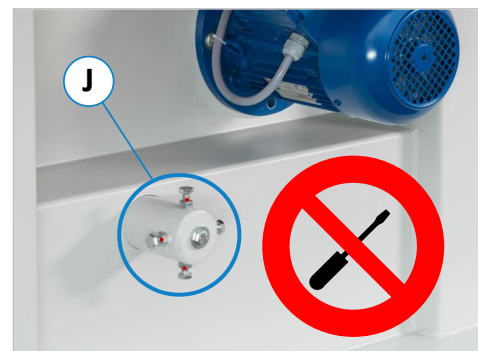

Figure 14: Factory adjustment points

Adjustment of the adjustment points (J) is reserved exclusively for HOKUBEMA Maschinenbau GmbH factory technicians! In case of doubt or problems with the machine, please contact our customer service department.

**Note:** The adjustment screws are also protected against unauthorised opening with a red lacquer. If the screws are nevertheless adjusted without authorisation, any guarantee for the repair of the resulting damage is invalidated in this respect.

## 10.2 Door Interlock with Safety Switches

To prevent unintentional door opening during operation and the associated dangers, the machine is equipped with a safety switch on each <sup>3</sup> of the two doors.

	<p><b>The doors of the bandsaw can only be opened if the safety switches have been unlocked with the knurled screws (R) beforehand. To be able to restart the machine afterwards, the safety switches must be locked again.</b></p>
--	---

### Unlock:

To open the door, the knurled screw (R) on the respective safety switch must be turned fully clockwise up to the stop so that the threaded pin (G) protrudes completely from the housing of the switch.

→ The door is unlocked and can be opened.

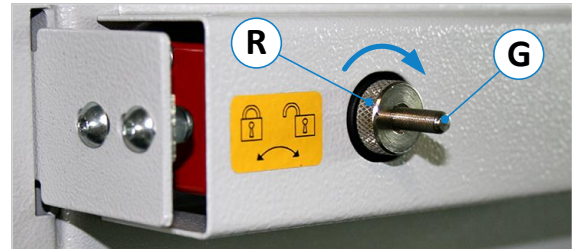

Figure 15: Safety switch - door unlocked

### Lock:

After changing the bandsaw blade, the door must be closed and locked again. To do this, turn the knurled screw (R) on the safety switch fully counter-clockwise until the grub screw (G) disappears completely into the knurled nut again.

→ Only then can the machine be started again.



Figure 16: Safety switch - door locked

<sup>3</sup> The version BSM 7-40 has only one safety switch that secures both doors simultaneously.

### 10.3 Inserting and Tensioning a Bandsaw Blade

To ensure safe working without incidents, the bandsaw blade must be placed and adjusted properly. For wide blades, at least two persons are required for this purpose.

 	<p><b>Caution: Danger of cutting! Put on protective gloves when changing the bandsaw blade!</b></p>
---	---

- Switch off the machine, disconnect it from the power supply and secure it.
- Unlock the safety switches for the doors (a) and (b) according to section ⇨ 10.2.

	<p><b>The doors of the bandsaw can only be opened if the safety switches have been unlocked beforehand with the knurled screws (R), see section ⇨ 10.2. Before the machine can be started again, the safety switches must first be locked.</b></p>
---	--

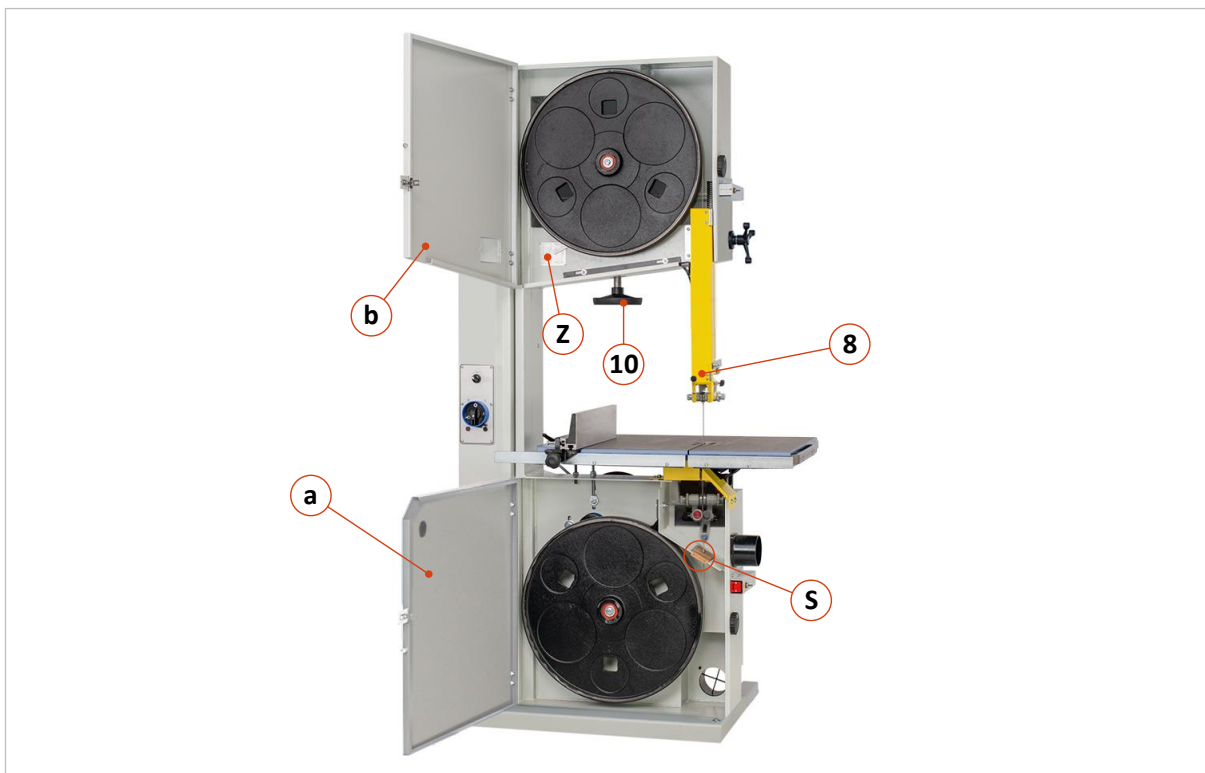



Figure 17: Overview - Inserting and tensioning the bandsaw blade

- Open both doors (a) and (b) and the blade guard (8).
- Remove chip catcher (S) by pulling it out.
- Loosen the handwheel (10) for the band tension and remove the old bandsaw blade if necessary.
- Place the new blade on the wheels (teeth pointing outwards) and pretension slightly via handwheel (10).
- Reconnect the machine to the power supply.
- Only for version BSM 7-60 with mechanical motor brake → Turn brake release switch to position “active”.
- Now check by turning manually whether the saw blade runs cleanly and centrally and align if necessary.
- Set the final saw blade tension with the handwheel (10) and the pointer (Z) of the blade tension indicator.

	<p><b>The blade tension is indicated by the pointer (Z). The blade must be tensioned until the pointer points to the line that corresponds to the indicated blade width.</b> Example 30 mm blade → The pointer (Z) must point to the line belonging to No. 30.</p>
---	--

- Push the chip catcher (S) back in and close the blade guard (8).
- Close the doors again, lock the safety switch and switch off the brake release switch if necessary.
- Switch on bandsaw blade and start test run.

## 10.4 Adjusting the upper Bandsaw Wheel

The wheel adjustment controls are located at the top of the rear of the machine (see ⇨ Figure 18).  
By turning the bandsaw wheel by hand, the position of the blade can be checked.

	<p><b><i>On models BSM 7-60 with electrical motor brake, the brake release switch must be set to the "brake released" position before the saw wheel can be turned by hand.</i></b></p>
--	--

	<p><b><i>Adjustment of the wheel may only be carried out by trained personnel!</i></b></p>
--	--

The star knob (12) is used to adjust the inclination of the upper bandsaw wheel. This allows the position of the blade on the bandsaw wheel to be determined. Clamping lever (13) is used to clamp the star knob (12).



Figure 18: Bandsaw wheel adjustment

The blade must run on the bandsaw wheels as follows:

- **Narrow bandsaw blade** → In the middle of the wheels
- **Wide bandsaw blade** → Teeth at the edge of the wheels, but not protruding beyond them.

## 10.5 Height adjustment of the upper Saw Blade Guide

	<p><b><i>The height should be set for material processing so that the guide rollers of the saw blade guide are a maximum of 4 - 5 mm above the workpiece.</i></b></p>
--	---

The height adjustment of the upper saw blade guide (incl. saw blade guard) is done manually via the 3-arm lever<sup>4</sup> (3a) and the star knob (3b), which is used only for clamping.

### Adjust height:

- First loosen the clamp with the star knob (3b).
- Turn the 3-arm lever (3a) to the left ↶ → move upwards.
- Turn the 3-arm lever (3a) to the right ↷ → move downwards.
- After adjustment, clamp again with star knob (3b).

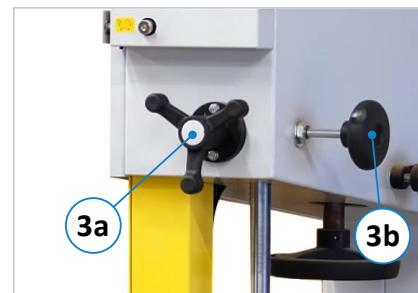

Figure 19: Lever for height adjustment

## 10.6 Swivel Table

Bandsaws of the BSM series have a swivelling table plate as standard, which can be tilted up to 45°. Clamping lever and angle scale are located on the rear side of the machine under the table.

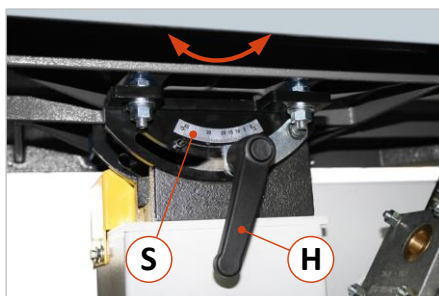

Figure 20: Adjust table inclination

### Adjust table inclination:

- Remove workpieces and workpiece-remains from the table.
- Position the fence to the right of the saw blade and fasten it.
- Release the clamping with lever (H).
- Tilt the table to the desired angle by hand.
- The angle can be read off the scale (S).
- Then clamp the table again with the lever (H).

<sup>4</sup> The model BSM 7-40 has a handwheel instead of the 3-arm lever.

## 10.7 Adjusting the GL Bandsaw Guides

This chapter only describes the adjustment of the standard bandsaw blade guides type “GL”. If your machine is equipped with the optional bandsaw blade guides type “APA”, you will find the corresponding adjustment procedure and all further information in section ⇒ 14.1.

### 10.7.1 Structure and Components

The adjustment of the two saw blade guides is necessary when starting up the machine as well as when changing the bandsaw blade.

The structure is identical for the upper and lower saw blade guide. The GL saw blade guide consists of the following components:

Pos.	Description	Pos.	Description
B	Support bolt	R	Back roller
K1	Tommy screw 1	S	Side rollers
K2	Tommy screw 2	H	Holder
L	Side bearing sleeve	X	Clamping unit
M	Lock nut		

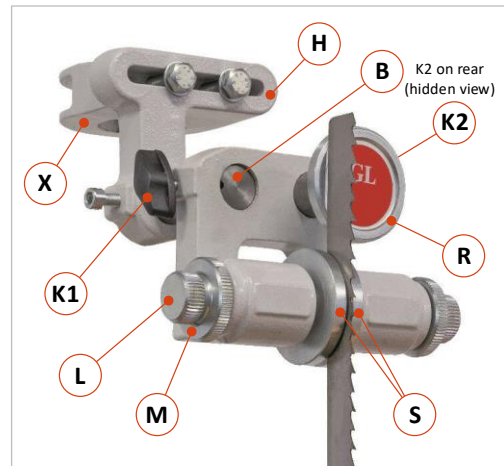

Figure 21: GL 456 - Structure and components

### 10.7.2 Adjusting the GL Saw Blade Guides

To ensure proper functioning of the bandsaw, the two saw blade guides, each with two side rollers and a back roller, must be correctly adjusted. The two side rollers serve to fix the saw blade laterally in the correct position. The purpose of the back roller is to support the bandsaw blade during cutting against the force and movement of the workpiece feed from behind.

Before adjustment, clean the guides thoroughly and remove dust, dirt and resin deposits. The procedure for adjustment is identical for the upper and lower saw blade guides:

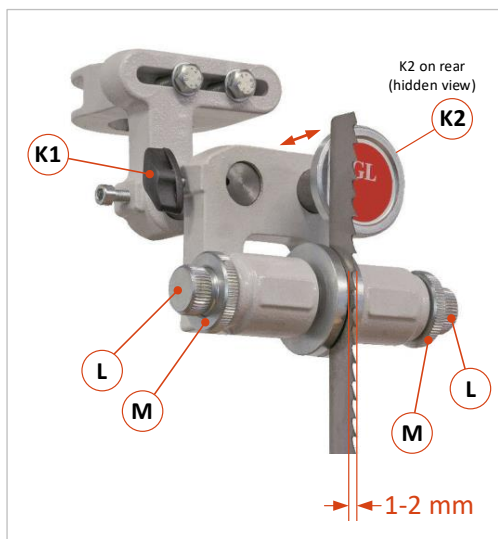

Figure 22: Adjusting the GL saw blade guides

- Loosen the back roller with the tommy screw (K2) and move it all the way back.
- Loosen the lock nuts (M) of the two side bearing sleeves (L).
- Adjust the two side rollers with the side bearing sleeves (L) outwards so that a newly placed saw blade can run freely between them.
- Place, tension and align the saw blade (see ⇒ 10.3).
- Loosen the tommy screw (K1) and adjust the complete guide on the support bolt (B) by moving it so that the front edges of the side rollers are approx. 1 - 2 mm behind the tooth base of the saw blade (see ⇒ Figure 22).
- Place the back roller so close to the back of the saw blade that it is just not touched when the machine is idle.
- The saw blade must not touch the back roller until the cutting pressure is applied during machining.

- Adjust the side rollers so that they only lightly touch the saw blade (see ⇒ Figure 23). Please take care that the saw blade is not pushed to the side!
- After adjustment, tighten the two lock nuts (M) and the tommy screws (K1) and (K2).



**The bandsaw blade guide must not be set too high during machining.  
There is a risk of injury from flying chips and a free-running saw blade!**

### 10.7.3 Basic Setting of the Back and Side Rollers (Overview)

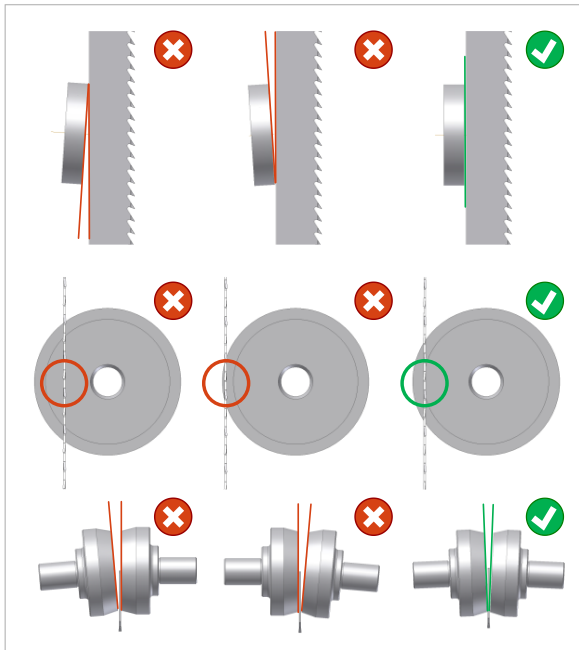

Figure 23: Basic adjustment of the back and side rollers

The two saw blade guides must be aligned with the saw blade as follows:

- The ⇒ Figure 31 shows on the far right the optimal setting of the back and side rollers. On the left and in the middle, it is shown which settings are wrong and must be avoided.
- The back roller must be parallel to the back of the saw blade (vertical), see ⇒ Figure 31 top right.
- The saw blade must run exactly in front of the inner edge of the back rollers (⇒ Figure 31, centre right).
- The side rollers may only touch the saw blade in the front area.
- The opening angles between the side rollers and the saw blade must be the same on both sides (⇒ Figure 31 bottom right).
- Both guides must be exactly vertical.
- After the basic adjustment has been made, tighten the tommy screws (**K1**) and (**K2**) again.

**Note:** For maintenance and lubrication of the saw blade guides please read the sections ⇒ 16.3 and ⇒ 16.3.1.

## 11 Using the Rip Fence

The fence is inserted into the guide rail (F) on the side of the machine table and clamped in the desired position with the clamping wheel (K). The mechanical holding device (V) can be converted in a few easy steps so that the fence is also suitable for left-handers.

The rip fence must always allow to adjust the saw blade guard as low as possible, regardless of the respective workpiece dimensions. This ensures optimum protection for the machine operator.

For this reason, the fence has a higher and a flatter surface. Depending on the workpiece dimensions, the fence can be turned by 90° in order to be able to set the ideal height for the respective workpiece to be machined.

Convert the rip fence from high to flat:

- Loosen the lever (H).
- Pull the stop bar (S) sideways out of the holding device (V).
- Then turn the rail by 90° to the right and reinsert it with the free T-slot (N) back into the holder (V).
- Now tighten the lever (H) again.
- The table stop is now set for flatter workpieces (see ⇒ Figure 25).

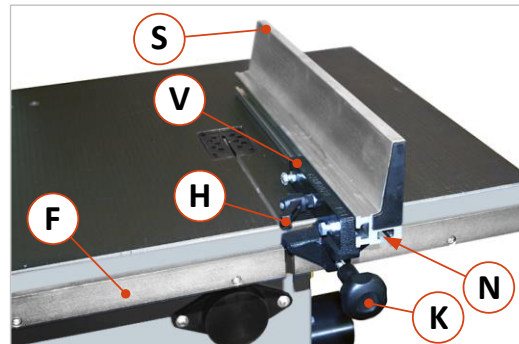

Figure 24: Fence in high position



Figure 25: Fence turned to flat position

### 11.1 Convert the Fence to the Right of the Saw Blade

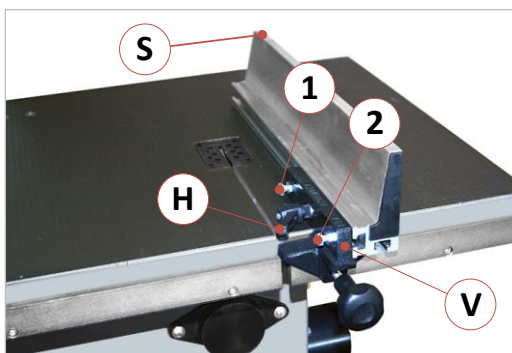

Figure 26: Converting the fence

To be able to use the fence on the right of the saw blade, the following mechanical conversion is required:

- Loosen lever (H) and pull out the fence rail (S).
- Unscrew the lever (H) and the screws (1) and (2) and pull them out of the holes of the holding device (V).
- Now insert the lever and the two screws into the holes from the other side. Then reattach the sliding blocks and tighten the screws (1) and (2) again.
- Turn the rail (S) by 180°, push it back in and clamp it with the lever (H).

## 12 Replace Table Insert

The table insert reduces the table opening of the bandsaw machine to a minimum and ensures stable guidance of the saw blade due to its narrow incision.

**Damaged table inserts must be replaced immediately!**

- Please ensure that the incision is as narrow as possible.
- Only use table inserts made of plastic or wood.
- The insert must be at table level and must not protrude above it.



Figure 27: Table insert

Matching table inserts can be ordered in the HOKUBEMA [online shop](#) (including required pin screws). The dimensions vary depending on wheel diameter). **Note:** Due to dimensional tolerances of the cast iron table tops, the table inserts must be individually fitted on site.

## 13 General Instructions for Use

### 13.1 Bandsaw Blades

Bandsaw blades must be handled carefully so that they are not damaged. Untensioned bandsaw blades must be folded into a multiple circle without kinks and secured while not in use. They are to be kept stored in a safe and dry area. Always store bandsaw blades on a surface that cannot damage the teeth of the blade. Before use, they must be checked for damaged teeth and cracks.

- To avoid cracking, tensioned bandsaw blades must be kept adequately protected.
- At least two persons are required to change a wide bandsaw blade.
- A suitable transport device is advantageous for transporting tensioned, wide bandsaw blades.
- The saw blade width, tooth shape and tooth pitch must be selected according to the thickness and nature of the workpiece.
- The saw blade must be correctly welded, ground and set. If this is not the case, the saw blade must be renewed (see section ⇒ 16.5).

 	<p><b>Caution: Danger of cutting! Put on protective gloves when changing the bandsaw blade!</b></p>
---	---

If these basic rules are not observed, the following problems may occur:

- Poor work result / unclean cut
- Poor performance
- Saw blade cracks

Blade cracks are the most common problems that occur with a bandsaw. They are mostly dependent on the saw blade. They are not caused by the machine, provided it is set according to the operating manual and has not been changed. Chapter ⇒ 15 „Troubleshooting“ lists the main causes and suggestions for preventing saw blade cracks.

### 13.2 Use of the Machine

	<p><b>Check blade tension before starting work! Never work with an untensioned saw blade!</b></p>
---	---

	<p><b>Be aware of the danger of being drawn into the rotating blade! Wearing protective gloves as well as loose clothing. Long untied hair, wristwatches and jewellery is prohibited when cutting! Always wear close-fitting clothing and a hair net if necessary.</b></p>
---	--

	<p><b>Risk of accidents and increased risk of injury! Most accidents happen when the workpieces do not have a firm hold on the machine table. Follow the instructions below!</b></p>
---	--

Place the adjustable guard on the bandsaw blade as close as possible to the workpiece. The distance between the saw blade guard and the workpiece should not exceed 5 mm when cutting.

	<p><b>Cutting hazard! Observe the danger zone of 120 mm around the saw blade!</b></p>
---	---

For **flat workpieces**, use the flat part of the table fence so that the saw blade guard can be lowered to a minimum distance from the workpiece (see chapter ⇒ 10.7).

**The workpieces must always rest firmly on the machine table.** Round workpieces must be secured against twisting, see Figure (B) on the next page. Do not cut unshapely workpieces that do not lie flat on the table or cannot be secured with one of the aids listed on next page.





**Danger of cutting if the workpiece is tilted! The saw blade can tear and cause cutting injuries.**

### Large and long workpieces

For large or long workpieces, an appropriate table extension must be used, see Figure ⇒ (A). Table extensions are available as an option (see ⇒ 14.2). For cuts without push stick, ensure a safe distance (> 10 cm) of the hands from the saw blade.

### Round and cylindrical workpieces

For round and cylindrical workpieces, slipping or rolling away of the workpieces must be prevented. These are to be secured with a handle, wedge, bolt, prism or other comparable tools, see ⇒ Figure (B).

### Short pieces - cutting splinters

Always use push sticks to prevent danger to the hands, see ⇒ Figures (C) and (D).

### Straight cuts

To prevent the workpiece from tilting or slipping away, always use the fence for straight cuts (see chapter ⇒ 10.7). It must be set to the width of the workpiece to be cut. The workpiece must rest on the table and be fed in a safe way. When feeding manually with the fence, use a push stick if it is necessary to feed close to the bandsaw blade.

### Diagonal cuts

On machines with a fixed table, there should be a secure workpiece support for diagonal cutting by means of a fixture. Use a push stick at the end of the cut.

### Tenon cutting

If a tenoning machine is not available, tenons can also be cut safely with a bandsaw.

### Crosscut sawing of upright standing workpieces

When crosscutting upright workpieces, e.g. when setting down tenons, a possible tilting of the workpiece must be prevented by a stop bracket.

### Cutting wedges

To cut small wedges on the bandsaw machine, the use of a fixture is required.

### Curved and irregular cuts

When making curved or irregular cuts on a bandsaw, it is necessary to feed the workpiece evenly. It must be held firmly on the table for effective guidance during cutting. The hands must be at a safe distance from the saw blade. A template can also be used. For repeated curved or irregular cuts, a fence fixed in front of the bandsaw blade can be used in conjunction with a template. This improves both safety and working speed.

### Cross cutting of round timber

When cross-cutting logs, the workpiece must be secured against rotation by using a fixture or holding device. Further, a bandsaw blade suitable for cross-cutting must be used.

### Cutting round plates

A suitable fixture should be used for cutting round panels. We recommend using the optional "Kreisfix" (⇒ 14.5), which is mounted together with the table extension (⇒ 14.2) and which is excellent for circular cuts.

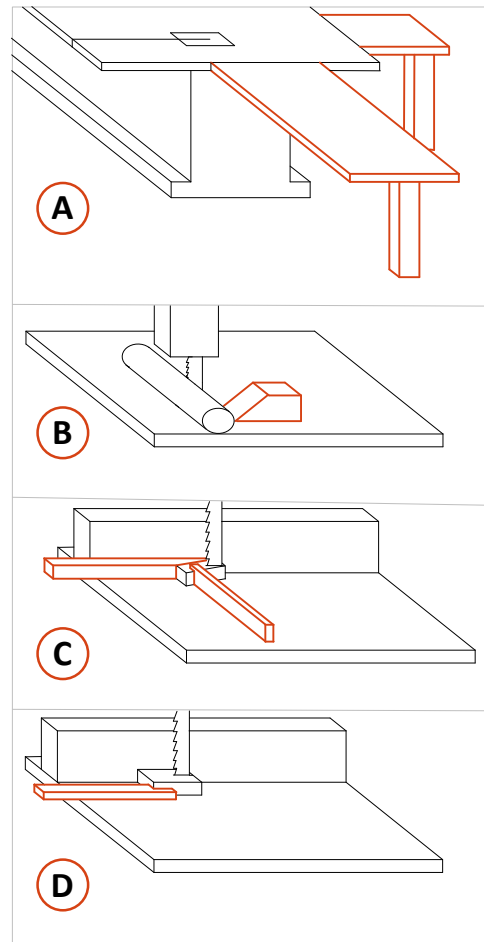

Figure 28: Table extensions and tools

### **Instruction of the operators**

It is essential that all operators are regularly and adequately instructed in the use and adjustment of safety equipment such as guards, pushers, templates and table extensions.

### **Push devices**

The push block including its handle or the push stick must be replaced if damaged.

### **Generally**

- Only use narrow saw blades for curved cutting.
- When feeding the workpiece, place your hands flat on the workpiece, do not spread your fingers.
- Do not pull the workpiece back as this may cause the saw blade to run off the rollers.
- Always feed the workpiece so that the kerf does not close.
- Always feed the lower edge to the saw blade first when cross cutting upright standing workpieces.
- Use auxiliary devices also when machining single pieces.

### **Furthermore, it should be noted that**

- the surfaces of the wheels (especially the lower one) are always free of chips,
- a functioning scraper brush is present,
- the chip catcher is attached to the lower bandsaw wheel and is not damaged,
- blurred or damaged bandsaw blades are replaced immediately,
- dirty workpieces are cleaned of dirt before cutting,
- the distance between the hands and the blade is at least 10 cm,
- and therefore pushing devices are generally used,
- pushing devices do not get into the cutting area,
- the bandsaw blade tension is released during rest periods,
- and the saw blade guard is positioned at table height at the end of work.

## **13.3 Completion of the Work**

When the machine is out of operation, e.g. at the end of a shift, position the saw blade guard all the way down to the level of the table.

Then release the tension on the bandsaw blade and place a corresponding notice on the machine. The cooling of the blade alone, which results in a reduction of the saw blade length, will cause pressure marks on the bandsaw wheel tracks. Furthermore, slight damage to the saw teeth can occur, which can lead to vibrations, etc.

## 14 Optional Components

The available optional components and accessories vary according to the bandsaw model. Please refer to the tables in chapter ⇒ 18 to see which options and accessories are available for your machine.

### 14.1 APA 2 - Saw Blade Guides

#### 14.1.1 Structure and Components

The adjustment of the two saw blade guides is necessary when starting up the machine as well as when changing the bandsaw blade.

The structure is identical for the upper and lower saw blade guide. The proven APA 2 saw blade guide consists of the following components:

Pos.	Description	Pos.	Description
<b>B</b>	Support bolt	<b>R</b>	Back roller <sup>5</sup>
<b>H</b>	Holder	<b>S</b>	Side rollers
<b>K1</b>	Tommy screw 1	<b>V</b>	Sealing plug
<b>K2</b>	Tommy screw 2	<b>X</b>	Rear clamp
<b>L</b>	Side bearing sleeve	<b>Y</b>	Front clamp

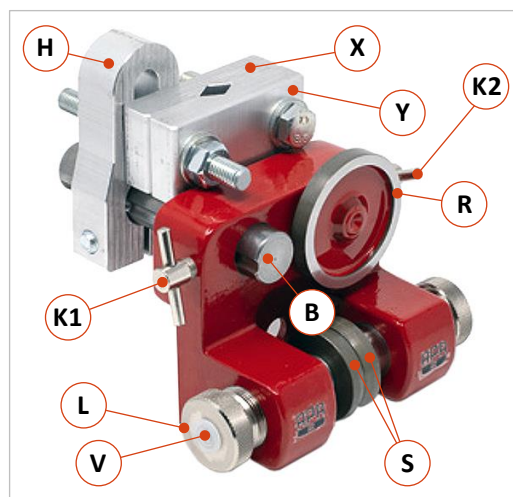

Figure 29: APA - Structure and components

#### 14.1.2 Adjusting the APA Saw Blade Guides

To ensure proper functioning of the bandsaw, the two saw blade guides, each with two side rollers and a back roller, must be correctly adjusted. The two side rollers serve to fix the saw blade laterally in the correct position. The purpose of the back roller is to support the bandsaw blade during cutting against the force and movement of the workpiece feed from behind. Before adjustment, clean the guides thoroughly and remove dust, dirt and resin deposits. The procedure for adjustment is identical for the upper and lower saw blade guides:

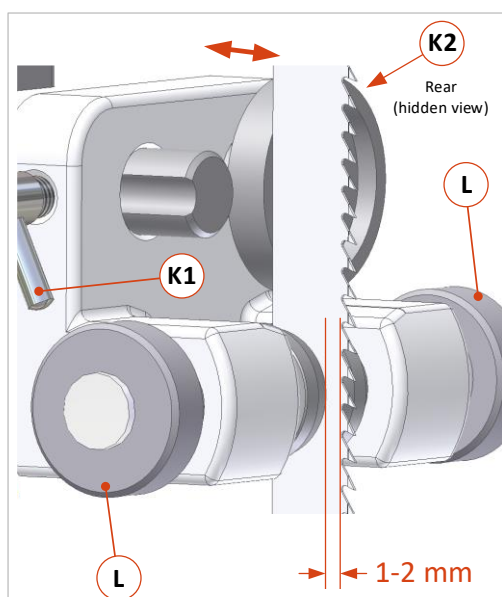

Figure 30: Adjusting the guides

- Loosen the back roller with the tommy screw (**K2**) and move it all the way back by pulling the sealing cap<sup>8</sup> on the back.
- Adjust the two side rollers with the side bearing sleeves (**L**) outwards so that a newly placed saw blade can run freely between them.
- Place the saw blade, tension and align it (see ⇒ 10.3).
- Loosen the tommy screw (**K1**) and adjust the complete guide on the support bolt (**B**) by moving it so that the front edges of the side rollers are approx. 1 - 2 mm behind the tooth base of the saw blade (see ⇒ Figure 30).
- Place the back roller against the back of the saw blade so that it is not touched when the machine is idling.
- Only the cutting pressure during machining may cause the saw blade to touch the back roller.
- Adjust side rollers so that they only lightly touch the saw blade (see ⇒ Figure 31). Please take care that the saw blade is not pushed to the side!
- After adjustment, tighten tommy screws (**K1**) and (**K2**).



**The bandsaw blade guide must not be set too high during machining.  
There is a risk of injury from flying chips and a free-running saw blade!**

<sup>5</sup> With sealing cap (not visible in picture, as attached on the back)

### 14.1.3 Basic Setting of the Back and Side Rollers (Overview)

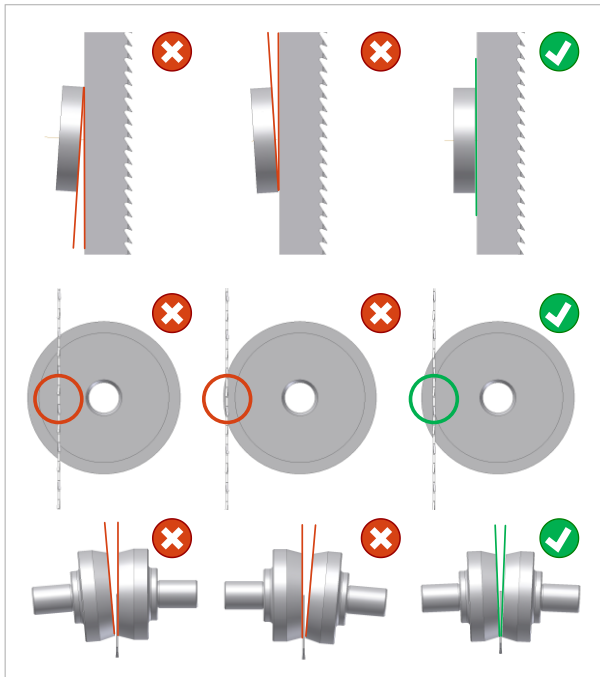

Figure 31: Basic adjustment of the back and side rollers

The two saw blade guides must be aligned with the saw blade as follows:

- The ⇒ Figure 31 shows on the far right the optimal setting of the back and side rollers. On the left and in the middle, it is shown which settings are wrong and must be avoided.
- The back roller must be parallel to the back of the saw blade (vertical), see ⇒ Figure 31 top right.
- The saw blade must run exactly in front of the inner edge of the back rollers (⇒ Figure 31, centre right).
- The side rollers may only touch the saw blade in the front area.
- The opening angles between the side rollers and the saw blade must be the same on both sides (⇒ Figure 31 bottom right).
- Both guides must be exactly vertical.
- After the basic adjustment has been made, tighten the tommy screws (K1) and (K2) again.

### 14.1.4 Conversion to Left Version

Lower Saw Blade Guide:

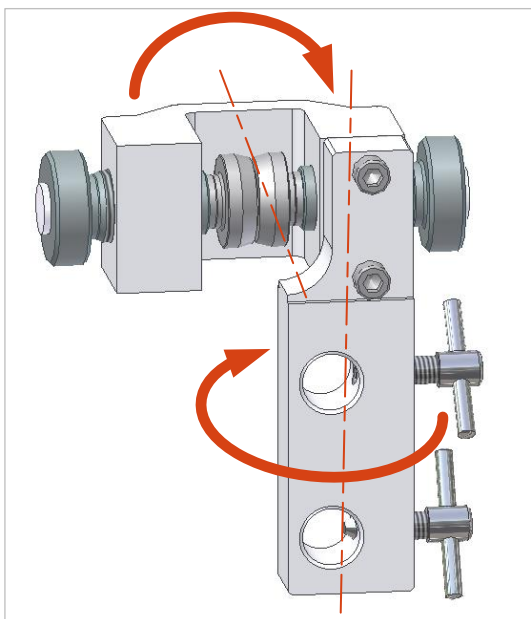

Figure 32: Convert bottom guide to left

- Loosen both tommy screws
- Remove the back roller and the support bolt from the holder.
- Remove the two fastening screws of the support.
- Rotate the holder 180° around its vertical axis.
- Rotate the guide with side rollers 180° around its horizontal axis.
- Screw the holder to the guide again.
- Reinstall the back roller and support bolt and tighten the tommy screws.

**Note:** For maintenance & lubrication of the blade guides please read the section ⇒ 16.3.

Upper Saw Blade Guide:

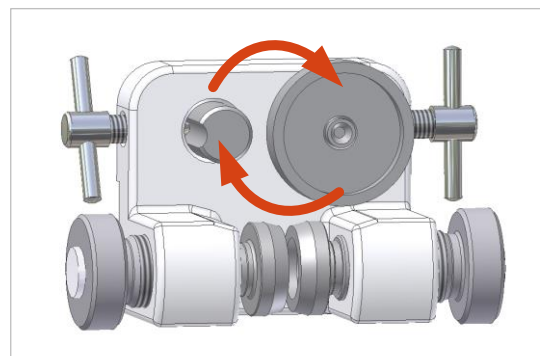

Figure 33: Convert top guide to left

- Loosen both tommy screws
- Swap the support bolt and the back roller
- Tighten the tommy screws again

## 14.2 Measurement Scale on the Table

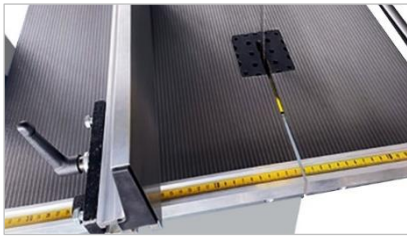

Figure 34: Measurement scale on the table

The optional measurement scale on the table makes working on the bandsaw easy and simple. The fence can be set exactly to the desired cutting dimension without the need for additional measuring equipment. The scale is firmly integrated in the machine table and its robustness ensures a long service life.

Art. No. and further accessories see chapter ⇒ 18.

## 14.3 T-Slot in the Table Top (including Mitre Fence)



Figure 35: Mitre fence „Basic“

When this option is ordered, a T-slot is integrated into the table top for attaching various work aids.

Included is the "Basic" mitre fence, which can be mounted quickly and conveniently via the existing T-slot. The adjustable range is  $\pm 60^\circ$ .

The corresponding Article No. can be found under "Options and Accessories" in chapter ⇒ 18.

## 14.4 Table Extension



Figure 36: Table extension

The optional table extension (including mounting rails) replaces an assistant and provides valuable support when machining large and long workpieces. It is easy to move, quick to remove and can be quickly mounted to the mounting rail via a clamping lever. The base is foldable and locks automatically, which ensures a small space requirement when folded.

Art. No. and further accessories see chapter ⇒ 18.

## 14.5 Kreisfix for Circular Cuts



Figure 37: Kreisfix for circular cuts

The Kreisfix is a practical aid for sawing circular workpieces. It enables precise sawing of round arcs and discs, without the need for scribing.

A prerequisite for correct mounting is that the machine is equipped with the table extension (see section ⇒ 14.2). When machining workpieces with large diameters, it is recommended to use a second table extension.

Art. No. and further accessories see chapter ⇒ 18.

## 14.6 Machine Moving Trolley



Figure 38: Machine moving trolley

With the optional mobile trolley, you can make your bandsaw mobile and are no longer tied to a stationary installation site. This allows you to move your machine quickly and conveniently to any desired location in your workshop or joinery. The trolley for easy transport consists of two swivel castors with brakes and two fixed castors.

Art. No. and further accessories see chapter ⇒ 18.

## 15 Troubleshooting

Proceed systematically when searching for the cause of a malfunction. If you are unable to find the fault or to remedy the malfunction, contact our customer service department (phone number: +49 (0) 7571 / 755-0).

Before you call us, please follow these steps:

- Make a note of the type, machine number and year of production (see nameplate).
- Keep this operating manual (and any circuit diagrams) to hand.
- Describe the fault to us in detail so that a competent remedy can be found.

Fault	Possible Cause	Remedy
Bandsaw does not start	No voltage	→ Check connections
	Control fuse defective	→ Replace fuse
	ON/OFF switch defective	→ Replace switch
	Motor defective	→ Replace motor
	Broken V-belt	→ Replace V-belt
	Brake release switch <sup>6</sup> is activated	→ Switch off
	Doors not closed	→ Close the doors
	Door safety switch not locked	→ Lock safety switches (⇒ 10.2)
Motor becomes very hot	Overload or defective motor	→ Contact customer service
Brake motor no longer brakes within 10 sec.	a) Brake needs to be readjusted <sup>6</sup> b) Brake pads are worn <sup>6</sup> c) The brake is defective	→ Adjust <sup>6</sup> the brake according to ⇒ 16.8. If unsuccessful, contact customer service.
Machine whistles when starting	V-belt for drive too loose	→ Retighten V-belt (⇒ 16.6)
Saw blade is braked heavily during machining	V-belt for drive slipping	→ Retighten V-belt (⇒ 16.6)
Bandsaw blade runs untrue	Bandsaw blade tension too low	→ Tension saw blade (⇒ 10.3)
	Upper guide set too high away from workpiece	→ Position guide max. 4 - 5 mm above the workpiece
	Upper and lower guide are not adjusted correctly	→ Adjust side rollers according to section ⇒ 14.1.2
	Welding point not straight	→ Replace saw blade
Machine vibrates strongly	Machine stand uneven	→ Realign (see ⇒ 7.3)
	Drive wheel surfaces Are dirty or damaged	→ Clean / replace
Cutting path is crooked	Saw blade is blunt	→ Resharpener or replace
	Saw blade guide incorrectly adjusted	→ Readjust saw blade guide according to section ⇒ 14.1.2

Continuation on the next ⇒ page

<sup>6</sup> Only relevant for model BSM 7-60

Troubleshooting - Continuation

Fault	Possible Cause	Remedy
Saw blade breaks	Bad weld	→ Replace saw blade
	Too sharp edges at the tooth base	→ Use a saw blade that is suitable for the intended use
	Saw blade guide badly adjusted, the back roller presses against the saw blade	→ Readjust saw blade guide according to section ⇒ 14.1.2
	Manual feed rate too high	→ Select feed rate according to the material
	Saw blade blunt or badly set	→ Replace saw blade
	Saw blade torn or teeth burnt due to incorrect grinding	→ Regrind or replace
	Resin residues or similar on the saw blade	→ Clean the saw blade and the wheel bandages
	Saw blade badly ground or teeth not adapted to the cut	→ Replace saw blade

15.1.1 Saw Blade Guides - Troubleshooting

Fault	Possible Cause	Remedy
The side rollers or back rollers do not rotate	Insufficient or incorrect lubrication	→ Clean bearings and oil according to section ⇒ 16.3.
	Incorrect basic adjustment of the guide	→ Check basic adjustment (⇒ Figure 31) and readjust if necessary (see section ⇒ 14.1.2).
	Poor cleaning	
The back roller is cut by the back of the saw blade	Back roller does not rotate	→ Clean bearings and oil according to section ⇒ 16.3.
	Saw blade runs too far inside on the back roller	→ Check basic adjustment (⇒ Figure 31) and readjust if necessary (see section ⇒ 14.1.2).
The running surface of the back roller wears more on the outside than on the inside	Saw blade runs too far too far out on the backrest roller	→ Check basic adjustment (⇒ Figure 31) and readjust if necessary (see section ⇒ 14.1.2).
	The back roller is not exactly vertical to the back of the saw blade	
The saw blade is pushed forward by the side rollers	The side rollers are too tight to the saw blade	→ Adjust side rollers correctly according to section ⇒ 14.1.2 and clean dirty parts.
	The running surfaces of the side rollers or saw blade are dirty	

## 16 Maintenance and Inspection



***Before any maintenance and inspection work is carried out, chapter ⇨ 5 "Safety" must be read carefully and observed!***

Operational malfunctions caused by insufficient or improper maintenance can result in very high repair costs and long machine downtimes. Regular maintenance is therefore essential.

- Clean the machine daily.
- Check all sliding or rolling parts weekly for smooth running and lubricate with a thin-bodied oil if necessary.
- Inspect electrical equipment/components weekly for externally visible damage and have them repaired by a qualified electrician if necessary.
- Immediately remove and replace damaged guards. Never work with damaged equipment!
- Before starting work, check the extraction system for full function every day.
- The extraction system must be checked for obvious defects before initial commissioning, daily and monthly to ensure its effectiveness.
- The air velocity to the extraction system must be checked before the initial commissioning and after significant modifications.
- The function of the gas springs should be checked occasionally. If it takes a lot of force to open the protective cover, the gas springs must be replaced.
- Do not use the machine until these conditions are met.

Due to the different operating conditions, it is not possible to determine in advance how often a wear check, inspection or maintenance is required. Inspection intervals are to be determined appropriately according to the respective operating conditions.

### 16.1 Replace Ball Bearings

If the ball bearings become noisy or have play, they must be replaced. To do this, the corresponding bandsaw wheel must be removed to make the old ball bearings accessible and replace them with new ones.



***Disconnect the machine from the mains during maintenance and repair work and secure it against unintentional restarting!***

To remove or install the ball bearings, use a suitable device (e.g. puller / mounting tube) to avoid damaging the bearings. Please refer to the following table for the ball bearing type suitable for your machine:

<b><i>Model</i></b>	<b><i>BSM 7-40</i></b>	<b><i>BSM 7-50</i></b>	<b><i>BSM 7-60</i></b>
<b><i>Ball Bearing Type</i></b>	6204 2RS	6205 2RS	6305 2RS



## 16.2 Lubrication of the Machine

The machine itself does not require lubrication. All ball bearings are maintenance-free.

## 16.3 Maintenance and Lubrication of the Saw Blade Guides

The bandsaw blade guides should be lubricated every six months with a few drops of manufacturer's special oil (see below). Depending on the frequency of use and the stress, a shorter lubrication interval should be selected.

### Maintenance / Cleaning:

Clean the saw blade guides regularly (min. 1 x per week) from sawdust, splinters, resin or other dirt.

### Lubrication:

The bright steel parts of the guides are to be kept smooth-running and rust-free at regular intervals by light oiling.

For lubrication we recommend our special oil 1059 (⇒ Figure 39), which is available in the manufacturer's [online shop](#) (content: 5 bottles, 20 ml each).



Figure 39: Special oil 1059



**Important: Never use grease to lubricate the bearings!**

### 16.3.1 Oil "GL" Saw Blade Guides

Before oiling the bandsaw blade guides, they must first be cleaned resp. thoroughly freed from sawdust, splinters, resin or other residues and dirt. The procedure is identical for the upper and lower saw blade guides. Always oil the upper and lower guides at the same time.

#### Oil the side rollers and back roller:

- Apply a few drops of special oil to the running surfaces of the roller axles. roller axles (see marked areas in ⇒ Figure 40).



Figure 40: Oil GL saw blade guides

### 16.3.2 Oil "APA" Saw Blade Guides

Before oiling the bandsaw blade guides, they must first be cleaned resp. thoroughly freed from sawdust, splinters, resin or other residues and dirt. The procedure is identical for the upper and lower saw blade guides. Always oil the upper and lower guides at the same time.

#### Oil Side Rollers:

- Remove the sealing plugs from the rollers and put a few drops of oil in the bearings (see ⇒ Figure 41).
- Refit the sealing plugs.
- The O-rings in the side bearing sleeves should occasionally be lubricated with a little acid-free grease (preferably Vaseline).

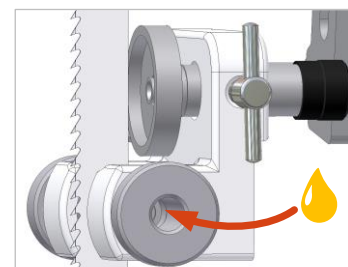

Figure 41: Oil APA side rollers

#### Oil Back Roller:

- Unscrew the sealing cap from the back roller bearing (⇒ Figure 42).
- Press a little oil into the lubrication hole on the front of the bearing bolt.
- Screw the sealing cap back on.

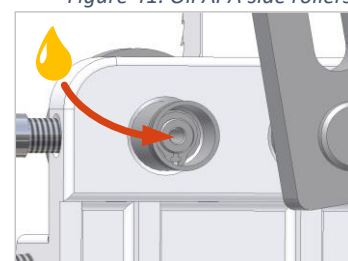

Figure 42: Oil APA back roller

## 16.4 Bandsaw Roll Coating

The bandsaw roller contact area is made of a specially vulcanised material that is highly resistant to wear and tear. Usually, the surface lasts for many years. If the surface should nevertheless become worn, special cork bandages can be applied, which are available in the manufacturer's [online shop](#).

If required, you can also contact our wheel repair service  
(phone: 07571 / 755-0 | E-Mail: [info@hokubema-panhans.de](mailto:info@hokubema-panhans.de)).

- The running surfaces must always be kept clean and free of incrustations.
- In addition, it must be ensured that the balling is correct and clean.

## 16.5 Replacing the Bandsaw Blade

As soon as the bandsaw blade cracks, cuts badly, runs untrue or becomes too noisy, it should be replaced. The instructions in section ⇨ 10.3 must be followed.

**Note:** Please only use the manufacturer's original bandsaw blades suitable for the bandsaw (see chapter ⇨ 18).

## 16.6 Retighten the V-belt



**Disconnect the machine from the mains during maintenance and repair work and secure it against unintentional restarting!**

- Disconnect the machine from the mains and secure it.
- Unlock the door safety switch for the lower door according to section ⇒ 10.2 and open the door.
- Slightly loosen the 4 screws (**M**) on the motor.
- Tighten the tensioning nut (**S**) on the threaded rod (**G**) with an open-ended spanner SW17 until the correct V-belt tension is achieved.

### Checking the V-belt Tension:

It must be possible to push the belt through by hand between the two axles by approx. 10 mm.

- Tighten the screws (**M**) on the motor again.
- Close the lower bandsaw door again and lock it with the safety switch (see ⇒ 10.2).

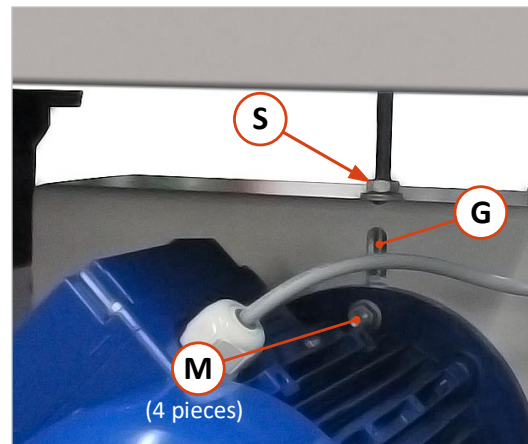

Figure 43: Retighten the V-belt

## 16.7 Replacing the V-belt

Model	BSM 7-40	BSM 7-50	BSM 7-60
V-belt Type	SPZ 912 LP / SPZ 912 LW	13 1100 Li (A43)	13 1100 Li (A43)



**Disconnect the machine from the mains during maintenance and repair work and secure it against unintentional restarting!**



**Only V-belts with the same cross-section and length may be used.**



**Cutting hazard! Wear protective gloves when handling the bandsaw blade!**

- Disconnect the machine from the mains and secure it.
- Unlock the two safety switches according to section ⇒ 10.2 open both bandsaw doors.
- Release the tension on the saw blade (**B**) and remove it (see procedure in section ⇒ 10.3).
- Slightly loosen the 4 screws (**M**) on the motor.
- Loosen the tensioning nut (**S**) on the threaded rod (**G**) until the V-belt is loose.
- Remove the hexagon head screw (**N**) and washer (**U**) from the roller hub.
- Gently pull out the lower bandsaw wheel (**R1**) (please be careful, the wheel is very heavy!).
- Remove belt and insert new belt in the pulley of the bandsaw wheel.
- Tighten the belt according to section ⇒ 16.6.
- Refit the lower wheel (**R1**) and reinsert the saw blade.
- Close doors and lock with safety switch (see ⇒ 10.2).

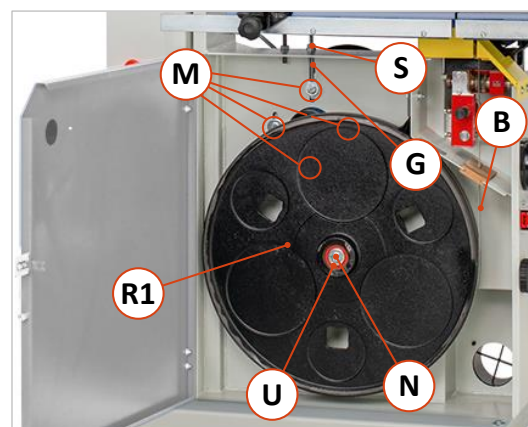

Figure 44: Replacing the V-belt

## 16.8 Readjusting the BSM 7 -60 Main Motor Brake



**Disconnect the machine from the mains during maintenance and repair work and secure it against unintentional restarting!**

If the machine does not come to a standstill within 10 seconds when braking, the motor brake must be readjusted.

### Procedure:

- Disconnect the machine from the power supply and secure it or turn off the main switch and lock it.
- Insert an angled SW5 Allen key through the fan cover and insert it into the hexagon socket of the front-side set screw (see ⇒ Figure 45).
- Turn the Allen key approx. 1/8 turns clockwise as shown in ⇒ Figure 45).

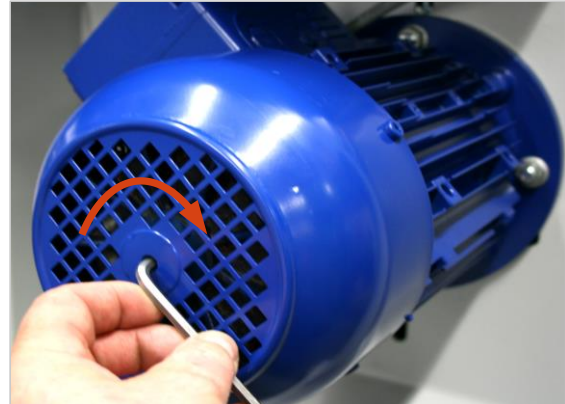

Figure 45: Readjusting the BSM 7-60 motor brake

### 16.8.1 Check the Adjustment

- Before checking the adjustment, make sure that the belt is well tensioned (see ⇒ 16.6).
- Then reconnect the machine to the power supply or unlock the main switch and switch on.
- Turn the brake release switch to the “**brake released**” position.
  - Now it must be possible to move the saw blade by hand. By turning it, you can now check whether the brake is dragging, which means that it has been adjusted too excessively.
  - If the brake is dragging, the readjustment made must be minimally reversed again.



**Cutting hazard! Wear protective gloves when handling the bandsaw blade!**

- Now turn the brake release switch back to “**inactive**” position.
- Start the bandsaw blade and wait until the machine has reached full speed.
- Then switch off the bandsaw and check the braking time to standstill.
- If the braking time is still over 10 seconds, repeat the setting procedure (see section ⇒ 16.8) and check the adjustment again.
- If the adjustment was not successful, please contact the customer service of the manufacturer.



**If rattling noises occur in the area of the fan blade when turning the motor, please contact the customer service. Possibly the brake lining is worn out.**

## 16.9 Motor Brake on Models BSM 7-40 and BSM 7-50

The motor brake cannot be readjusted on the motors of these models, as they are equipped with an electrical motor brake.

If you have problems with the motor brake, please contact our customer service (phone: +49 (0) 7571 / 755-0).

## 17 Disassembly and Scrapping

When dismantling and scrapping the machine, the current EU regulations or the respective regulations and laws of the country of operation, which are prescribed for proper dismantling and disposal, must be observed. The aim is to dismantle the machine and its various materials and components properly, to recycle all possible parts and to dispose of non-recyclable components in the most environmentally friendly way.

	<p><b>Please pay particular attention to</b></p> <ul style="list-style-type: none"> <li>• <i>the dismantling of the machine in the working area</i></li> <li>• <i>proper dismantling of the machine and accessories</i></li> <li>• <i>a safe and proper removal of the machine</i></li> <li>• <i>proper separation of all components and materials.</i></li> </ul>
---	--

When dismantling and disposing the machine, the laws and regulations in force at the place of use concerning health and environmental protection must be observed.

	<p><b>Remove all residues of oil, grease and other lubricants and have them disposed of properly by a qualified disposal company.</b></p>
---	---

When separating, disposing of or recycling the machine materials, comply with the environmental protection laws in force at the place of use regarding the disposal of industrial solid waste toxic and hazardous waste.

	<ul style="list-style-type: none"> <li>• <b><i>Hoses and plastic parts as well as other components that are not made of metal must be dismantled and recycled or disposed of separately.</i></b></li> <li>• <b><i>Electrical components such as cables, switches, connectors, transformers, etc. must be removed and (if possible) recycled or otherwise disposed of in a qualified manner.</i></b></li> <li>• <b><i>Pneumatic and hydraulic parts such as valves, solenoid valves, pressure regulators, etc. must be removed and (if possible) recycled or otherwise disposed of in a qualified manner.</i></b></li> <li>• <b><i>Dismantle the base frame and all metal parts of the machine and sort them according to material type. Metals can be melted down and recycled.</i></b></li> </ul>
--	--

In the event of improper disposal of lubricants, the following residual risks to the environment and health exist:

	<p><b>Pollution of the environment by seepage into groundwater or sewage system.</b></p>
---	--

	<p><b>Poisoning of the personnel contracted for the disposal.</b></p>
---	---

**Note:** The disposal of lubricants considered toxic and hazardous must be carried out in accordance with the regulations and laws in force at the respective place of use. Only qualified disposal companies that have the appropriate permits for the disposal of used oil and lubricants are to be commissioned with the disposal.

## 18 Options and Accessories

In the following tables you will find available options and accessories for each bandsaw model of the BSM series. General spare parts such as cork bandages, table inserts, special oil for bandsaw blade guides etc. can be found in the online shop <https://www.hokubema.com>.

	<p><b>Only use original bandsaw blades, accessories and spare parts specified by the manufacturer. The use of other accessories or spare parts can cause injury to persons and damage to the machine. The manufacturer accepts no liability for any damage resulting from the use of non-prescribed accessories and spare parts or additional components from third parties!</b></p>
---	--

### 18.1 BSM 7-40 - Bandsaw Blades

Blade Length	Width	Thickness	Span Width	Quality	Art. No.
3300 mm	20	0.45 mm	6	1002	3783.20G
3300 mm	15	0.45 mm	6	1002	3783.15G
3300 mm	10	0.40 mm	6	1002	3783.10G

### 18.2 BSM 7-40 - Options and Accessories

Article	Description	Art. No.
<b>PRECISION BANDSAW BLADE GUIDE</b>	Top and bottom, type APA 2, size 1 (instead of type GL).	5211
<b>T-SLOT IN THE MACHINE TABLE</b>	Including mitre fence "Basic".	5190
<b>FIXATION RAILS</b>	2 pieces (Length = 430 mm), for quick and safe attachment of safety and working devices.	5277
<b>TABLE EXTENSION</b>	For suspension in fastening rail, replaces an assistant when machining long workpieces.	5279
<b>KREISFIX</b>	The practical aid for circular cutting, enables precise cutting of curves and discs without scribing, and is very easy to handle (only in conjunction with table extension part No. 5279).	5280
<b>MEASUREMENT SCALE ON TABLE</b>	For exact dimensioning of the fence.	5123
<b>MOVING TROLLEY</b>	With 2 swivel castors with brakes and 2 fixed castors.	5270

### 18.3 BSM 7-50 - Bandsaw Blades

Blade Length	Width	Thickness	Span Width	Quality	Art. No.
4140 mm	25	0.45 mm	7	1002	3783.25K
4140 mm	20	0.45 mm	6	1002	3783.20K
4140 mm	15	0.45 mm	6	1002	3783.15K
4140 mm	10	0.40 mm	6	1002	3783.10K

### 18.4 BSM 7-50 - Options and Accessories

Article	Description	Art. No.
<b>PRECISION BANDSAW BLADE GUIDE</b>	Top and bottom, type APA 2, size 1 (instead of type GL).	5211
<b>T-SLOT IN THE MACHINE TABLE</b>	Including mitre fence "Basic".	5190
<b>FIXATION RAILS</b>	2 pieces (Length = 430 mm), for quick and safe attachment of safety and working devices.	5277
<b>TABLE EXTENSION</b>	For suspension in fastening rail, replaces an assistant when machining long workpieces.	5279
<b>KREISFIX</b>	The practical aid for circular cutting, enables precise cutting of curves and discs without scribing, and is very easy to handle (only in conjunction with table extension part No. 5279).	5280
<b>MEASUREMENT SCALE ON TABLE</b>	For exact dimensioning of the fence.	5123
<b>MOVING TROLLEY</b>	With 2 swivel castors with brakes and 2 fixed castors.	5271

## 18.5 BSM 7-60 - Bandsaw Blades

Blade Length	Width	Thickness	Span Width	Quality	Art. No.
4735 mm	20	0.60 mm	9	1000	3780.25D
4735 mm	15	0.70 mm	8	1000	3780.20D
4735 mm	10	0.70 mm	6	1000	3780.10D

## 18.6 BSM 7-60 - Options and Accessories

Article	Description	Art. No.
<b>PRECISION BANDSAW BLADE GUIDE</b>	Top and bottom, type APA 2, size 2 (instead of type GL).	5217
<b>T-SLOT IN THE MACHINE TABLE</b>	Including mitre fence "Basic".	5190
<b>FIXATION RAILS</b>	2 pieces (Length = 430 mm), for quick and safe attachment of safety and working devices.	5277
<b>TABLE EXTENSION</b>	For suspension in fastening rail, replaces an assistant when machining long workpieces.	5279
<b>KREISFIX</b>	The practical aid for circular cutting, enables precise cutting of curves and discs without scribing, and is very easy to handle (only in conjunction with table extension part No. 5279).	5280
<b>MEASUREMENT SCALE ON TABLE</b>	For exact dimensioning of the fence.	5123
<b>MOVING TROLLEY</b>	With 2 swivel castors with brakes and 2 fixed castors.	5272



# CE EU - Declaration of Conformity

in accordance with the EU Machinery Directive 2006/42/EC Annex II A

**The manufacturer,**

HOKUBEMA Maschinenbau GmbH  
Graf-Stauffenberg-Kaserne  
Binger Str. 28 | Halle 120  
D- 72488 Sigmaringen (Germany)

Phone: +49 (0) 7571 / 755 - 0  
Fax: +49 (0) 7571 / 755 - 222

hereby declares that the manufactured machine

***Bandsaw Machine TYPE BSM 7-40 | BSM 7-50 | BSM 7-60***

Machine-No.: .....

Year of manufacture: .....

in the version provided complies with the following directives:

- Machinery Directive 2006/42/EC
- EMC Directive 2014/30/EU

Harmonised standards applied, in particular:

- EN 1807-1

The notified body (0392)

**DGUV Test**  
**Prüf- und Zertifizierungsstelle Holz**  
**Fachbereich Holz und Metall**  
**Vollmoellerstraße 11**  
**70563 Stuttgart (Germany)**

has carried out an EC type-examination for the above machine.

Mr. Andreas Ganter, Graf-Stauffenberg-Kaserne, Binger Str. 28 | Halle 120,  
72488 Sigmaringen (Germany), is authorised to compile the technical documentation.

Type Examination Certificate No.: **HO 141058 (EG)** and **HO141059 (GS)**

Sigmaringen, 21.04.2022

.....



.....

Reinhold Beck  
Managing Director