

TRANSLATION OF THE ORIGINAL VERSION



CE

Operating Manual

Sliding Table Saw WOODPECKER FKS 6-315/2300



Machine Type: FKS 6-315/2300

WOODPECKER

HOKUBEMA Maschinenbau GmbH

Graf-Stauffenberg-Kaserne, Binger Str. 28 | Halle 120

DE 72488 Sigmaringen | Tel. +49 07571 755-0

E-Mail: info@ichbinwoodpecker.de | Web: <https://www.ichbinwoodpecker.de>

Space for notes:

HOKUBEMA Maschinenbau GmbH

Graf-Stauffenberg-Kaserne
 Binger Straße 28 | Halle 120
 DE 72488 Sigmaringen
 Tel.: +49 (0)7571-755-0
 Fax: +49 (0)7571-755-222

<h2>Handover Certificate</h2>		
Machine type:		
Machine no.:		
Construction year:		
Customer address (location of the machine):		
Name:		
Street:		
Postcode/City:		
Phone:	Fax:	
E-mail:		
<p>Warranty: On the basis of our Terms and Conditions of Sale, Delivery and Payment of the respective current status, we assume a warranty of 12 months, calculated from the day of delivery, for material defects and defects of title in connection with the delivery for the above-mentioned machine.</p>		
<p>Warranty claims: Warranty claims on the part of HOKUBEMA Maschinenbau GmbH only exist if we have received the signed handover certificate and the machine has been properly commissioned. We therefore ask for immediate return.</p> <p>Important: Please read and follow the instructions in chapter ⇒ 1 "<u>Liability and Warranty</u>".</p>		
<p>Confirmation of the buyer:</p> <ul style="list-style-type: none"> ✓ The machine described above was purchased by me/us. ✓ Together with this handover certificate, I have received the operating manual valid for the machine (edition: _____). ✓ The operating instructions have been read and understood by me, as well as by all persons responsible for operating the specified machine. I will ensure that persons working on the machine at a later date are also instructed accordingly. 		
_____ Name and position	_____ Date	_____ Signature of the customer
<p>Address of the dealer (company stamp):</p>	<p>The machine, including the operating manual, was handed over to the buyer and installed according to the specifications in the operating manual.</p>	
	_____ Date	_____ Signature - Customer Service

Space for notes:

HOKUBEMA Maschinenbau GmbH

Graf-Stauffenberg-Kaserne
 Binger Straße 28 | Halle 120
 DE 72488 Sigmaringen
 Tel.: +49 (0)7571-755-0
 Fax: +49 (0)7571-755-222

<h2>Handover Certificate</h2>		
Machine type:		
Machine no.:		
Construction year:		
Customer address (location of the machine):		
Name:		
Street:		
Postcode/City:		
Phone:	Fax:	
E-mail:		
Warranty:		
<p>On the basis of our Terms and Conditions of Sale, Delivery and Payment of the respective current status, we assume a warranty of 12 months, calculated from the day of delivery, for material defects and defects of title in connection with the delivery for the above-mentioned machine.</p>		
Warranty claims:		
<p>Warranty claims on the part of HOKUBEMA Maschinenbau GmbH only exist if we have received the signed handover certificate and the machine has been properly commissioned. We therefore ask for immediate return.</p>		
<p>Important: Please read and follow the instructions in chapter ⇒ 1 "<u>Liability and Warranty</u>".</p>		
Confirmation of the buyer:		
<ul style="list-style-type: none"> ✓ The machine described above was purchased by me/us. ✓ Together with this handover certificate, I have received the operating manual valid for the machine (edition: _____). ✓ The operating instructions have been read and understood by me, as well as by all persons responsible for operating the specified machine. I will ensure that persons working on the machine at a later date are also instructed accordingly. 		
_____ Name and position	_____ Date	_____ Signature of the customer
Address of the dealer (company stamp):	<p>The machine, including the operating manual, was handed over to the buyer and installed according to the specifications in the operating manual.</p>	
	_____ Date	_____ Signature - Customer Service

Table of Contents

1	Liability and Warranty	11
2	Introduction.....	12
2.1	Legal Notice	12
2.2	Figures.....	12
3	Symbols	12
3.1	General Symbols	12
3.2	Symbols in Safety Instructions	13
4	General	14
4.1	Intended Use.....	15
4.2	Target Group and Previous Experience.....	15
4.3	Requirements for the Operators.....	15
4.4	Training of Personnel	15
4.5	Accident Prevention.....	16
4.6	General Safety Regulations	16
4.7	Structure and Function	17
4.8	Standard Equipment	17
4.9	Options and Accessories	17
5	Safety.....	18
5.1	Basic Safety Instructions	18
5.2	Application Area and Intended Use	18
5.3	Modifications and Conversions to the Machine	18
5.4	Residual Risks.....	19
5.5	Observe the Environmental Protection Regulations.....	20
5.6	Organisational Measures	21
5.7	Personnel Selection and Qualification - Basic Duties	21
5.8	Safety Instructions for Specific Phases of Operation	22
5.8.1	Normal Operation	22
5.8.2	Special work within the Scope of Maintenance Work as well as Troubleshooting in the Workflow.....	22
5.9	Safe Working Practices	23
5.10	Construction-related Safety Equipment	24
5.11	Electrical Safety Equipment	24
5.12	Hazardous Areas on the Sliding Table Saw	25
5.12.1	Danger Zone Saw Blade.....	25
5.12.2	Danger Zones around the Machine	25
5.13	Avoidance of Kickback Hazards.....	26
5.13.1	Use fence and saw blade guard	26
5.13.2	Never work without the riving knife.....	26
5.13.3	Use anti-kickback devices	26
5.13.4	Rip fence when cutting short workpieces to width	26
5.13.5	Parallelism of the rip fence.....	27
5.13.6	Cutting off small pieces on the rip fence	27

5.13.7	Insert cutting	27
6	Machine Data	28
6.1	Technical Specifications	28
6.2	Emission Levels	29
6.2.1	Noise Information.....	29
6.2.2	Noise Emission Values	29
6.3	Workplace Requirements	29
6.4	Maximum Dimensions	30
7	Installation and Connection	31
7.1	Check Delivery Conditions	31
7.2	Transport	31
7.2.1	Unloading with a Forklift Truck.....	31
7.2.2	Setting down with a Forklift Truck.....	31
7.2.3	Lifting and Parking with an Overhead Crane	32
7.3	Machine Installation	32
7.4	Temporary Storage	33
7.5	Lashing in a Transport Vehicle	33
7.6	Connecting the Extraction Unit.....	34
7.6.1	Automatic switching of the Extraction System (Option).....	34
7.7	Electrical Connection	35
7.7.1	Supply Cable and External Fuse Protection	35
7.7.2	Check Direction of Rotation.....	35
8	Components and Controls.....	36
9	Saw Blade Positioning	37
9.1	Height Setting of the Saw Blade.....	37
9.2	Tilt Setting of the Saw Blade	37
10	Mounting and Usage	38
10.1	Mounting and Adjusting the Saw Blade	38
10.1.1	Preparation: Making the circular saw shaft accessible	38
10.1.2	Replacing / Mounting a Saw Blade	39
10.1.3	Adjusting the Riving Knife.....	40
10.1.4	Fitting and Adjusting the Saw Blade Guard	40
10.1.5	Optional Overhead Saw Blade Guard	40
10.1.6	Scoring Unit (Option).....	41
10.1.7	Replacing / Mounting a Scoring Saw Blade.....	41
10.1.8	Setting the Scoring Saw	42
10.2	Mounting and Adjusting the Cross-cut Carriage	43
10.3	Attaching the Cross-cut Carriage	43
10.4	Moving the Cross-cut Carriage.....	43
10.5	Removing the Cross-cut Carriage.....	43
10.6	Mounting and Adjusting the Cross-cut Fence.....	44
10.6.1	Checking the tape measure for the cross-cut fence	45
10.7	Sliding Table	45

10.8	Mounting the Rip Fence	46
10.9	Operating the Rip Fence	47
10.9.1	Setting the Rip Fence	47
10.9.2	Change stop profile from high to flat	47
10.9.3	Folding the Rip Fence away	47
10.10	Mounting the Table Extension	48
10.11	Mounting the Extension Table	48
10.12	Eccentric Clamping Device	49
10.13	Clamping Shoe	49
10.14	Push Stick	49
11	Commissioning	50
11.1	Operating Switches	50
11.1	Switching ON and OFF	50
11.2	Switch ON the Sawing Unit	50
11.3	Switch OFF the Sawing Unit	50
11.4	Emergency Stop Function	50
12	Working with the Sliding Table Saw	51
12.1	General Instructions	51
12.2	Permissible Working Techniques	51
12.3	Improper Working Techniques	51
12.4	Permitted Operations	52
12.4.1	Longitudinal cutting of narrow Workpieces < 120 mm	52
12.4.2	Cutting Battens	52
12.4.3	Edge Cutting (Trimming)	52
12.4.4	Cross-cutting of wide Workpieces	52
12.4.5	Cross-cutting of narrow or short Workpieces	53
12.4.6	Cutting Workpieces to Length	53
12.4.7	Dividing large Panels	53
12.5	Conditionally permitted Operations	54
12.5.1	Concealed Cutting (Rebating)	54
12.5.2	Insert Cutting	54
13	Troubleshooting	55
13.1	Faults with optional Scoring Saw	56
14	Maintenance and Inspection	57
14.1	Cleaning	57
14.2	Lubrication	58
14.3	Checking the Electronic Motor Brake	58
14.4	Checking the Safety Devices	58
14.4.1	Checking the Emergency Stop Buttons	58
14.4.2	Checking the internal Safety Switch	58
14.4.3	Checking the Safety Labels	58
14.4.4	Checking the Saw Blade Guard	59
14.4.5	Checking the Riving Knife	59

14.4.6	Checking the Push Stick	59
14.5	Checking the Rip Fence	59
14.6	Checking the Cross-Cut Fence Tape Measure	59
14.7	Changing and Tensioning the Drive Belt	60
14.7.1	Checking the Drive Belt Tension	60
14.8	Maintaining the Drive Belt	60
14.9	Taking the Machine out of Operation / Storage	61
14.10	Defects and their Remedy	61
14.11	Average Situations / Emergencies	61
15	Electrical Circuit Diagram	62
16	Options and Accessories	63
16.1	Circular Saw Blades	63
16.2	Optional Accessories	63
17	Disassembly and Scrapping	64
	EU - Declaration of Conformity	65

List of Figures

Figure 1:	Circular saw blade with guard	12
Figure 2:	Danger zone saw blade	25
Figure 3:	Danger zones around the machine	25
Figure 4:	Cutting short workpieces to width	26
Figure 5:	Fixing the deflector wedge on the table	27
Figure 6:	Name plate	28
Figure 7:	Working areas	29
Figure 8:	Maximum dimensions - top view	30
Figure 9:	Unloading with a forklift truck	31
Figure 10:	Setting down with a forklift truck	31
Figure 11:	Lifting and parking with a crane	32
Figure 12:	Transport shackle (4 x)	32
Figure 13:	Suction nozzle	34
Figure 14:	Terminal box	35
Figure 15:	CEE plug	35
Figure 16:	Components and controls	36
Figure 17:	Height setting	37
Figure 18:	Tilt setting	37
Figure 19:	Making the chip flap accessible	38
Figure 20:	Stop position	38
Figure 21:	Press the safety catch	38
Figure 22:	Extended range	38
Figure 23:	Locking on right side	38
Figure 24:	Locking on left side	38
Figure 25:	Safety switch	38
Figure 26:	Height setting wheel	39
Figure 27:	Tilt setting wheel	39
Figure 28:	Saw shaft with flange and clamping nut	39
Figure 29:	Fitting the circular saw blade	39
Figure 30:	Adjusting the riving knife	40

Figure 31: Fitting the saw blade guard..... 40

Figure 32: Adjusting the saw blade guard..... 40

Figure 33: Loosen the scoring saw shaft clamping nut 41

Figure 34: Inserting a scoring saw blade 41

Figure 35: Socket spanner for setting 42

Figure 36: Set the scoring saw blade..... 42

Figure 37: Mounting and adjusting the cross-cut carriage 43

Figure 38: Mounting and adjusting the telescopic cross-cut fence 44

Figure 39: Angular grid..... 44

Figure 40: Indexing template (right) 44

Figure 41: Check and readjust the tape measure 45

Figure 42: Operating the sliding table..... 45

Figure 43: Mounting the rip fence 46

Figure 44: Operating the rip fence 47

Figure 45: Mounting the table extension..... 48

Figure 46: Height adjustment screws..... 48

Figure 47: Mounting the extension table..... 48

Figure 48: Eccentric clamping device 49

Figure 49: Clamping shoe 49

Figure 50: Push stick..... 49

Figure 51: Operating switches of the machine 50

Figure 52: Overhead guard 54

Figure 53: Open the service door..... 60

Figure 54: Tension drive belt..... 60

Figure 55: Checking the belt tension..... 60

Figure 56: Electrical circuit diagram 62

Revisions:

Revision	Editor	Modification	Date
0	AG	Original manual translated	06.09.2022

1 Liability and Warranty

When purchasing a machine or additional component (hereinafter referred to as “machine”), the General Terms and Conditions of Sale and Delivery of HOKUBEMA Maschinenbau GmbH generally apply. These are provided to the purchaser or operator at the latest when the contract is concluded.



IMPORTANT NOTE: Liability and warranty claims shall only commence from the point in time at which the signed handover certificate (see ⇒ page 3 resp. 5) from the dealer and/or end customer for the delivered machine has been submitted to HOKUBEMA Maschinenbau GmbH in written form.

Liability and warranty claims for personal injury and property damage are generally excluded if they are due to one or more of the following causes:

- Commissioning of the machine without prior machine instruction by an authorised and adequately trained specialist who is familiar with the function and dangers of the machine.
- Electrical connection as well as repair and/or maintenance work on electrical components by personnel who do not have the appropriate qualifications.
- Connection and repair and/or maintenance work on hydraulic or pneumatic components by personnel who do not have the appropriate qualifications.
- Non-observance of the instructions in the operating manual, in particular the chapter “Safety”.
- Improper use or operation in an unauthorised area of application.
- Improper assembly, commissioning, operation and maintenance of the machine.
- Unauthorised conversions or modifications to the machine or additional components.
- Operating the machine without using all the protective equipment available for the operation.
- Inadequate monitoring and maintenance of the machine components and protective devices.
- Continuing to operate the machine when faults, damage or defects are present.
- Processing materials that do not correspond to the machine's area of application.
- Carrying out operations that are not permitted for the machine supplied.
- Use of tools that are not permitted for the machine supplied.
- Operating the machine outdoors or in damp, wet or potentially explosive environments.
- Operation of the machine outside permissible ambient temperatures or humidity.
- Grossly negligent behaviour when handling or operating the machine.
- Impact by foreign bodies, e.g. stones, metal parts, etc.
- Improperly carried out repairs.
- Catastrophic events due to force majeure.

2 Introduction

This operating manual applies exclusively to the WOODPECKER sliding table saw type FKS 6-315/2300. The purpose of this document is to acquaint the user with the machine and enable him to use it to the full extent of its intended capabilities.

Additionally it contains important information to operate the machine safely, properly and economically. Observance of the manual helps to avoid hazards, reduce repair costs and downtimes and increase the reliability and service life of the machine.



Figure 1: Circular saw blade with guard

Furthermore, this operating manual serves to supplement instructions based on national regulations for accident prevention and environmental protection.



This operating manual must always be available at the place of use of the machine. It must be read and followed by every person who is assigned to work on the machine, e.g.

- *during operation, including set-up, troubleshooting in the work process, removal of production waste and maintenance,*
- *during maintenance (servicing, inspection, repair)*
- *and/or during transport.*

Apart from the operating manual and the legally binding accident prevention provisions applicable in the country and place of use, the recognized technical regulations for safe and proper work must also be observed.

2.1 Legal Notice

WOODPECKER is a brand of Hokubema Maschinenbau GmbH. All contents of these operating instructions are subject to the rights of use and copyright of HOKUBEMA Maschinenbau GmbH. Any reproduction, modification, further use and publication in other electronic or printed media, as well as their online publication, requires the prior written consent of HOKUBEMA Maschinenbau GmbH.

2.2 Figures













All photos, figures and graphics contained in this document are for illustration and better understanding only and may differ from the current state of the product. Title photos and general views may also include optional components and special accessories.

3 Symbols

3.1 General Symbols

Symbol	Meaning
	Indicates passages within this operating manual that must be particularly observed in order to prevent malfunctions or damage to the machine.
	Refers to chapters, sections, or figures within this document.
	Refers to an external document or a third-party source.

3.2 Symbols in Safety Instructions

Symbol	Safety Instruction
	General danger symbol, which requires the highest attention! <i>Failure to observe may result in damage to the equipment, serious injury or even death.</i>
	Warning of possible danger from forklift traffic! <i>Non-observance may result in life-threatening injuries.</i>
	Warning indicates a possible hazard under suspended loads! <i>Non-observance may result in life-threatening injuries.</i>
	Warning indicates a possible fall hazard! <i>Non-observance of these instructions may result in serious injuries.</i>
	Warning indicates a possible cutting hazard! <i>Risk of personal injury and possibly additional damage to equipment.</i>
	Reference to the obligation to wear protective gloves! <i>Non-observance of these instructions may result in personal injury.</i>
	Reference to the obligation to wear hearing protection! <i>Non-observance of these instructions may result in personal injury.</i>
	Reference to the obligation to wear protective goggles! <i>Non-observance of these instructions may result in personal injury.</i>
	Reference to the obligation to wear a respiratory protection mask! <i>Non-observance of these instructions may cause breathing difficulties and lung damage.</i>
	Reference to the obligation to wear safety shoes! <i>Non-observance of these instructions may result in personal injury.</i>
	Possible dangerous crushing hazard in the area of stationary objects! <i>Risk of personal injury and possibly additional equipment damage.</i>
	Reference to a possible crushing hazard! <i>Non-observance increases the risk of injury to hands and fingers!</i>
	This symbol warns of the dangers of electric voltage! <i>Failure to observe may result in damage to the equipment, serious injury or even death.</i>
	Fire hazard! Do not smoke and do not ignite open fire.
	Access for unauthorized persons prohibited! <i>Risk of personal injury and possibly additional equipment damage.</i>
	This safety notice indicates a possible dangerous pull-in hazard! Wearing loose clothing, jewellery as well as long untied hair is prohibited! <i>Risk of personal injury and possibly additional damage to property.</i>

4 General

The WOODPECKER “FKS 6-315/2300” sliding table saw is a sturdily constructed and generously equipped machine. With its extra-strong saw unit guided on both sides, it is suitable for professional woodworking in any workshop, joinery or training centres.

Special highlights in the basic equipment are the smooth-running and precise sliding table, the removable cross-cut carriage for processing large panels, the 1500 mm long telescopic cross-cut and mitre fence with two flip stops (extendable up to 2800 mm), the eccentric clamp device that can be mounted in both grooves of the sliding table, the solid and finely adjustable rip fence with extension table as well as the supplementary table extension.

- The circular saw unit has a powerful 4.0 kW / 5.5 HP three-phase motor equipped with a wear-free electronic motor brake. An even more powerful motor with 5.5 kW / 7.5 HP is optionally available.
- The motor shaft has a diameter of 30 mm and allows circular saw blades with min. 250 mm and max. 315 mm diameter to be mounted.
- The circular saw blade can be tilted backwards by up to 45° via handwheel with reading scale and can completely be retracted under the table top if required.
- The planed table top is 800 mm wide and 550 mm long and can be extended to the left with the table extension mounted and the extension table to the rear.
- The precise sliding table is made of aluminium and hardened steel guide rods. It is lockable and allows cutting lengths of up to 2300 mm. Two integrated T-slots can be used to mount the eccentric clamping device supplied, the clamping shoe and/or other aids.
- With the 0.75 kW scoring unit installed (option), the maximum cutting length is 2200 mm.
- With the removable cross-cut carriage, even large panels can be ideally supported and processed.
- The telescopic cross-cut fence can be extended up to 2800 mm and has two flip stops and a millimetre scale. In combination with the cross-cut carriage, it also allows angular cuts that can be set in a few simple steps using an angular grid on the cross-cut carriage.
- The 800 mm long rip fence, which can be finely adjusted to 0.1 mm, allows cutting widths of up to 950 mm when the extension table is mounted. The stop profile can be turned 90° from high to flat so that even flat and narrow workpieces can be machined without obstructions. If the rip fence is not needed, it can be practically folded away.
- The fixed speed of the motor shaft is 4000 rpm and of the optional scoring unit 8000 rpm.
- The saw blade height is adjusted via the hand wheel at the front.
- The saw blade tilt can be adjusted up to 45° via the side hand wheel and angle scale.

4.1 Intended Use

The WOODPECKER FKS 6-315/2300 sliding table saw is designed for cutting materials for which the saw blade used is suitable (e.g. wood, chipboard, veneer, plastic or similar materials). This sliding table saw is not suitable for cutting metal as well as plastics and waste wood in which nails, screws and other metal parts could be contained. The machine may only be operated on a level, fixed surface with a minimum load capacity of 1,000 kg/m².



Improper use can lead to danger to persons and to a defect or damage to the machine.

The sliding table saw is suitable for the following operations:

- Longitudinal cutting of workpieces made of solid wood
- Cross cutting of workpieces made of solid wood
- Cutting of solid or veneered panels

4.2 Target Group and Previous Experience

This operating manual is intended for the operating and maintenance personnel of the machine. The operating personnel is to be determined by the operator and must further meet the following requirements:

- Basic technical knowledge (e.g. apprenticeship as carpenter, machine fitter, etc. and/or practice in operating sliding table saws resp. woodworking machines)
- Reading and understanding these operating and maintenance instructions

In order to acquire the knowledge required to operate this machine, the operator must ensure the following measures:

- Product training for every operator (also possible external personnel)
- Regular safety instruction

4.3 Requirements for the Operators

- The sliding table saw may only be operated by trained personnel who have also read this manual.
- Inspection, maintenance, cleaning and repair may only be performed by technical specialists with product-specific training and mechanical and/or electrical training.
- Specialists with product-specific training are to be commissioned and held responsible for planning and checking the work.
- The national protective regulations for employees must be observed.
- The operator is responsible for the safe use of the machine.
- The legal minimum age must be observed.

4.4 Training of Personnel

All machine operators must be adequately trained in the operation and maintenance of the machine. In particular, the training must include the following:

- General rules for the use of the machine, proper operation, correct setting of the machine, fences and stop systems, the sliding table, cross-cut carriage and all guards.
- Proper handling of the workpieces during the machining process. Correct position of the hands on the workpiece and to the rotating tool during and after machining.
- The personnel must be informed about hazards, risks and appropriate protective measures.
- The personnel must be trained in the area of regular checks of the guards and protective devices.
- The personnel must be trained in the use of the guards and protective device.

4.5 Accident Prevention

To avoid accidents, the following rules must be observed for operation:

- Prevent unauthorized persons from gaining access to the machine.
- Keep unauthorized persons away from the danger areas.
- Repeatedly inform present other persons about existing residual risks (refer to section ⇒ 5.4).
- Conduct and record regular training & instruction for persons who must be in the area of the machine.
- New employees must be trained internally to work on a thickener and this training must be documented.

4.6 General Safety Regulations

In general, the following safety regulations and obligations apply when handling the sliding table saw:

- A sliding table saw may only be operated in a technically perfect and clean condition.
- It is prohibited to remove, modify or bypass any protective, safety or monitoring equipment.
- It is forbidden to modify or alter the machine without the written approval of the manufacturer / supplier.
- Faults or damage must be reported to the operator immediately, eliminated without delay and repaired if necessary.
- For repairs, only original spare parts may be used.
- All protective, safety and monitoring devices must be regularly checked and maintained by the operator.
- Only instructed, trained or qualified persons may work on this machine.
- Maintenance work must be carried out and documented in accordance with the maintenance instructions.
- After maintenance or repair, the machine may only be started with all protective devices fitted. A responsible person must be defined for this purpose, who checks that the guards have been properly installed.
- For the operation of a sliding table saw, the respective national safety regulations for employees as well as the national safety and accident prevention regulations apply.

4.7 Structure and Function

- FKS 6-315/2300 sliding table saw with tiltable saw blade 0 ... 45°.
- Table top size 800 x 550 mm (extendable to the left and back)
- Cutting width at rip fence 950 mm (with extension table)
- Cutting height at 90°: max. 102 mm (with Ø 315 mm saw blade)
- Cutting height at 46°: max. 72 mm (with Ø 315 mm saw blade)
- Cutting length / sliding table length 2300 mm

The circular saw shaft is driven by a three-phase motor with a fixed speed of 4000 rpm.

The circular saw shaft (30 mm Ø) accommodates saw blade diameters from min. 215 mm to max. 315 mm.

The height and tilt of the saw blade are adjusted by two handwheels. The sliding table made of special aluminium profiles runs on hardened steel guide rods. The cross-cut carriage is inserted into the lateral groove of the sliding table, fixed in place by two clamping levers and is also supported by a strong telescopic swivel arm. The telescopic cross-cut fence has a continuous scale and two adjustable flip stops. It can be used in combination with the eccentric clamping device and on the cross-cut carriage.

The rip fence with quick clamping and fine adjustment can be set to any dimension up to 950 mm.

The main switch is lockable. An emergency stop button is fitted at both working positions.

4.8 Standard Equipment

- Saw motor 4.0 kW (5.5 HP) with fixed speed 4000 rpm
- Saw blade guard with suction nozzle
- Sliding table with 2300 mm cutting length
- Removable cross-cut carriage with angular grid for mitre cuts
- Cross-cut fence on cross-cut carriage with mm scale, telescopic extension up to 2800 mm and two robust movable flip stops
- Height and tilt of the saw blade adjustable via handwheels
- Cross-cut fence can be used as angular mitre fence $\pm 45^\circ$ on both sides
- Solid rip fence, manually adjustable with fine adjustment and reversible stop profile (high/flat), including extension table for cutting widths up to 950 mm
- Mountable table extension for long and large workpieces
- Electronic, wear-free motor brake
- Eccentric clamping device for workpiece fixation
- Adjustable riving knife up to Ø 315 mm on the saw blade
- Adjustable clamping shoe as anti-kickback device
- Saw blade can be completely retracted under the table top
- Suction nozzle Ø 120 mm on machine body, Ø 60 mm on saw blade guard
- Push-button control for the saw unit (start/stop)
- Push stick

4.9 Options and Accessories

Various accessories and optional components are available for the FKS 6-315/2300 sliding table saw. These can be used to expand the machine individually.

Detailed information and the corresponding article numbers can be found in chapter ⇨ 16.

5 Safety

5.1 Basic Safety Instructions

Woodworking machines can be dangerous if used improperly. Therefore, observe the safety instructions listed in this chapter and the accident prevention regulations of your employer's liability insurance association!

	<i>The manufacturer accepts no liability for damage and malfunctions resulting from failure to observe these operating instructions.</i>
--	---

5.2 Application Area and Intended Use

	<p><i>The sliding table saw WOODPECKER FKS 6-315/2300 is used exclusively for cutting materials for which the respective saw blade used is suitable (e.g. wood, chipboard, veneer, plastic and similar materials).</i></p> <p><i>This machine is not suitable for processing metal resp. plastic and scrap wood - which could contain nails, screws and other metal parts.</i></p> <p><i>The machine may only be operated on a firm, level surface with a minimum load-bearing capacity of 1,000 kg/m².</i></p>
--	---

Please note: If a suitable saw blade is used, aluminium can also be processed. Any machining of other materials requires prior consultation with the manufacturer and his approval.

Only one-piece (CV) or compound (HM) circular saw blades according to EN 847-1 for manual feed with the following dimensions are permissible as tools:

<i>Saw blade</i>	<i>∅ min.</i>	<i>∅ max.</i>	<i>∅ Bore</i>
Main saw blade	250 mm	315 mm	30 mm H7
Scoring saw blade (option)	-	120 mm	20 mm

You will find circular saw blades as accessories in the section ⇒ 16.1.

	<i>Do not fit saw blades with larger bores! In addition, do not use reducing or adapter rings to adapt larger bores to the shaft.</i>
--	--

The machine is not suitable for operation outdoors or in potentially explosive areas.

- Permissible altitude: max. 1000 m above sea level
- Permissible ambient temperature: +1 ... +40° C
- Permissible humidity: max. 90 %

Intended use also includes the connection of the machine to an adequately dimensioned extraction system (see section ⇒ 7.6) and compliance with the operating, maintenance and servicing conditions specified in the operating manual. Any other use is not in accordance with the intended use and is therefore prohibited.

	<i>Improper use can lead to danger to persons and to a defect or damage to the machine.</i>
--	--























5.3 Modifications and Conversions to the Machine











	<i>Unauthorised conversions and modifications to the machine are strictly prohibited for safety reasons. This will invalidate the CE declaration of conformity! The manufacturer is not liable for any resulting damage. The risk for this is borne exclusively by the operator/user.</i>
--	--

5.4 Residual Risks

The machine is built according to the latest state of the art and the recognised safety rules. Nevertheless, the use of the machine may cause danger to life and limb of the user or third parties or damage to the machine and other equipment.

Due to the construction of the machine, the following residual risks can occur even when used as intended and despite compliance with all relevant safety regulations:

	Reading and applying the operating manual is mandatory for the operating personnel.
	Be alert to possible crushing hazards: a) when transporting the machine by forklift truck → between forks & pallet / machine b) when picking up the machine → between machine / pallet and floor c) when lowering the machine → between machine and fixed equipment
	Be alert to possible crushing hazards when lowering the machine (from the cargo pallet to the floor) with a forklift truck or overhead crane.
	Make sure that no objects fall from the forklift truck / crane. Do not leave any objects / tools on the machine.
	It is strictly prohibited to ride on the machine during a lifting operation (with the indoor crane or forklift). There is a danger of falling!
	Unauthorised persons are not allowed to enter the installation area of the machine (responsibility of the operator).
	Be aware of the danger of cutting at the saw blade. Never reach into the running saw blade! Always wear protective gloves when changing a saw blade.
	The saw blade guard must be used during every cutting operation. Cutting without using the saw blade guard is strictly prohibited. The wearing of protective goggles is mandatory.
	Be aware of the danger from falling objects such as workpieces, tools or similar. Therefore, wear safety shoes, especially when transporting and setting down the machine.
	Be aware of the risk of injury from flying tool parts in the event of tool breakage. Therefore wear protective goggles.
	Be aware of the risk of injury from flying workpiece parts and chips, splinters and dust coming out of the machine. Therefore wear protective goggles.
	Be aware of the increased noise emission and wear hearing protection.
	Be aware of the increased dust generation. Use the extraction device and wear a dust mask if necessary.
	Be aware of a possible danger of being drawn in by moving machine parts or tools. This can cause pieces of clothing or hair to be caught. Always wear tight-fitting clothing or avoid loose clothing and wear a hair net if necessary.
	Danger of being drawn in and increased risk of injury when wearing watches and jewellery. Wearing watches and jewellery is prohibited on the tilting spindle moulder.
	Never reach into the area between the saw blade guard and the aluminium profile rail (cross-cut fence). There is a danger of crushing!
	Electrical equipment must be maintained and cleaned regularly.
	The saw blade guard for mitre cutting (inclined saw blade) is wider and can therefore be reached earlier by the profile rail. Therefore the danger of splintering exists earlier.
	Danger from electric shock! It is strictly forbidden to bypass safety devices (e.g. safety switches).
	Danger from electric shock! There are hazards when working on the electrical system. This work must only be carried out by qualified personnel!
	Be aware of the crushing hazard when closing the saw blade guard and the cutting hazard at the saw blade.
	Be aware of the risk of crushing between the sliding table and the holding block for the saw blade.

	Be aware of the risk of crushing at the end of the running rail for the sliding table between the running rail and the sliding table.
	Pay attention to the risk of crushing on the inside of the sliding table on fixed components / guide rods on the inside of the sliding table.
	Be aware of the risk of crushing when pushing the sliding table forward between the sliding table and the front holding block for the saw blade.
	Do not stand between the cross-cut fence and the telescopic swivel arm (when pushing the sliding table forwards or backwards). There is a danger of crushing (it is forbidden for the operator and third persons to stay in this area).
	Pay attention to the danger of crushing in the area of the support for the cross slide (at the swivel arm). Reaching into this area is prohibited!
	Do not reach into the area between the rip fence and the ruler bar (especially when pushing back the rip fence).
	Pay attention to the danger of cutting and crushing in the area of the scoring saw blade. Access during normal operation and by unauthorised persons is strictly prohibited.
	Make sure that no unauthorised persons are in the area of the machine.
	Be aware of the risk of crushing between the sliding cross-cut fence and the cross slide on both sides: Do not reach into these areas!
	The emergency stop buttons must always be freely accessible. They must not be moved, e.g. with hopper boxes. Check the function of the emergency stop buttons daily (before starting work).
	Fire hazard due to wood dust in connection with flying sparks and/or open fire!

5.5 Observe the Environmental Protection Regulations

During all work with the machine, the environmental protection regulations, obligations and laws for waste avoidance and proper recycling and/or disposal applicable at the place of use must be observed. This applies in particular to installation, repair and maintenance work involving substances that could pollute the groundwater (e.g. hydraulic oils and cleaning agents and liquids containing solvents). In any case, prevent them from seeping into the ground or entering the sewage system.

	<i>Store and transport the above-mentioned hazardous substances only in suitable containers. Avoid leakage of hazardous substances by using suitable collection containers. Ensure that the above-mentioned substances are disposed of by a qualified disposal company.</i>
---	--

5.6 Organisational Measures

- ⚠ Always keep this operating manual within easy reach and at the place of use of the machine.
- ⚠ In addition to the operating manual, observe and instruct on generally applicable legal and other binding regulations for accident prevention and environmental protection.
- ⚠ Supplement the operating manual with further instructions, including supervisory and reporting duties, to take account of special operational features (e.g. with regard to work organisation, work processes, personnel employed).
- ⚠ Operators must not wear open long hair, loose clothing or jewellery (including rings). There is a risk of injury, e.g. by getting caught or drawn in.
- ⚠ Observe the safety instructions and danger warnings on the machine and keep them complete and in legible condition.
- ⚠ In case of safety-relevant changes to the machine or its operating behaviour, shut down the entire system immediately and report the fault to the responsible office/person.
- ⚠ Spare parts must meet the technical requirements specified by the manufacturer. The exclusive use of original spare parts ensures this. Therefore, only use original spare parts from the manufacturer.
- ⚠ Observe the fire alarm and firefighting possibilities. Make the location and operation of fire extinguishers (fire class ABC) known. Do not use water!

5.7 Personnel Selection and Qualification - Basic Duties

- ⚠ The machine design and operation is intended for right-handers.
- ⚠ Work on and with the machine may only be carried out by reliable personnel. Observe the legal minimum age!
- ⚠ Only use trained or instructed personnel. Clearly define the responsibilities of the personnel for operating, setting up, maintaining and repairing!
- ⚠ Ensure that only authorised personnel work on the machine!
- ⚠ If personnel to be trained or apprenticed have to work on the machine, this may only be done under the constant supervision of an experienced resp. qualified person.
- ⚠ Work on the electrical equipment of the machine may only be carried out by a qualified electrician or by untrained persons under the direction and supervision of a qualified electrician in accordance with the electrotechnical regulations.

5.8 Safety Instructions for Specific Phases of Operation

5.8.1 Normal Operation

- ⚠ Refrain from any working method that could compromise safety!
- ⚠ Take measures to ensure that the machine can only be operated in a safe and functional condition.
- ⚠ The machine may only be operated when all protective devices and safety-related equipment, such as e.g.:
 - Detachable safety devices
 - Emergency stop system
 - Sound insulation
 - Extraction unitare present and functional.
- ⚠ Check the machine at least once per shift for externally visible damage and defects!
- ⚠ Report any changes that have occurred (including changes in operating behaviour) immediately to the responsible office or person! If necessary, stop the machine immediately and secure it!
- ⚠ Adjust the cutting angle and cutting height only when the saw blade is stationary.
- ⚠ An obstacle-free working area around the machine is essential for safe operation.
- ⚠ The floor should be level, well maintained and free of debris such as chips and cut workpieces.
- ⚠ The workplace should be adequately lit by general or local lighting.
- ⚠ Never try to remove cuttings, chips or other parts from the cutting area while the machine is running!
- ⚠ Inspect the workpiece for foreign inclusions, knots, twists and other irregularities.
- ⚠ Switch off the machine even during short work interruptions!
- ⚠ Switch off the control voltage and main switch before leaving the machine. Never leave the machine unattended in an unsecured state.

5.8.2 Special work within the Scope of Maintenance Work as well as Troubleshooting in the Workflow

- ⚠ Observe maintenance and inspection activities prescribed in the operating manual!
- ⚠ These activities, as well as all other repair work, may only be carried out by qualified personnel!
- ⚠ For all work concerning operation, production adjustment, conversion or setting of the machine and its safety-related equipment as well as maintenance and repair, observe switch-on and switch-off procedures according to the operating manual and instructions for maintenance work!
- ⚠ Secure the machine against unexpected restarting during maintenance and repair work.
 - Lock the main switch with a padlock!
- ⚠ Always tighten screw connections that have been loosened during maintenance and repair work!
- ⚠ If it is necessary to dismantle safety equipment during set-up, maintenance and repair, the safety equipment must be reassembled and checked immediately after completion of the maintenance and repair work!
- ⚠ Ensure safe and environmentally friendly disposal of operating and auxiliary materials (e.g. oils) and replacement parts (e.g. electronic components)!

5.9 Safe Working Practices

- Whenever possible, a push stick must be used to prevent working with the hands close to the saw blade. Observe the danger zone of 120 mm around the saw blade. See also section ⇒ 5.10 “Hazardous Areas on the Sliding Table Saw”.
- Always work with all available guards and protective devices! These must be accessible at the right places and in perfect working order.
- Working position: Always to the side of the saw blade, outside a possible kickback area (= area directly in front of the saw blade). See also section ⇒ 5.10 “Hazardous Areas on the Sliding Table Saw”.
- Do not start cutting until the saw blade has reached full speed.
- Set the distance between the saw blade and riving knife to 3 - 8 mm as evenly as possible.
- The riving knife must not be thicker than the kerf width and not thinner than the saw blade body.
- Only use saw blades suitable for the respective operation.
- Do never use damaged saw blades.
- A detachable feeding unit should be used whenever possible. This must be equipped with a separate on/off switch.
- A removable feeding unit is not a substitute for the riving knife. The riving knife must always remain installed.
- When using a feeding unit, there must be sufficient space on the removal side in front of stationary obstacles (danger of crushing by the workpiece!).
- The use of the sliding table saw for cutting rebates, tenons or grooves is prohibited unless the part of the saw blade above the table is effectively secured.
- For “insert cutting”, suitable anti-kickback devices must be fitted. The riving knife has to be removed and the holder has to be fixed.
- The height of the saw blade guard should be placed as close as possible to the workpiece without touching it.
- Concealed cutting may only be carried out with a mounted overhead saw blade guard (option).
- When cutting concealed, use aids such as an auxiliary fence and a push handle.
- The riving knife must not be removed during “concealed cutting”.
- Grooving (concealed cutting) with a grooving cutter is prohibited on this machine, as no grooving cutters are approved for this machine.
- If a second person is working at the sliding table saw to remove processed workpieces, this person must not stand at any other place than at the end of the table extension.
- When trimming and ripping, mount the clamping shoe on the removal side of the sliding table to hold down the workpiece and fix it on the feed side with the eccentric clamping device.
- For cutting narrow and low batten, tilt the aluminium stop rail of the rip fence by 90° so that the narrow contact edge can be used.
- For cross-cuts, use the cross-cut carriage with cross-cut fence.
- Make angle and mitre cuts only with the cross-cut carriage mounted on the sliding table.
- Use a deflector wedge for cutting small pieces.
- Replace damaged table inserts immediately with new ones.
- When cutting narrow workpieces < 120 mm, use the push stick.
- For cutting widths < 30 mm, use an adequate push block.
- Use a wedge cutting jig for cutting wedges.
- Repairs may only be carried out by qualified personnel with the main switch locked.
- The machine must be connected to an effective extraction system. or this, an extraction capacity of 1800 m³/h at a flow rate of at least 25-30 m/s is required.
- The machine is equipped with an electronic motor brake. If the motor brake no longer brakes within the prescribed braking time (10 s), the customer service must be informed immediately.

5.10 Construction-related Safety Equipment

- Together with the saw blade guard, the riving knife is one of the most important safety devices on the sliding table saw. It prevents the saw blade from jamming in the kerf and thus prevents dangerous workpiece kickbacks and ejection of the workpiece and/or workpiece parts.
- The saw blade guard is mounted on the riving knife and has a suction nozzle for connecting the extraction system on the top. The saw blade guard thus ensures effective extraction of chips and sawdust as well as effective saw blade protection.
- The smooth-running and lockable sliding table ensures safe workpiece guidance. Even large workpieces can be safely processed, trimmed and ripped. The integrated locking device in combination with the cross-cut carriage prevents dangerous workpiece kickbacks during insertion cutting.
- The cross-cut fence, which can be mounted on either side of the cross-cut carriage, ensures that the workpiece is securely fixed. It has two adjustable flip stops, a millimetre scale for exact dimension setting and a fixed 90° lock. In addition, angles in the range of $\pm 45^\circ$ can be set.
- The rip fence is equipped with a solid stop profile that can be moved in the cutting direction. It can be retracted so far that jamming of cut-off workpiece parts between the fence and the rising teeth is avoided. For machining flat and narrow workpieces, or when the saw blade is tilted, the ruler can be turned from the high to the flat position.
- The clamping shoe and the eccentric clamping device included in the scope of delivery are used to clamp and hold down unedged solid wood (e.g. boards) on the sliding table. It ensures effective kickback protection and secures the workpiece during edge trimming.
- The saw unit can be completely retracted under the machine table with the saw blade guard removed.
- The push stick included in the scope of delivery ensures safe guidance for narrow workpieces (< 120 mm) during the final phase of the cut and keeps the hands out of the danger zone of the circular saw blade.
- The circular saw blade and optional scoring saw blade are fixed by means of pressure flanges. Their integrated keyways ensure that the saw blade does not come loose by itself when the machine is stopped.
- The clockwise rotating main saw blade is secured against loosening of the clamping nut by a left-hand thread. The optional scoring saw blade (counterclockwise rotation) is secured by a conventional right-hand thread.
- The correct directions of rotation for the main and scoring saw blades are marked on the saw blade guard and on the chip flap by arrow stickers.
- The extension table (rear) and the table extension (left) ensure a secure workpiece support even with large workpieces.

5.11 Electrical Safety Equipment

- Lockable main switch: The main switch can be locked with a padlock to protect the machine from unintentional or unauthorised restarting (e.g. during adjustment, repair and maintenance work).
- The sliding table saw is equipped with two emergency stop buttons (on the control panel and on the right-hand side of the machine below the rip fence). This allows the machine to be stopped immediately in the event of danger. The emergency stop switches must always be freely accessible and must not be blocked with wood or other objects.
- The chip flap is equipped with a safety switch. This has the effect that the power supply to the main motor is switched off as soon as the chip flap is opened.
- Electronic brake for electrodynamic braking of the drive motors: This ensures that the circular saw blade comes to a standstill in less than 10 seconds after the motor is switched off.
- Undervoltage protection: In the event of a voltage interruption, the machine is brought to a standstill, where it remains even when the voltage is restored. To restart it, it must be switched on again.
- Protection against electric shock: The housing of the machine and the drives are protected against electric shock with a neutral line.
- Dust protection: The control cabinet and the drive unit(s) are protected against contact, dust and splash water on all sides with IP54 protection.
- Short-circuit protection: The machine has overload protection for the motor (thermal cut-out switch).

5.12 Hazardous Areas on the Sliding Table Saw

	<p>Carry out adjustment work within the danger zones only when the saw blade is stationary!</p>
--	--

5.12.1 Danger Zone Saw Blade

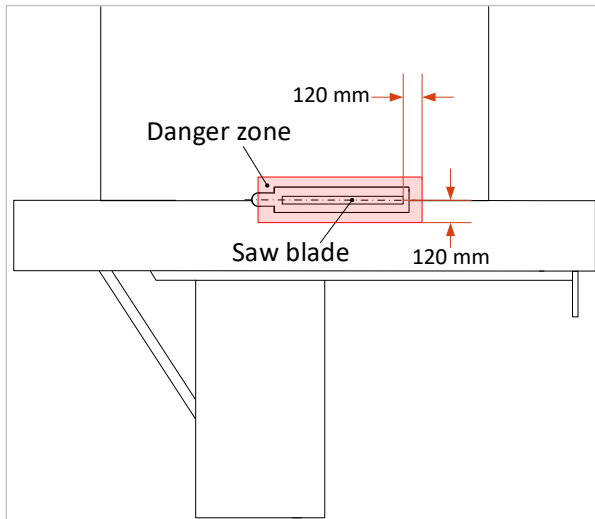

Figure 2: Danger zone saw blade

- The area 120 mm around the saw blade is considered to be a danger area with an increased risk of injury.
- Hands must never be within this danger zone when the saw blade is running!
- Never remove chips and parts lying around with your hands!
- Within the danger zone, use a push stick, push block or other suitable aid for feeding.
- When feeding the workpiece manually, place your hands flat with your thumbs on them and do not spread your fingers.
- Lower the saw blade guard before starting work.

	<p>Be aware of the danger of cutting and being drawn in within the danger zone of 120 mm around the saw blade! Wearing gloves, loose clothing, open hair as well as watches or jewellery is prohibited when working on the sliding table saw!</p>
--	--

5.12.2 Danger Zones around the Machine

Another danger zone is located in front of the machine within the feed area of the saw blade. Here, there is a particular risk of serious injury from a material kickback. During operation, the operator as well as any helpers and possible observers must refrain from being in the marked danger zone!

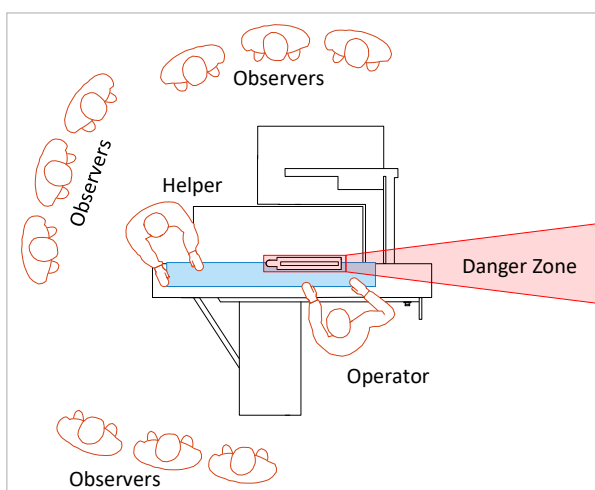

Figure 3: Danger zones around the machine

- The operator of the machine must generally stand at the front of the machine, outside the danger zone (depending on the application, to the left or right of the saw blade (see also section ⇒ 6.3).
- A helper for workpiece removal must generally stand behind the machine and outside the danger zone. The helper must not stand within the movement range of the sliding table.
- Observers must stand in a semi-circle formation outside the danger zone. An adequate distance must be maintained so that the operator of the machine and any helper are not hindered in their work.

	<p>Be aware of the danger of kickback due to ejecting workpieces! Entering the danger zone during the cutting process can lead to serious injuries.</p>
--	--

5.13 Avoidance of Kickback Hazards

Uncontrolled kick-back of workpieces and parts must be prevented with all available means, as these provide a very high hazard potential. The kickback area starts from the centre of the saw blade towards the rear, where the saw teeth rotate in an upward direction. If the rising teeth come into contact with the workpiece or loose boards, battens or blocks lying around, these can be ejected immediately, which can cause the most serious injuries. In this section you will find valuable hints to effectively avoid kickbacks.



Many serious injuries on a sliding table saw occur due to workpieces kicking back. To avoid kickbacks, please observe the following sections.

5.13.1 Use fence and saw blade guard

Increased danger exists (as mentioned above) due to parts lying around that are caught by the rising teeth. Equally dangerous is freehand cutting without a guide, because even a trained carpenter's hand is not able to make an absolutely straight cut. If the cut is slightly skewed, the workpiece can twist on the saw table in such a way that it gets into the area of the rising teeth and can be gripped.

- ➔ Therefore, generally use a fence to guide the workpiece and lower the saw blade guard to just above workpiece height.

5.13.2 Never work without the riving knife

The riving knife is an elementary guarantee of safety. It prevents the kerf from closing again behind the saw blade (especially in the case of material with a lot of tension) and thus from jamming with the rising teeth.

- ➔ Only in very few exceptional cases (e.g. when insert cutting) may the riving knife be removed for the duration of the corresponding operation.

5.13.3 Use anti-kickback devices

Whenever possible, use a front and rear saw aid as an anti-kickback device, for example the clamping shoe supplied in combination with the eccentric clamping device when trimming.

5.13.4 Rip fence when cutting short workpieces to width

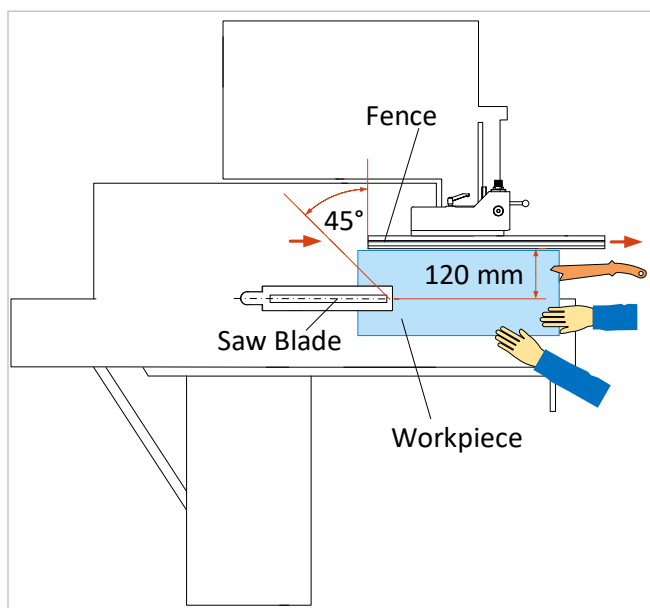

Figure 4: Cutting short workpieces to width

The rip fence must not be set too far towards the saw blade when cutting short workpieces to width. Workpieces that have already been cut can jam between the fence and the saw blade. This is especially dangerous when the workpiece reaches the area of the rising teeth.

- ➔ To move the rip fence out of the danger zone, pull the fence rail back towards the operator's side so that the rear edge of the fence forms an angle of approx. 45° relative to the front edge of the saw blade.
- ➔ For cutting widths < 120 mm, generally use a push stick (see section ⇨ 10.14) and for cutting widths < 30 mm use an adequate push block for feeding.

5.13.5 Parallelism of the rip fence

Regularly check the parallelism of the fence by measuring the front and rear of the machine table. Even a slight deviation of 1 to 2 degrees can press the workpiece against the saw blade in such a way that it jams. Then it can be caught by the rising teeth and trigger a kickback. Ideally, the distance of the fence to the rear (in the direction of the rising teeth) is approx. 0.2 mm higher than in front of the saw blade.

	<p>Danger of kickback due to ejecting workpieces! The distance of the fence in front of the saw blade must never be higher than at the rear in the area of the rising teeth.</p>
--	---

Clear indications that the parallelism of the fence is no longer correct are sluggishness of the workpiece when it is fed, a strong noise development and burn marks on the workpiece. If your fence has been misaligned, please contact our customer service (phone number: 0049 - 7571 / 755-0).

5.13.6 Cutting off small pieces on the rip fence

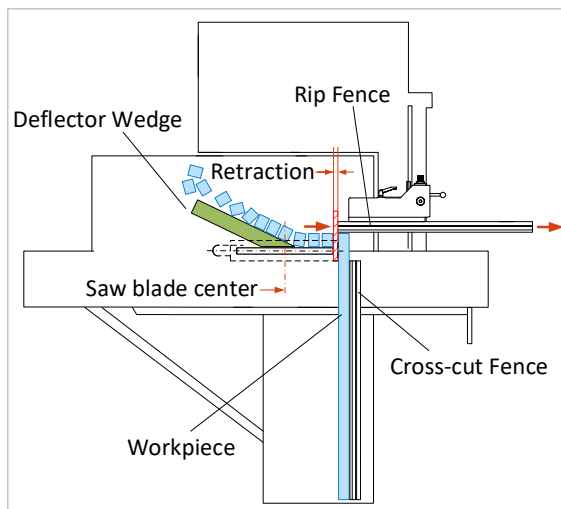

Figure 5: Fixing the deflector wedge on the table

If you are using the rip fence to cut many smaller pieces of identical dimensions from a long piece (which rests against the cross-cut fence), it is important to prevent cut pieces from jamming between the fence and the saw blade and being caught by the rising teeth.

- ➔ To do this, move the rip fence backwards towards the operator's side and fix it so that there is enough space between the fence and the front edge of the saw blade for the retraction (see ⇨ Figure 5).
- ➔ Fix an additional deflector wedge (see ⇨ Figure 5) auf on the table top so that small parts that have already been cut off cannot be caught by the rising teeth and flung upwards.

	<p>Important: The deflector wedge must be fitted so far towards the operator's side that the cut-off parts are already deflected shortly before the centre of the saw blade.</p>
--	---

	<p>Danger of kickback due to ejecting workpieces! Never remove already cut parts by hand and fix a deflector bar on the machine table.</p>
--	---

5.13.7 Insert cutting

When insert cutting (without riving knife and saw blade guard), an anti-kickback device must generally be used, e.g. the clamping shoe front. To do this, insert the clamping shoe into a groove of the sliding table and fix it with the clamping lever. Then secure the sliding table with the locking lever to prevent it from moving.

Important: The riving knife and the upper saw blade guard must be refitted immediately after insert cutting.

6 Machine Data

6.1 Technical Specifications

Saw blade diameter:	min. Ø 215 mm / max. Ø 315 mm
Circular saw shaft:	Ø 30 mm
Shaft speed:	4000 rpm
Length of the rip fence profile:	800 mm
Rip fence capacity:	950 mm (with mounted extension table)
Maximum cutting length:	2300 mm (with optional scoring unit: 2200 mm)
Saw blade tilt range:	0 ... 45°
Maximum cutting height at 0°:	Saw blade Ø 315 mm: 102 mm / Ø 250 mm: 70 mm
Maximum cutting height at 45°:	Saw blade Ø 315 mm: 72 mm / Ø 250 mm: 49 mm
Height of the machine table:	850 mm
Machine table dimensions:	800 x 550 mm
Dimensions of the sliding table:	2300 x 360 mm
Telescopic cross-cut fence:	L = 1500 mm, extendable up to 2800 mm
Suction nozzles:	Ø 60 mm (saw blade guard) und Ø 120 mm (machine body)
Motor power:	4.0 kW / 5.5 HP (optionally 5.5 kW / 7.5 HP)
Motor brake:	electronic, wear-free
Protection class:	IP54
Weight:	approx. 530 kg
Space requirement:	6000 x 8000 mm

Scoring unit (option)

Saw blade diameter:	120 mm
Circular saw shaft:	Ø 20 mm
Motor power:	0.75 kW / 1.0 HP
Shaft speed:	8000 rpm

Name plate:

WOODPECKER
HOKUBEMA GmbH • D-72488 Sigmaringen
Telefon/phone +49(0)7571 755-0

Formatkreissägemaschine

Baureihe line	
Typ type	FSK 6-315/2300
Maschinen-Nr. machine no.	
Baujahr year of construction	202
Bemessungsspannung U = nominal voltage U =	V
Frequenz/Phasenzahl frequency/phases	Hz / 3
Stromart kind of current	AC
Volllaststrom I = operating current I =	A
Überstromschutz, intern excess current protection, internal	A

Manufacturer:

HOKUBEMA Maschinenbau GmbH
Graf-Stauffenberg-Kaserne
Binger Str. 28 | Halle 120
DE-72488 Sigmaringen (Germany)
Tel.: +49 (0) 7571 / 755-0
Fax: +49 (0) 7571 / 755-2 22

Correspondence in the vase of service:

Please, in case of technical problems, contact your dealer or the manufacturer's service department. In correspondence or during a telephone call regarding the purchased machine, you should have the following data at hand:

- Manufacturer number of the machine
- Voltage and frequency
- Date of manufacture
- Detailed description of the fault
- Detailed description of the type of machining carried out
- General operating time of the machine in working hours
- In case of questions regarding the electrical system, the information on the machine's type plate is also required.

Figure 6: Name plate

6.2 Emission Levels

6.2.1 Noise Information

The values given are emission levels and therefore do not necessarily represent safe workplace values. Although there is a correlation between emission and immission levels, it cannot be reliably deduced whether additional precautionary measures are necessary or not.

Factors that may affect the current immission level at the workplace include the duration of exposure, the nature of the workspace, other noise sources, etc., e.g. the number of machines and other activities in the vicinity. The permissible workplace values can also vary from country to country.

However, this information should enable the user to make a better assessment of hazard and risk.

6.2.2 Noise Emission Values

<i>Explanation of noise emission</i>	
Weighted level: Noise pressure in idle state	$L_{pFA} = 79 \text{ dB}$ Uncertainty: $K = 2 \text{ dB}$
Weighted level of noise power at the workplace	$L_{WA} = 108 \text{ dB}$ Uncertainty: $K = 2 \text{ dB}$ at error limit interval 95 %



***The workplace-related noise emission values of the machine exceed 85 dB(A)!
Therefore, suitable hearing protection must be provided to the personnel!***

6.3 Workplace Requirements

The effective space requirement generally depends on the maximum external dimensions of the machine (see next section \Rightarrow 6.4) and the dimensions of the workpieces to be processed. In general, provide sufficient space around the machine and also calculate the required space for the operating and auxiliary personnel as well as for the infeed and outfeed of the workpieces).

- Select a suitable installation site for the machine and consider the working areas shown in the figure.
- Consider the existing hazardous areas (see \Rightarrow 5.10).
- Based on the maximum possible dimensions (see section \Rightarrow 6.4) a clearance of at least 0.8 m must be ensured around the machine.
- Sufficient space must be ensured for the infeed and outfeed of long workpieces
- Sufficient lighting (min. 500 lux) must be ensured. The lighting must not dazzle and a stroboscopic effect must be avoided.
- Make sure that the floor can support the load of the machine. The machine must be levelled at the four adjusting feet simultaneously with a machine spirit level.
- The chosen location must guarantee a suitable connection to the mains supply and to an external extraction system.

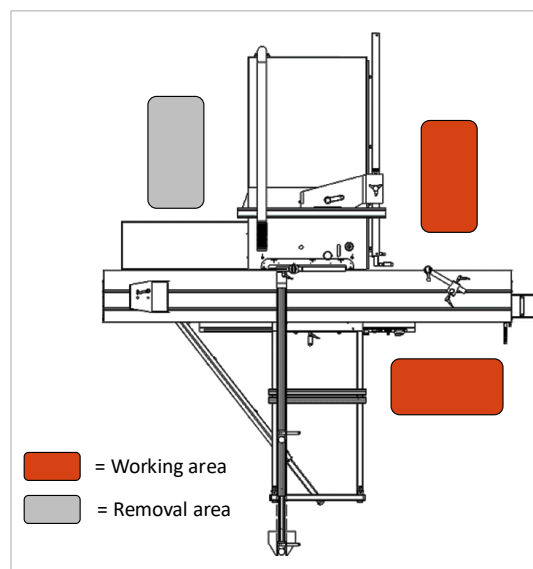

Figure 7: Working areas

6.4 Maximum Dimensions

The external dimensions of the machine are variable, as they depend on the position of the sliding table and the cross-cut fence. The dimensions shown below refer to the maximum achievable state.

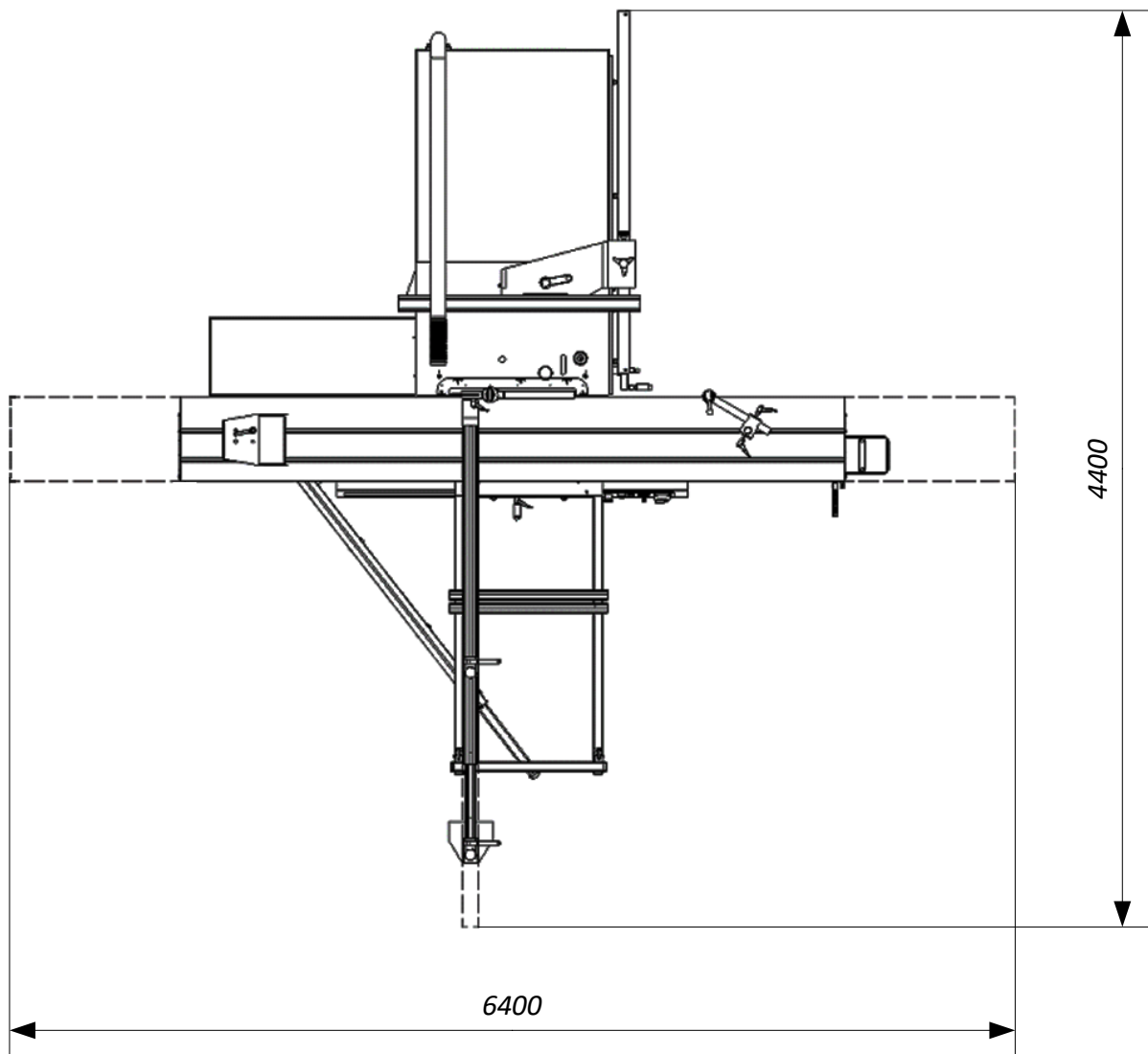

Figure 8: Maximum dimensions - top view

- The dimensions shown are rounded approximate dimensions.
- Subject to design and dimensional changes!

7 Installation and Connection

7.1 Check Delivery Conditions

Check the consignment for completeness and possible transport damage. In case of transport damage, please keep the packaging and inform the shipping company and the manufacturer immediately! Later complaints cannot be accepted.

7.2 Transport

Lifting and transporting the machine must be carried out by qualified persons who have the required experience and equipment.



Please take great care when loading and unloading the machine. The necessary measures must be taken to avoid impacts, damage as well as injuries to persons. When transporting, also pay attention to the existing danger of tipping over!

The machine is delivered on a transport pallet and is bolted to the bottom of the pallet. The centre of gravity of the machine is approximately in the middle of the pallet. The machine may only be transported using suitable aids, e.g. a forklift truck, lift truck or indoor crane with a load capacity sufficient for the weight of the machine (net weight approx. 530 kg).



Danger to life under suspended loads during transport by forklift or crane. Staying under a suspended load is strictly prohibited! In addition, make sure that no objects fall down during transport by forklift / crane. Do not leave loose objects, accessories or tools on the machine.

7.2.1 Unloading with a Forklift Truck

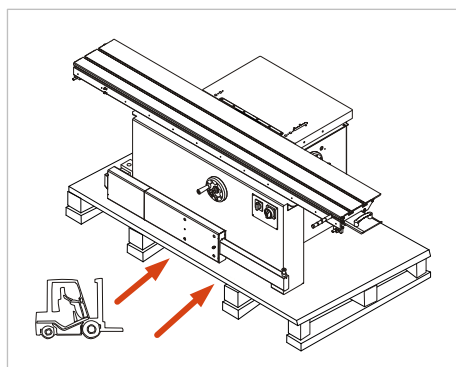

Figure 9: Unloading with a forklift truck



Important! The forks of the forklift truck must be be at least 1200 mm long!

- Move the forks of the forklift truck centrally between the pallet timbers. Then feed the forks of the forklift truck as shown in ⇒ Figure 9.
- Lift the pallet by a few centimetres and move the machine to the immediate vicinity of the installation site.

7.2.2 Setting down with a Forklift Truck

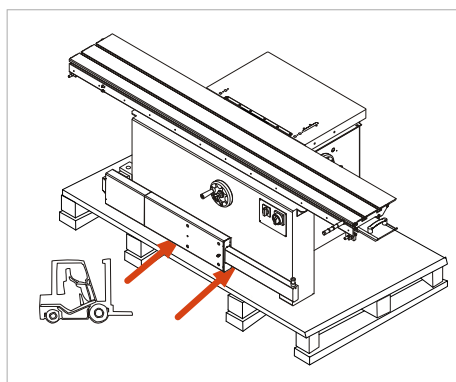

Figure 10: Setting down with a forklift truck



Important! The forks of the forklift truck must be be at least 1200 mm long!

- Remove all the screw fastenings required for transport on the pallet and the four transport shackles (see ⇒ Figure 12) on the machine feet.
- Then lift the machine off the pallet with the forklift truck and feed the forks of the forklift truck as shown in ⇒ Figure 10.
- Now move the machine to the final installation site and park it at the final place of use.

7.2.3 Lifting and Parking with an Overhead Crane

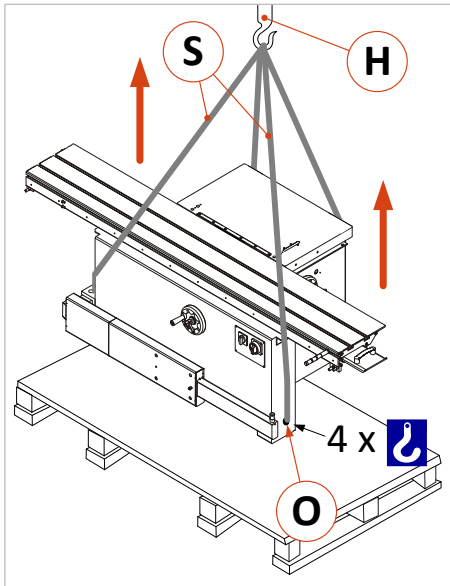

Figure 11: Lifting and parking with a crane

- Prepare four lashing straps or transport ropes (**S**) with the required load capacity and in sufficient length and hang them on the crane hook (**H**) as shown in ⇒ Figure 11.
- Then fasten the straps/ropes (**S**) in the four transport lugs (**O**) of the machine and adjust them well. If necessary, move the crane a little to ensure vertical and stable lifting. Do not tilt the machine!



Before lifting, check that the ropes are securely fastened in the four transport lugs!

- Lift the machine only so far that the pallet can be removed. Proceed carefully and without bumping / rocking.
- Remove the screw fastenings and transport shackles (see ⇒ Figure 12) required for transport on the pallet and fit the four support feet supplied.
- Then park the machine at the intended place of use.

7.3 Machine Installation

Remove the preservative that was applied at the factory to protect the parts against corrosion without painting. This can be done with commercially available solvents. Please do not use nitro solvents or similar solvents and never use water to remove the preservative!

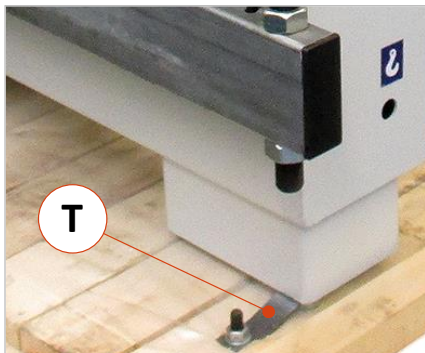

Figure 12: Transport shackle (4 x)

- Due to the solid machine construction, no special foundation is required to ensure good levelling and vibration-free operation of the machine.
- After you have removed all four transport shackles (**T**) on the feet and mounted the levelling supports in the free holes instead of them, the machine must be levelled.
- Use an open-ended spanner to compensate for uneven ground with a machine spirit level 0.1 mm/1 m via the adjusting nuts until a stable and level stand is achieved. Then secure all support feet with the lock nuts.



Be aware of possible crushing hazards when placing the machine (from the pallet to the floor) by means of a forklift truck or similar. Pay particular attention to your hands and feet and wear safety shoes and protective gloves as a precaution.



Danger to life when using a forklift truck! Keep a sufficient distance from the forklift truck and watch its speed. Vehicles with combustion engines also produce toxic exhaust gases. Wear a breathing mask if necessary.



It is essential that the machine is level! Check with spirit level!



Dispose of the packaging material in an environmentally friendly way!



Do not use nitro thinner for cleaning. Painted surfaces of the machine can be damaged.



Fire hazard! Do not smoke and do not light an open fire.

7.4 Temporary Storage

If the machine is not put into operation immediately after delivery, it must be stored carefully in a protected place. Carefully cover the entire machine so that neither dust nor moisture can penetrate.

The bare, non-surface-treated parts are provided with a preservative. This must be checked regularly for effectiveness and renewed if necessary.

7.5 Lashing in a Transport Vehicle

For transport in a transport vehicle, the machine must be bolted to a transport pallet (as on delivery), lashed upright on the vehicle loading surface and properly secured.

The responsibility for safe loading is borne by the respective shipper!

	<p><i>At least two lashing straps must be used, each of which must be individually tensioned on the loading area of the transport vehicle! The palletised machine must be additionally secured against slipping and tipping over in the vehicle.</i></p>
---	---

Please note the following when lashing in the transport vehicle:

- The loading area of the transport vehicle must always be clean and dry.
- The lashing straps used must be suitable for the total weight of the machine (net weight approx. 530 kg).
- For transport, loose assemblies, accessories or tools must be removed from the machine. These can, for example, be individually packed in cardboard boxes and separately lashed to a free area of the pallet (e.g. with another lashing strap).
- For all components remaining on the machine, make sure that the clamping levers and clamping handles are well tightened so that the parts are secured during transport and cannot slip out of place.
- Fastening on the loading area is done by lashing down: This means that the transport pallet is secured by frictional locking. The load is pressed so firmly onto the loading surface that it can no longer slip. The clamping tool should have a high STF value at the frictional connection, e.g. long-lever ratchets.
- In addition, anti-slip mats should be used to provide even more safety.
- The ideal lashing angle (α) for tie-down lashing is 83° to and 90°. Therefore, the lashing straps should pull downwards approx. vertically. As the angle decreases, the pretensioning force of the lashing is reduced.
- When tensioning the lashing straps, make sure that no parts of the machine can be crushed or damaged.
- Observe the permissible total weight of the transport vehicle.
- Ensure that the permissible axle loads of the transport vehicle are observed. The load must be distributed evenly on all axles of the vehicle.

7.6 Connecting the Extraction Unit

- The machine must be connected to an effective extraction system on-site.

Installation only by a qualified electrician!

- The suction nozzle on the saw blade guard has a diameter of 60 mm and the one on the machine body measures 120 mm.
- All parts of the extraction system, incl. hoses, must be included in the earthing measure.

	<p><i>If flexible suction hoses are used, they must be flame-retardant.</i></p>
--	--

- Use one suction hose with a diameter of 60 mm and one with a diameter of 120 mm to connect the extraction system to the two suction nozzles of the machine.

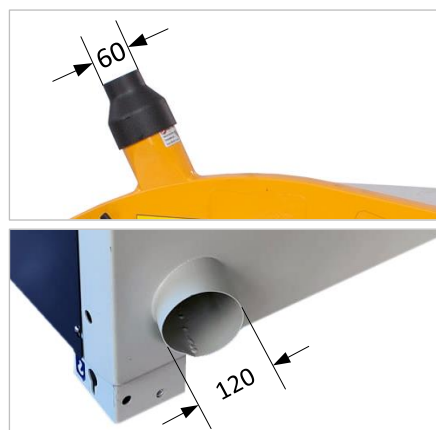

Figure 13: Suction nozzle

- The extraction system for chips and dust must have an extraction capacity of at least 1800 m³/h at a speed of 25 ... 30 m/s.

	<ul style="list-style-type: none"> • <i>The air velocity must be checked before initial commissioning and after significant changes.</i> • <i>The extraction system must be checked <u>daily</u> for obvious defects after initial commissioning and <u>monthly</u> for effectiveness.</i>
--	--

	<p><i>When the machine is switched on, the extraction system must start automatically.</i></p>
--	---

7.6.1 Automatic switching of the Extraction System (Option)

Installation only by a qualified electrician!

With this option, the additional contacts “53” and “54” of the contactor “-K2” are available to connect two signal generator lines for automatic switching of the extraction system.

- Order designation: FSK 6-315-005

See also chapter ⇒ 15 “Electrical Circuit Diagram”.

7.7 Electrical Connection

	<p>The connection must be carried out by an authorized electrician in accordance with the valid local EVU, VDE and EN regulations! Turn main switch to “O” before connecting.</p>
--	--

Please observe the specified nominal voltage 400 VAC / 50 Hz (3 phases / N / PE)!

Depending on the version, the machine can be equipped with a terminal box or a CEE plug.

With the terminal box version, the supply cable is inserted through the cable gland on the underside of the terminal box. This is located on the right-hand side of the machine (see ⇒ Figure 14).

- Use a supply cable as described in section ⇒ 7.7.1 below.
- The connection to the mains (3 phases) is made in the housing of the terminal box. The 3 phase cables must be connected to the terminals marked **L1 / L2 / L3**.
- The protective earth wire (yellow/green) must be connected to the terminal marked **PE**.
- Then close the cable gland again so that it is dust tight.



Figure 14: Terminal box



With the variant with CEE plug, the connection to the mains is made by plugging in an appropriately powered CEE coupling; 380 V / 16 A; phases **L1 / L2 / L3 / N / PE**. Required supply cable see section ⇒ 7.7.1 below.

	<p>The fault loop impedance and the suitability of the overcurrent protection device must be checked at the installation site of the machine.</p>
--	--

Figure 15: CEE plug

Only if the connection is carried out by an authorised electrician can a guarantee be given for the motor. In the event of a complaint, the electrician must confirm in writing that he has connected the machine in accordance with the regulations.

7.7.1 Supply Cable and External Fuse Protection

Use a Cu, 5-core cable. The wire cross section must be determined on site by a qualified electrician!

The electrical cabling and the connection must be performed by a specialist according to the applicable local EVU, VDE, and EN provisions. We recommend the use of a rubber cable type H07RN (WDE0282), whereby additional measures must be taken to protect against mechanical damage. To determine the required cross-section of the supply cable and the external fuse, use the data from the following table:

Consumption current (A)	Required wire cross-section	Required external fuse
up to 10	2.5 mm ²	12 A (slow)
from 10 to 14	4.0 mm ²	16 A (slow)
from 14 to 18	6.0 mm ²	20 A (slow)
from 18 to 22	6.0 mm ²	25 A (slow)
from 22 to 28	10.0 mm ²	32 A (slow)
from 28 to 36	10.0 mm ²	40 A (slow)
from 36 to 46	16.0 mm ²	50 A (slow)

7.7.2 Check Direction of Rotation

After connection via terminal box or CEE coupling, the correct direction of rotation must be checked

→ The main saw blade must rotate clockwise ↻ (see also marking on the saw blade guard).

	<p>If the saw blade direction of rotation is incorrect, the phases L1 and L2 must be interchanged.</p>
--	---

	<p>Important: Check the correct rotation direction of the saw blade during initial commissioning and after any change of the connections!</p>
--	--

8 Components and Controls

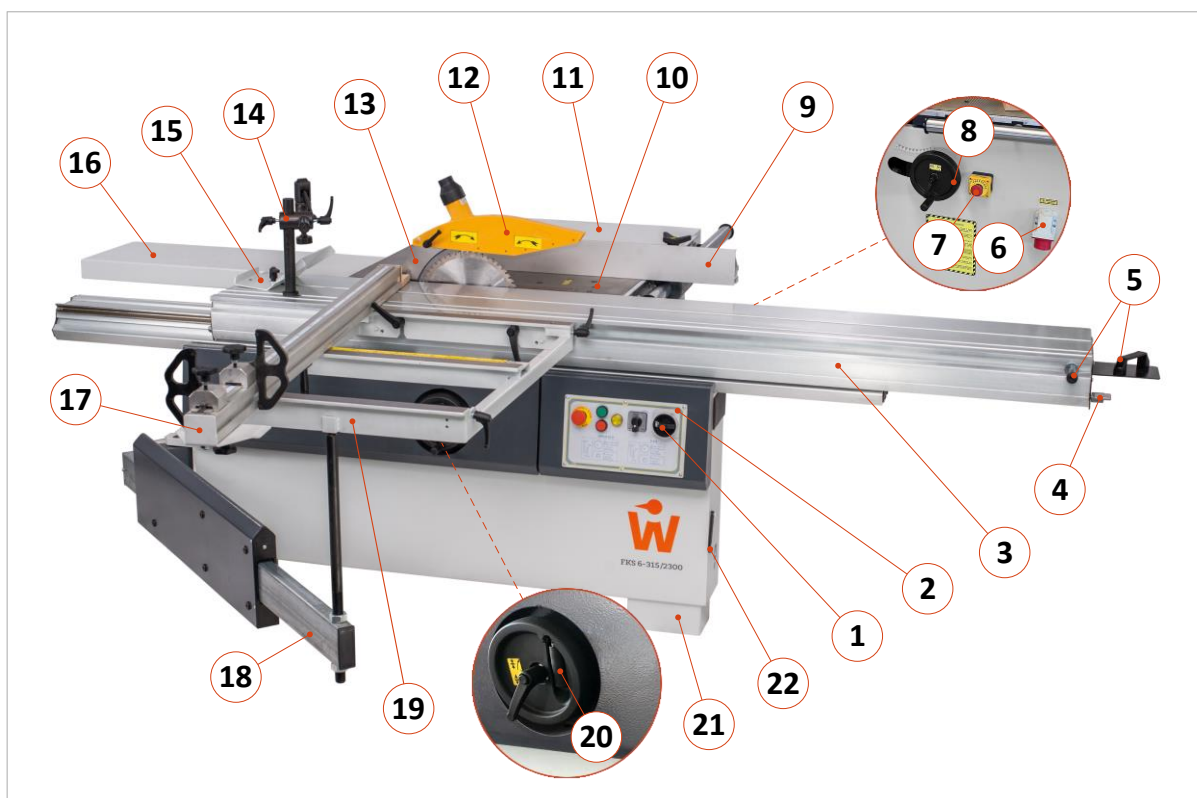

Figure 16: Components and controls

No.	Description	No.	Description
1	Main switch (lockable)	12	Saw blade guard with suction nozzle
2	Control panel with START / STOP / E-STOP	13	Riving knife
3	Sliding table	14	Eccentric clamping device
4	Locking lever for sliding table	15	Clamping shoe / anti-kickback device
5	Sliding handles for sliding table	16	Table extension
6	CCE connector (or terminal box)	17	Cross-cut fence with mitre function
7	Lateral E-STOP button	18	Extension arm with supporting rod for (19)
8	Handwheel for saw blade inclination	19	Cross-cut carriage
9	Rip fence	20	Hand wheel for saw blade height
10	Table top (planed)	21	Machine foot
11	Extension table	22	Locking lever for extension arm (18)

9 Saw Blade Positioning



Always set the height and tilt of the circular saw blade when the machine is switched off.

Note: You will find circular saw blades as accessories in chapter ⇒ 16.

9.1 Height Setting of the Saw Blade

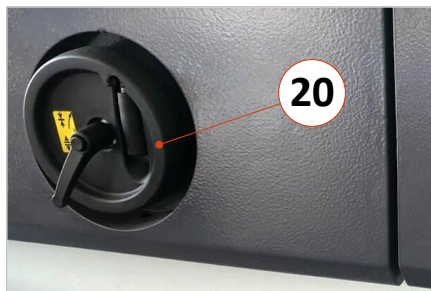

Figure 17: Height setting

The saw blade height is set with the handwheel (20) on the front of the machine.

- Loosen the clamping lever in the centre of the wheel, fold the crank handle outwards and set the desired height.
- A separate measuring device is required to determine the exact saw blade height.
- After setting, fold the crank handle back inwards and tighten the clamping lever again.



The saw unit can be completely lowered under the table top. To do this, the saw blade guard must first be removed (for procedure, see section ⇒ 10.1.4)

9.2 Tilt Setting of the Saw Blade



Figure 18: Tilt setting

The saw blade tilt is set with the hand wheel (8) on the right side of the machine. The adjustment range is 0° to 45°.

- Loosen the clamping lever in the centre of the wheel and set the inclination by cranking.
- The angle of inclination can be read off the angle scale.
- After setting, tighten the clamping lever again.

10 Mounting and Usage

10.1 Mounting and Adjusting the Saw Blade

	Before installing or replacing a saw blade, switch off the machine and secure it against being switched on again unexpectedly! Lock the main switch with a padlock!
	Never mount circular saw blades with an inner diameter > 30 H7 and do not use reduction or adapter rings to adapt larger bores to the shaft.
	Work on the saw blades must always be carried out with extreme care. There is an increased risk of injury due to the very sharp cutting edges! Protective gloves are mandatory during fitting or when changing the saw blade!

10.1.1 Preparation: Making the circular saw shaft accessible

Clean the table top and sliding table and remove all objects and tools lying on them.



Figure 19: Making the chip flap accessible

Standard saw blades with a bore diameter of 30 H7 mm and an outer diameter of 250 to 315 mm can be mounted on the circular saw shaft of the machine.

To be able to install a circular saw blade, access to the chip flap (S) must first be made. To do this, the sliding table (F) must be moved to the extended, left-hand end stop position. The procedure for this is described below.



Figure 20: Stop position



Figure 21: Press the safety catch



Figure 22: Extended range

1. Move the sliding table to the left until it reaches the stop (A) at the approx. saw blade centre.
2. At this point, press down the safety catch (K) to extend the movement range.
3. Push the sliding table completely to the left end position and **lock it**.

In the next step, open the chip flap so that the circular saw shaft becomes accessible:



Figure 23: Locking on right side

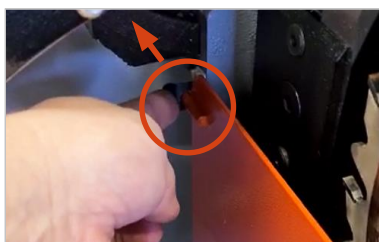

Figure 24: Locking on left side



Figure 25: Safety switch

1. Open the right-hand lock of the chip flap by pressing in the direction of the arrow.
2. Open the left lock by pressing in the direction of the arrow and fold down the chip flap.
3. The safety switch prevents the machine from being switched on when the flap is open.

10.1.2 Replacing / Mounting a Saw Blade



The saw blade must not be tilted when the chip flap is open!



Figure 26: Height setting wheel



Figure 27: Tilt setting wheel

- Set the saw blade with the front hand-wheel (20) to the uppermost position (⇒ Figure 26).
- Set the tilt of the saw unit with the side handwheel (8) to 0° respectively exactly right-angled to the machine table top (⇒ Figure 27).

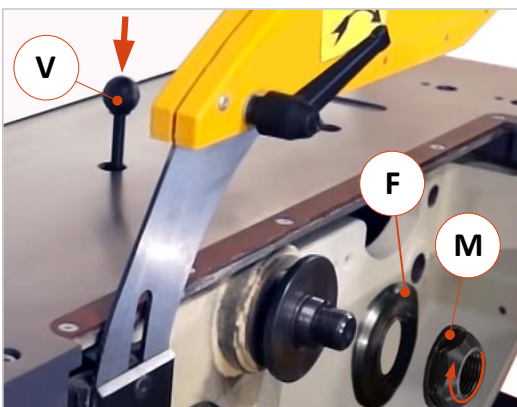

Figure 28: Saw shaft with flange and clamping nut

- Insert the shaft lock (V) into the opening behind the circular saw shaft (⇒ Figure 28) and turn the saw shaft manually until the shaft lock (V) engages.
- Use an open-end spanner SW 36 mm to remove the clamping nut (M) by turning it clockwise ↻ (left-hand thread!) and put it aside.
- Carefully remove the outer pressure flange (F) and put it aside as well.
- Clean the contact surfaces of the clamping nut (M), the pressure flange (F) and the circular saw shaft and check all parts for damage, bending and sharp edges. All contact surfaces must be clean and in perfect condition.



Protective gloves are mandatory during fitting or when changing the saw blade!



Check the circular saw blade for cracks, damage, missing or defective teeth etc. before fitting. Carry out this check at regular intervals thereafter.



Increased risk of kickback and injury when using incorrectly sharpened, defective or damaged circular saw blades!



Make sure that the speed indicated on the circular saw blade corresponds to the machine. The maximum permissible speed of the circular saw blade must not be exceeded!

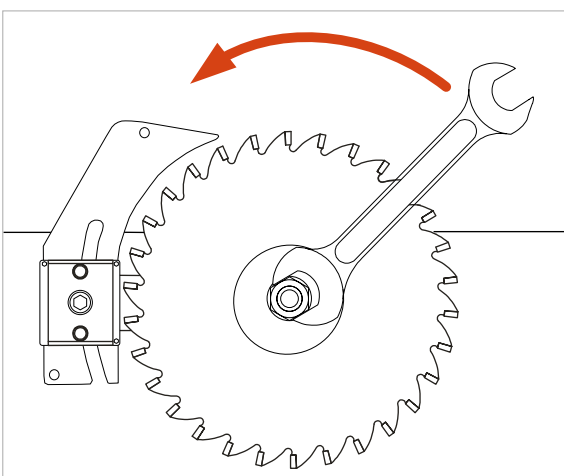

Figure 29: Fitting the circular saw blade

- Also clean the contact surfaces of the saw blade before mounting it.
- First place the new saw blade and then the pressure flange (F) onto the saw shaft.
Important: Note the direction of rotation of the saw blade (clockwise) → The teeth must point to the right when viewed from the front of the machine (see ⇒ Figure 29).
- Then screw on the clamping nut (M) by turning it anticlockwise (see arrow direction in ⇒ Figure 29) and tighten the circular saw blade well using the SW 36 mm spanner.



Important!

Pull the shaft lock (V) out of the table opening!

- Then adjust the riving knife according to the saw blade diameter (see section ⇒ 10.1.3).

10.1.3 Adjusting the Riving Knife

The correct riving knife setting is of great importance for safe working on the sliding table saw. An incorrect setting can cause dangerous workpiece kickbacks.

	<p>There is an increased risk of injury if the riving knife is missing or incorrectly adjusted! Please also note the hazard warnings in the section ⇒ 5.13.2.</p>
--	--

	<p>The thickness of the riving knife included in the delivery is 2.8 mm. <u>Important:</u> The riving knife must not be thicker than the kerf width and not thinner than the saw blade body.</p>
--	---

Important: Before adjusting the riving knife, remove the saw blade guard attached to it by unscrewing the clamping lever (K) shown in ⇒ Figure 31, with which the guard is mounted on the riving knife.

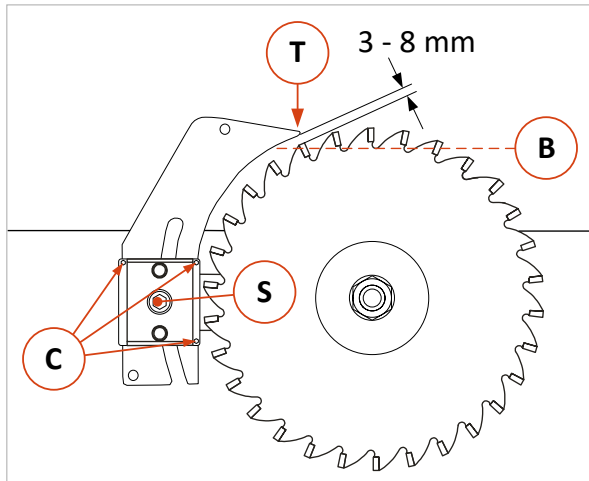

- The distance between the riving knife and the saw blade must be min. 3 mm and max. 8 mm.
- At the same time, the upper point (T) of the riving knife must not be below the base (B) of the top tooth of the circular saw blade.
- After loosening the screw (S) with an Allen key SW 6, the riving knife can be adjusted horizontally and vertically.
- Use the three small adjusting screws (C) to align the riving knife with the circular saw blade.

Figure 30: Adjusting the riving knife

After adjustment, retighten screws (S) and (C) and refit the saw blade guard to the riving knife (⇒ 10.1.4).

10.1.4 Fitting and Adjusting the Saw Blade Guard

The saw blade guard is mounted on the riving knife and adjusts automatically with the saw blade height.

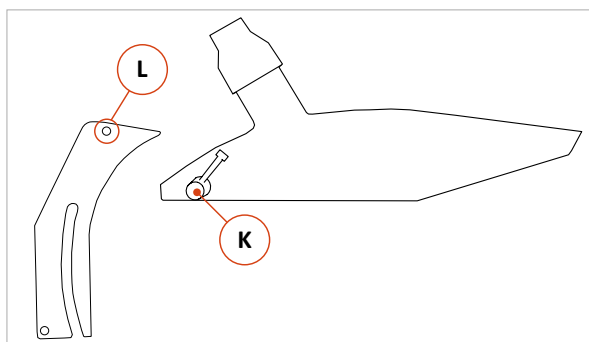

Figure 31: Fitting the saw blade guard

The saw blade guard is fixed with the clamping lever (K) in the upper hole (L) of the riving knife.

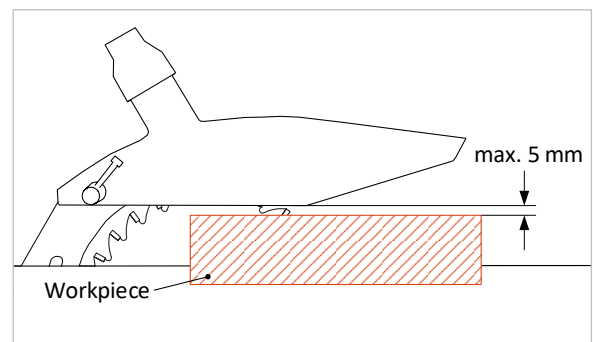

Figure 32: Adjusting the saw blade guard

The blade guard must be adjusted so that it is positioned a maximum of 5 mm above the workpiece.

10.1.5 Optional Overhead Saw Blade Guard

Optionally, the machine can be retrofitted with a pivoting overhead saw blade guard that includes a mounting rail and is wide enough to accommodate tilting circular saw blades.

For further details and article number see chapter ⇒ 16.

10.1.6 Scoring Unit (Option)

When equipped with this option, the machine has a mechanically adjustable scoring unit. The mounted scoring saw blade scores the piece of material a few millimetres deep before it reaches the actual circular saw blade. This is particularly helpful when processing veneered or hard-coated boards. Tears in the workpiece and deviations are effectively prevented, as the cutting forces of the main saw blade are no longer directed against the sensitive cutting edges after pre-scoring.

10.1.7 Replacing / Mounting a Scoring Saw Blade

One-piece, two-piece or cone-shaped scoring saw blades can be used. We generally recommend the use of two-piece scoring saw blades, which are brought to the required blade thickness by placing spacers between them. The kerf of the scoring saw blade should be approx. 0.1 mm wider than that of the main saw blade, i.e. 0.05 mm to each side.

Caution: Only scoring saw blades with a diameter of 120 mm may be used.

	Before installing or replacing a saw blade, switch off the machine and secure it against being switched on again unexpectedly! Lock the main switch with a padlock!
	Never mount circular saw blades with an inner diameter > 20 mm and do not use reduction or adapter rings to adapt larger bores to the shaft.
	Work on the saw blades must always be carried out with extreme care. There is an increased risk of injury due to the very sharp cutting edges! Protective gloves are mandatory during fitting or when changing the saw blade!

Make the scoring saw shaft accessible by opening the chip flap (follow the instructions in section ⇒ 10.1.1).

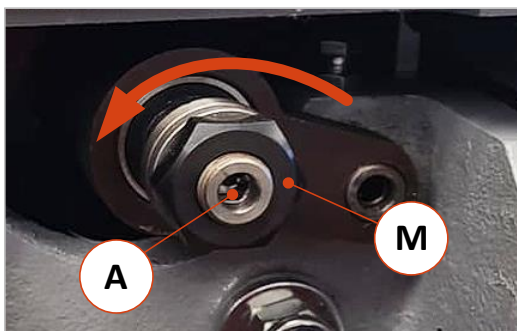

Figure 33: Loosen the scoring saw shaft clamping nut

- Fix the scoring saw shaft (A) with an SW 8 pin spanner and at the same time loosen the clamping nut (M) with an SW 36 open-end spanner by turning it in the direction of the arrow, see ⇒ Figure 33 (right-hand thread!)
- Remove the clamping nut and the pressure flange.
- Clean the contact surfaces of the clamping nut (M), the pressure flange (F) and the scoring saw shaft and check all parts for damage, bending and sharp edges. All contact surfaces must be clean and in perfect condition.

- Also clean the contact surfaces of the scoring saw blade (B) before mounting it. First fit the scoring saw blade and then the flange onto the shaft.

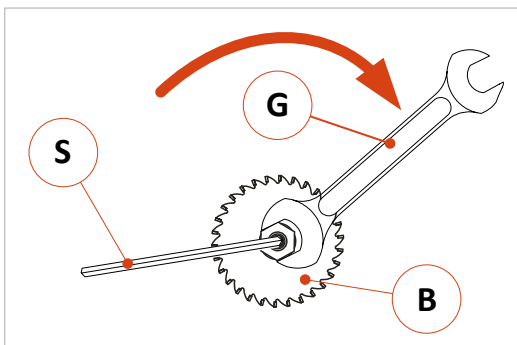

Figure 34: Inserting a scoring saw blade

- **Important:** Note the direction of rotation (counter-clockwise) of the scoring saw blade (B) → The teeth must point to the left when viewed from the front of the machine (see ⇒ Figure 34).
- Screw the clamping nut (M) onto the scoring saw shaft by turning it clockwise (see arrow direction in ⇒ Figure 34).
- Fix the scoring saw shaft (A) with an SW 8 pin spanner (S) and tighten the scoring saw blade well using the SW 36 open-end spanner (G), see ⇒ Figure 34.

	The direction of rotation of the scoring saw blade is opposite to the main saw blade.
--	--

10.1.8 Setting the Scoring Saw

The scoring saw blade must be correctly adjusted relative to the main saw blade. The vertical and horizontal adjustment is made via the two adjustment holes (**V**) and (**H**) in the table top and with the socket spanner (**S**) included in the delivery.

- Set the tilt of the main saw blade with the side handwheel (**8**) to 0°, respectively exactly right-angled to the machine table top (see also ⇒ Figure 27).
- The height of the scoring saw blade must be set so that the work-piece is pre-scored 1.5 - 2 mm deep.

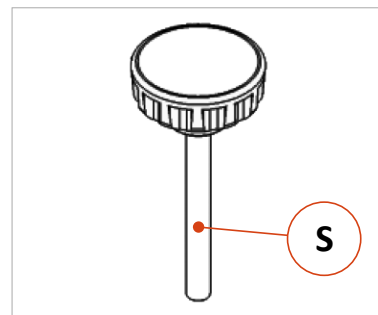

Figure 35: Socket spanner for setting



Figure 36: Set the scoring saw blade

- Vertical: Insert the socket spanner (**S**) into the table opening (**V**) to set the desired height.
 - The setting range for the height is 0 - 5 mm.
- Horizontal: To align the scoring saw blade horizontally to the main saw blade, insert the socket spanner (**S**) into the table opening (**H**).
 - One turn of the adjusting key offsets the scoring saw blade by 0.05 mm.
 - The setting range is ± 1 mm.

- After adjustment, make a test cut, check the correct setting of the scoring saw blade in relation to the main saw blade and correct the setting if necessary.

Important note: If the adjustment range of the scoring saw blade is not sufficient to position it in alignment with the main saw blade, follow the instructions in section ⇒ 13.1.

10.2 Mounting and Adjusting the Cross-cut Carriage



Due to the heavy weight of the cross-cut carriage, it should be mounted by 2 persons!



Increased risk of injury due to the cross-cut carriage falling down. Wear safety shoes!

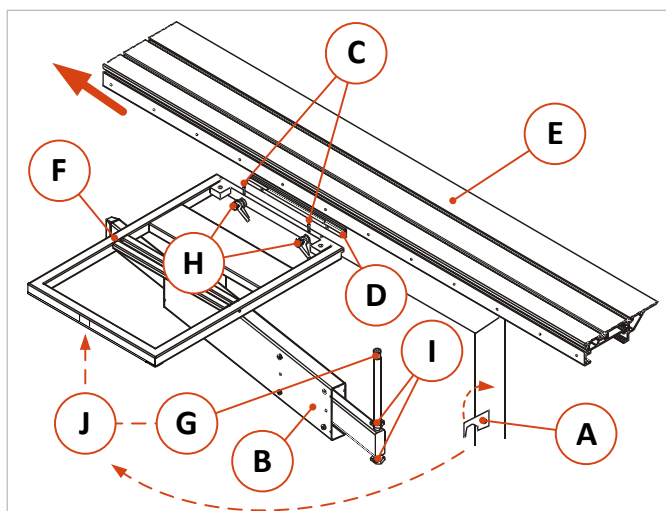

- Move the sliding table (E) all the way to the left (see direction of arrow).
- Fold the locking lever (A) upwards to be able to swivel the extension arm (B) so that the support rod (G) is under the receptacle (J) of the cross-cut carriage.
- Now attach the cross-cut carriage (F) to the guide rail (D) of the sliding table using the clamping levers (H). At the same time, place the cross-cut carriage with the receptacle (J) on the support rod (G) of the extension arm (B)
- Use a machine spirit level to align the cross-cut carriage exactly on all sides.

Figure 37: Mounting and adjusting the cross-cut carriage

- The two adjusting screws (C) can be used to align the cross-cut carriage exactly with the sliding table.
- The height of the rear cross-cut carriage end is adjusted on the support rod (G) via the two adjusting nuts (I) → Check the settings with a spirit level and readjust if necessary.
- After adjustment, both nuts (I) must be tightened again.



Danger of crushing when placing the cross-cut carriage on the support rod of the extension arm!

10.3 Attaching the Cross-cut Carriage

The ready-mounted cross-cut carriage, including guide rail (D), is simply placed on the support bolt (G) and inserted with the guide rail (D) on the left side of the sliding table. After moving to the desired position, it is fixed with the two clamping levers (H).

10.4 Moving the Cross-cut Carriage

Procedure for moving the cross-cut carriage (F):

- Open both clamping levers (H).
- Push the cross-cut carriage via the guide groove (F) to the desired position.
- Tighten both clamping levers (H) again.

10.5 Removing the Cross-cut Carriage

To remove the cross-cut carriage again, proceed as follows:

- Open both clamping levers (H).
- Push the cross-cut carriage (F) out onto the left end of the sliding table (E).
- Remove the cross-cut carriage (F) with 2 people and lift it off the support rod (G) at the same time.
- Then place the extension arm (B) against the machine body and secure it with the locking lever (A).

10.6 Mounting and Adjusting the Cross-cut Fence

The extendable cross-cut fence (C) can be mounted either on the left or right side of the cross-cut carriage (H). For this purpose, the cross-cut carriage has a fixing hole (E) on each side into which the cross-cut fence can be engaged with the fixing bolt (D) on the underside.

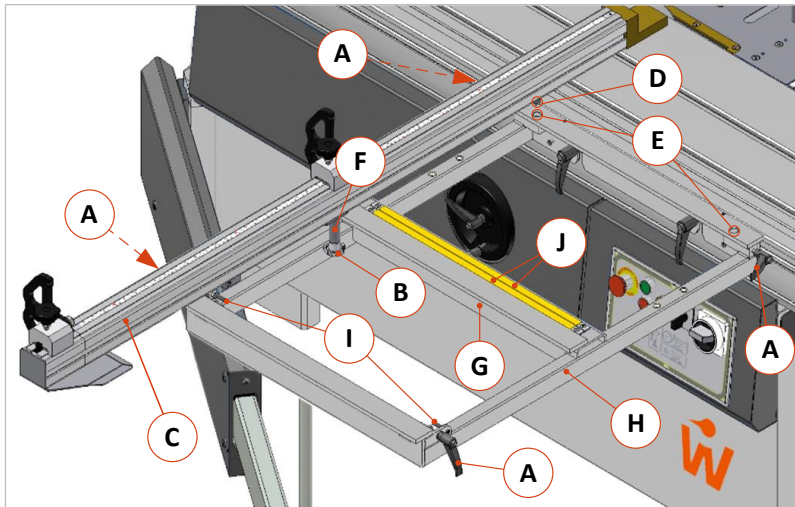

Set 90° angle:

For 90° cuts, the cross-cut fence is fixed with the two clamping levers (A) on the left or right side of the cross-cut carriage and the clamping wheel (B) on the corresponding side.

- Loosen both clamping levers (A) and clamping wheel (B).
- Insert the cross-cut fence (C) with the fixing bolt (D) on the underside into the left or right fixing hole of the cross-cut carriage (H).

Figure 38: Mounting and adjusting the telescopic cross-cut fence

- Align the guide bolt (F) on the batten (G) of the cross-cut carriage and fix it via the clamping wheel (B). Tighten the two clamping levers (A) on the cross-cut carriage (H) again.
- **Note:** The two bolts (I) serve as stoppers for the 90° setting on the left and right side. If necessary, these can be readjusted if the 90° angle to the circular saw blade is no longer correct.

Set mitre angle:

To machine angles and mitres, the cross-cut fence is only engaged on the front side (right or left) via the fixing bolt (D), while the rear part is adjusted to the desired angle via guide bolt (F) and angle scales (J) by swivelling in the corresponding direction.

- Loosen the clamping levers (A) on the cross-cut carriage and the clamping wheel (B) on the cross-cut fence.
- Use the back of the cross-cut fence and the guide bolt (F) to set the desired angle via angle scales (J). Then tighten the clamping wheel (B) and the clamping levers (A) again.

Set angular degrees via fixed grid:

The angular grid unit allows 5 common angular degrees to be mechanically stored. It can be used on the left or right side of the cross-cut carriage. The indexing templates (left and right) are screwed to the cross-slide frame as shown in ⇒ Figure 40. The scanning unit with the indexing bolt (R) is inserted into the lateral T-slot of the cross-cut fence and fixed with the clamping wheel (K). To deposit the 5 fixed degrees, loosen all fixing screws (S) of the snap-in points (C) as well as clamping lever on the side of the cross-cut carriage and proceed as follows:

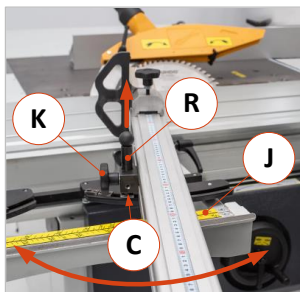

Figure 39: Angular grid

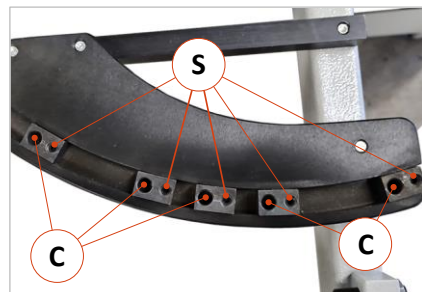

Figure 40: Indexing template (right)

- The adjustment must be made in sequence, starting with the outer or inner snap-in point (C).
- The outer position on the right (see ⇒ Figure 40) is recommended for the 90° position, for example.
- Engage the indexing bolt (R) in the first loose snap-in point and set the stop rail to the desired angle via the angle scale (J).

- Lift off the stop rail and fix the angle position with the fixing screw (S).
- Repeat this procedure with the remaining 4 snap-in points (C).
- To set one of the 5 stored angular positions when machining a workpiece, simply pull up the indexing bolt (R), approach the respective snap-in point (C) and let the bolt engage there.

10.6.1 Checking the tape measure for the cross-cut fence

After mounting the cross-cut fence and at regular intervals, the accuracy of the tape measure should be checked and readjusted if necessary. Inside the fixing bolt (D) there is the grub screw (E) with SW 4 spanner size. This screw fixes the tape measure from the underside. The grub screw (E) is accessible from the underside of the cross-cut carriage (X), as the fixing hole for (D) is through.

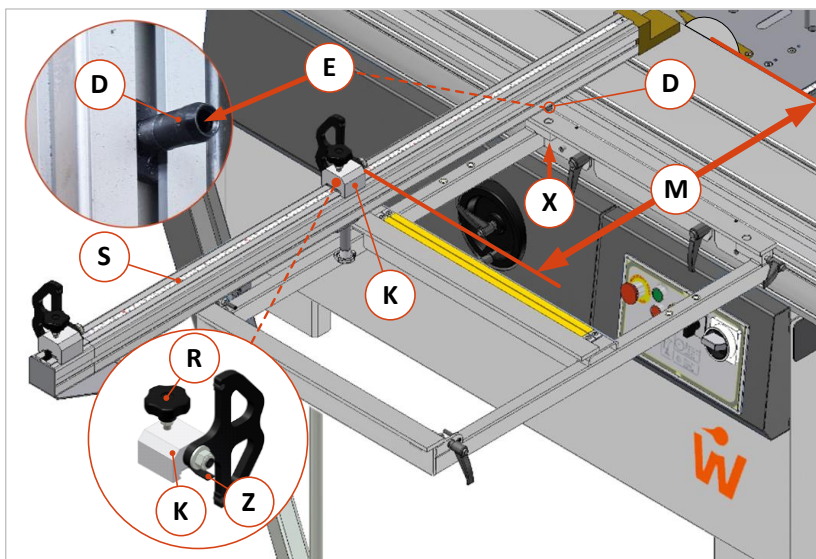

- Set the flip stop (K) via the reading pointer (Z) and tape measure (S) to any dimension to the circular saw blade and fix it with clamping wheel (R).
- Now use a suitable measuring device to re-measure the set distance between the pointer (Z) and the saw blade (M).
- If the measured distance (M) does not correspond to the tape measure (S), loosen the grub screw (E) from the underside (X) with an SW 4 Allen key.

Figure 41: Check and readjust the tape measure

- Then shift the tape measure (S) so that it matches the measured dimension (M).
- Tighten the grub screw (E) again, make a test cut and measure again.

10.7 Sliding Table

The lockable sliding table provides valuable support when feeding workpieces and ensures more flexibility and safety during machining.

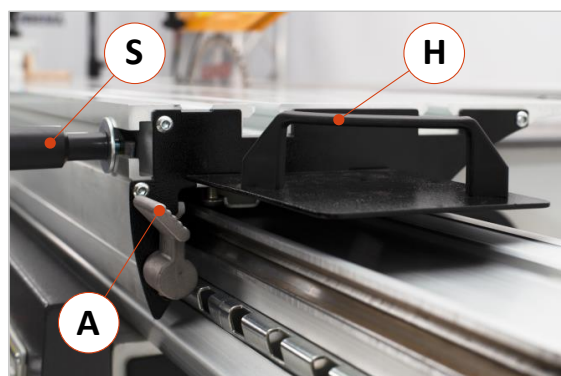

Figure 42: Operating the sliding table

Operating the sliding table:

- To lock the sliding table, press the locking lever (A) to the lower position.
- To move the sliding table, set the locking lever (A) to the upper position and move the table using the handle (H) or the push bar (S).

Remark 1: If the sliding table is not used to guide the workpiece, but only as a support, it must be locked in place.

Remark 2: If the sliding table is used for workpiece guidance, it is recommended to use it in combination with the cross-cut fence and to fix the workpiece on the infeed side with the eccentric clamping device on the top of the sliding table. For long workpieces and when trimming, it is recommended to use the clamping shoe (see section ⇒ 10.13).

Remark 3: For mounting or changing a saw blade, the sliding table must be positioned in its "extended" left end position. For details see section ⇒ 10.1.1.

	If the machine is not used for a longer period of time, the sliding table should be moved to a middle position to prevent the rollers from being pressed in.
--	---

	During a cutting operation the sliding table must not be locked.
--	---

10.8 Mounting the Rip Fence

To mount the rip fence on the machine, two persons are required.

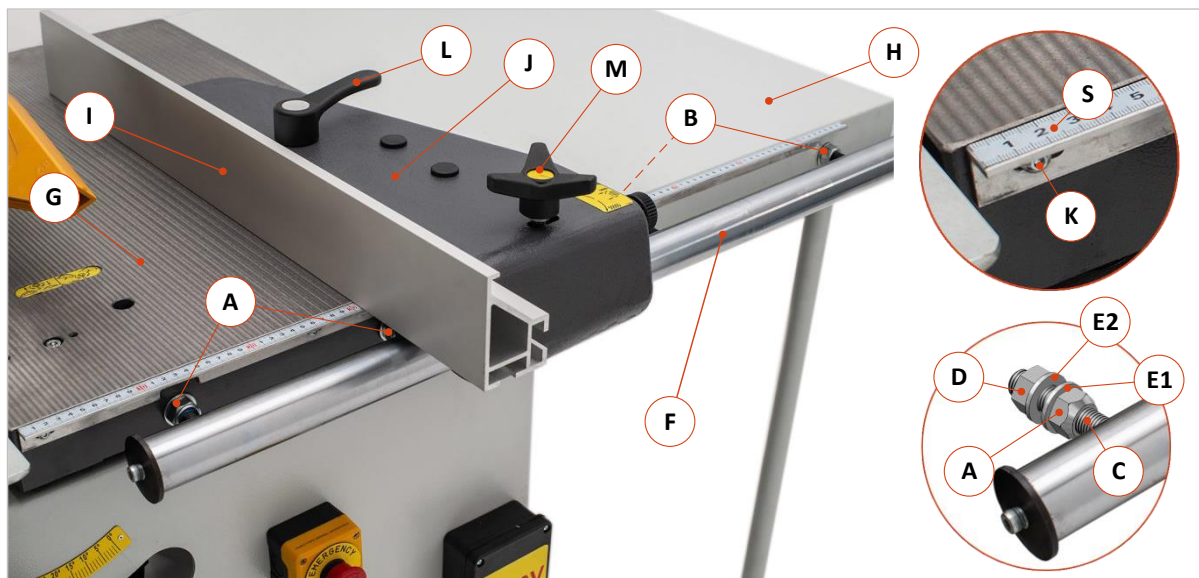

Figure 43: Mounting the rip fence

- Remove the nuts (D) with an SW 22 open-ended spanner as well as the corresponding washers (E2) from all threaded bolts (C) of the separately supplied guide round bar (F).
- The nuts (A) and one washer (E1) each must remain on the guide round bar.
Important: The nuts (A) **must not be adjusted or removed** under any circumstances and it must be ensured that all nuts (A) are each fitted with a washer (E1).
- Move the sliding table all the way to the left (as described in section ⇨ 10.7).
→ This makes the mounting holes of the machine table accessible for the threaded bolts (C) from the rear.
- Then mount the guide rod (F) into the mounting holes provided in the machine table (G) and the extension table (H). First insert the threaded bolts (C) together with the nuts (A) + washer (E1) into the mounting holes. Then, from the opposite side, put on the washers (E2) previously removed and screw on the nuts (D) by hand (do not tighten yet).
- Now push the stop profile (I) onto the fence body (J) and fix it with the lever (L). Then place the fence body (J) including the stop profile (I) on the round guide rod (F) and fix the device with the clamping handle (M).
- Use a 90° stop angle to align the stop profile (I) right-angled to the machine table (G) by tilting the guide round bar (F) accordingly. Only tighten the nuts (D) that are behind the nuts (A). The distance of the stop profile (I) to the saw blade must be 0.1 - 0.2 mm higher towards the rear (in the direction of the rising teeth) than in the front saw blade area.



Danger of kickback due to ejecting workpieces! The distance of the stop profile in front of the saw blade must never be higher than at the rear in the area of the rising teeth.

- Now insert the threaded bolts (C) together with the previously loosened nuts (B) + washer (E1) into the mounting holes of the extension table (H) and tighten them from behind by means of nuts (D). At the same time, hold the guide round bar (F) in the correct position (e.g. with the help of a ruler). Align the guide bar on the extension table with the nuts (B) + (D) so that it is parallel to the machine.
- Remove the screws (K) from the machine body and mount the millimetre scale (S) and temporarily tighten the screws (K) only slightly with an SW 3 Allen key.
- Set the rip fence to any dimension using the millimetre scale (S) and cut a test piece.
→ Then measure the cut test piece and correct the millimetre scale (S) if necessary.
- Finally, fully tighten all nuts (K) to fix the scale in this position.

10.9 Operating the Rip Fence

10.9.1 Setting the Rip Fence

The rip fence is used to feed the workpiece from the back of the machine (to the right of the saw blade).



Important: For the operation of the rip fence, please also observe the hazard warnings and solutions in the sections ↗ 5.13.4, ↗ 5.13.5 and ↗ 5.13.6.

- The stop profile (I) serves to guide the workpiece along the circular saw blade.
- The rip fence is fixed resp. loosened on the guide rod (F) using the clamping handle (M).
- First tighten the clamping handle (M) and adjust the adjusting wheel (P) so that the bolt of the clamping handle (M) is approximately in the middle (Z) of the slotted hole.
- Then loosen the clamping handle (M) and push the rip fence roughly to the desired position.
- Tighten the clamping handle (M) again and make the fine adjustment using the adjusting wheel (P). Read off the cutting dimension from the millimetre scale (S).

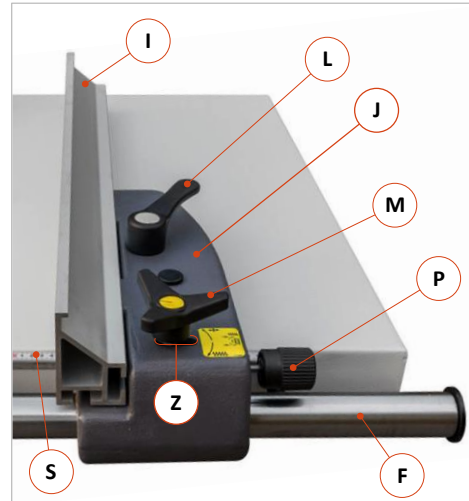

Figure 44: Operating the rip fence



Caution! There is a risk of crushing between the workpiece or the stop profile and the sliding table.



Increased danger of cutting the saw blade! Always switch off the machine when setting cutting widths < 120 mm and generally use a push stick to feed the workpiece. For cutting widths < 30 mm use an adequate push block for feeding. Due to the risk of collision with the circular saw blade, do not set cutting widths < 15 mm.



Danger of collision with tilted saw blade! Turn the stop profile to its flat position (⇒ 10.9.2).

10.9.2 Change stop profile from high to flat

For machining flat workpieces or when the saw blade is tilted, the fence profile must be turned by 90°.

- Release the clamping lever (L) and pull the stop profile (I) out of the fence body (J).
- Turn the stop profile (I) by 90° to the flat side, reinsert it and tighten the clamping lever (H).



Attention! Danger of crushing between stop profile (I) and fence body (J).

10.9.3 Folding the Rip Fence away

When not in use, the rip fence can be folded out of the table area.

- To do this, loosen the clamping handle (M) and push the fence all the way back.
- In this position, the fence can be folded away by 180°.
- To fold the fence all the way down (270°), move it so that it cannot rest on the rear threaded bolt (C) shown in ⇒ Figure 43.



Caution! Increased risk of crushing and injury when folding back into the working position. Hold the fence firmly with both hands so that it cannot fall down.

10.10 Mounting the Table Extension

The lateral table extension can be mounted flush to the machine table in just a few steps.

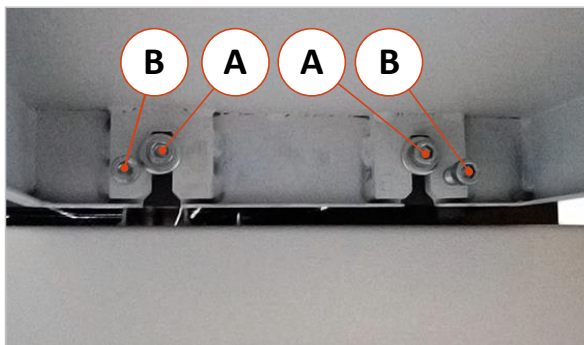

Figure 45: Mounting the table extension

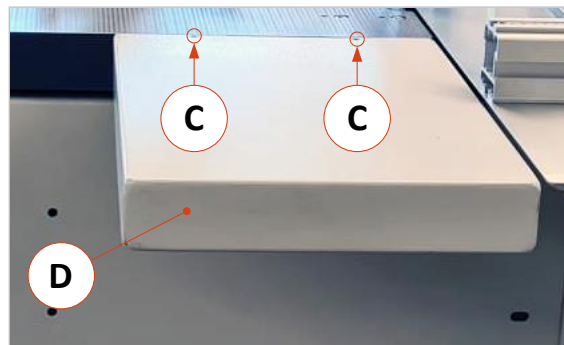

Figure 46: Height adjustment screws



Use a machine spirit level to align the table extension exactly!

- Loosen the two screws (A) located in the machine body with an SW 8 Allen key and unscrew them so far that you can hook the two table extension holders (D) between the washers and the machine body (see ⇒ Figure 45).
- Align the table edge of the extension table flush with the machine table edge using the screws (A).
- Align the inclination to the machine table edge by means of screws (B).
- The height of the table extension edge can be adapted to the machine table via the two adjusting screws (C) on the top using an SW 3 Allen key.
- After the adjustment is complete, tighten the screws (A) well.

10.11 Mounting the Extension Table

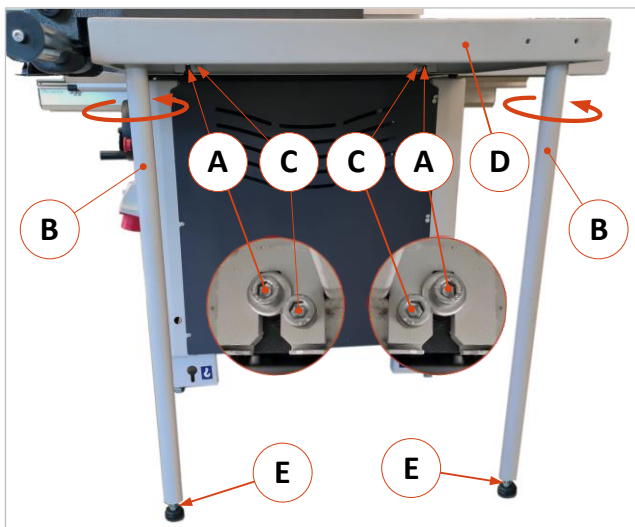

Figure 47: Mounting the extension table

- Mount the two supplied table legs (B) in the threaded sockets on the underside of the tabletop as shown in the figure. Then tighten them both well.
- Loosen the two screws (A) located in the machine body with an SW 8 Allen key and unscrew them until you can hook the other side of the tabletop (D) between the washers and the machine body (see enlarged views in the Figure).
- Align the table side flush with the machine table edge using screws (A) and the inclination to the machine table edge using screws (C).



Use a machine spirit level to align the table exactly on all sides!

- For this purpose there are (as also shown in ⇒ Figure 46) two small holes with height adjustment screws in the upper side of the table top. For adjustment, an SW 3 Allen key is required.
- After the adjustment is complete, tighten the screws (A) well.
- The height of the side facing away from the machine is adjusted via the two adjustable feet (E). This requires an SW 19 open-ended spanner.

10.12 Eccentric Clamping Device

When machining workpieces (e.g. large panels) on the sliding table, the eccentric clamping device can be used as fixation and as an anti-kickback device.

It can be used in combination with the cross-cut fence (see ⇒ 10.6) as well as the clamping shoe (see ⇒ 10.13), e. g. when trimming.

- The device is inserted into one of the two grooves of the format sliding table and fixed in the desired position by turning the vertical axis.
- The ball handle lever is used to clamp the workpiece on the table.
- The other two clamping levers are used for vertical and horizontal adjustment.



Figure 48: Eccentric clamping device



Optimum clamping is achieved when the clamping pad is positioned approx. 2 mm above the workpiece surface before clamping with the ball handle lever.

10.13 Clamping Shoe



Figure 49: Clamping shoe

The clamping shoe together with the eccentric clamping device (see section ⇒ 10.12) serves as a hold-down device as well as an effective anti-kickback device when processing long workpieces on the sliding table (e.g. when trimming or ripping).

- The left side of the clamping shoe, shown in ⇒ Figure 49 serves as a kickback protection for placing workpieces.
- The angled side (right) is used as a downholder.

For trimming or ripping, fix the workpiece on the infeed side (right) with the eccentric clamping device. Then insert the clamping shoe on the removal side (left) into a groove of the sliding table, push it with the angled side over the workpiece and fix it with the clamping lever → The workpiece is thus secured on both sides.

10.14 Push Stick



Figure 50: Push stick

The push stick included in the scope of delivery is of elementary importance for safety on the sliding table saw when narrow workpieces are to be machined on the rip fence.

- For cutting widths < 120 mm a push stick is mandatory.
- For cutting widths < 30 mm use an adequate push block for feeding.

11 Commissioning

	<p>Before commissioning, the accident prevention regulations and chapter ⇒ 5 "Safety" must be observed! Before switching on, check that</p> <ul style="list-style-type: none"> • the saw blade guard and other guards are fitted as prescribed, • there are no loose parts on the table top and all tools have been removed, • the riving knife is correctly adjusted and the chip flap is closed, • the sliding table is in working position, • the drive belt is tensioned, • the extraction system is connected and in working order, • no persons are present in a danger zone of the machine.
--	--

11.1 Operating Switches

The following controls are available on the control panel of the FKS 6-315/2300 sliding table saw:



Pos.	Description
1	Main switch
G	Green button = start circular saw
S	Signal lamp (ready for operation)
R	Red button = stop circular saw
N	Front emergency stop button
V	Scoring saw start/stop (option)
7	Side emergency stop push button

Figure 51: Operating switches of the machine

11.1 Switching ON and OFF

The main switch (1) on the control panel is used to switch the machine's power supply on and off:

- **Switching ON:** Turn the main switch to position "I" → The signal lamp (S) lights up statically.
- **Switching OFF:** Turn the main switch to position "O".

11.2 Switch ON the Sawing Unit

	<p>Before switching on, make sure that the shaft lock (V) has been removed (⇒ Figure 28).</p>
--	--

- **Optionally:** When using the scoring saw, turn the rotary switch (V) to position "1".
- To start the main circular saw, press the green push button (G).
 - **Important:** Do not start working until full speed has been reached.
 - The cutting operation can now be started.

11.3 Switch OFF the Sawing Unit

- To switch off, press the red push-button (R) → The circular saw is braked (braking time < 10 s).
- Turn main switch (1) to position "O".

	<ul style="list-style-type: none"> • The braking time of the motor to a standstill must not exceed 10 seconds. • Do not switch off with the main switch (1) or the rotary switch (V). No braking function!
--	--

11.4 Emergency Stop Function

In case of danger or malfunctions in the work process, the machine can be stopped quickly (braking time < 10 s) and reliably via the front emergency stop button (N) or the side emergency stop button (7). Before restarting the machine, the corresponding emergency stop button must be unlocked again.

12 Working with the Sliding Table Saw

12.1 General Instructions

- Always adjust the circular saw blade guard according to ⇒ Figure 32. The toothed rim of the circular saw blade must be reliably covered by the saw blade guard.
- Feed the workpiece to the circular saw blade consistently in one pass (without interruption and without retracting it) until the end of the cutting process.
- Only set the height and tilt of the circular saw blade when the machine is switched off.
- For cutting widths < 120 mm generally use a push stick for feeding on the rip fence. For cutting widths < 30 mm use an adequate push block for feeding on the rip fence.
- Make sure that the machine runs without vibrations.
- Always work only with functional and perfectly sharpened circular saw blades.
- Select the number of teeth of the circular saw blade so that at least 2-3 teeth enter the workpiece at the same time. A lower number of teeth results in a poor machining surface, bears the risk of material kickbacks and leads to vibrations as well as an increased noise pollution.
- Cracked, chipped and deformed circular saw blades must not be used and must be replaced immediately with new ones. Circular saw blades can be found as accessories in the section ⇒ 15.2.
- Make sure that the saw blade used is designed for the machine speed of 4000 rpm and do not start feeding the workpiece until the speed has been fully reached .
- When repairing and maintaining circular saw blades with brazed-on blades (e.g. brazing on new cutting plates), the design of the circular saw blades (tooth shape, tooth width) must not be changed.
Note: We generally recommend the use of new circular saw blades.
- Pay attention to the correct hand position when feeding the workpiece manually. Place your hands flat on the workpiece with closed fingers and keep a sufficient safety distance (min. 120 mm) to the saw blade. If a sufficient safety distance cannot be established, appropriate pushing aids must be used.
- Adjustment, maintenance and repair work may only be carried out when the machine is switched off and the main switch is locked.

12.2 Permissible Working Techniques

Only the following working techniques are permitted on this sliding table saw:

- ✓ Longitudinal cuts up to max. 45° at the rip fence (only with locked sliding table)
- ✓ Longitudinal cuts up to max. 45° at the cross-cut fence with the format sliding table
- ✓ Cutting workpieces to length on the cross-cut fence or rip fence
- ✓ Trimming and ripping (only using the clamping shoe)
- ✓ Dividing large panels
- ✓ Rebating (concealed cutting) on the rip fence (only without scoring saw!)

12.3 Improper Working Techniques

The following working techniques must not be carried out on this machine under any circumstances:

- ✗ Operations without the use of cross-cut fence, rip fence and cross and/or sliding table.
- ✗ Grooving (concealed cutting) with grooving cutter
→ There are no approved grooving cutters for this machine!
- ✗ Removing the riving knife or the saw blade guard (only in exceptional cases when insert cutting).
- ✗ Cutting oversized workpieces that exceed the machine's capacity.
- ✗ Cutting to length and ripping logs with the standard fences and pushing aids.

12.4 Permitted Operations

12.4.1 Longitudinal cutting of narrow Workpieces < 120 mm

Procedure	Saw blade
<ul style="list-style-type: none"> • Set the stop profile of the rip fence to the desired cutting dimension. • Adjust the saw blade height and ensure that the saw blade guard is positioned max. 5 mm above the workpiece surface. • Place the workpiece on the sliding table, place it against the stop profile of the rip fence and feed it consistently towards the saw blade with the sliding table. • In the danger zone of 120 mm around the saw blade, use the push stick and push the cut piece through behind the riving knife. • For short workpieces, work with the push stick from the beginning. 	Longitudinal cut saw blade

12.4.2 Cutting Battens

Procedure	Saw blade
<ul style="list-style-type: none"> • Turn the stop profile of the rip fence to its "flat" position (⇒ 10.9.2). • Set the stop profile of the rip fence to the desired batten width and pull it back far enough to prevent the workpiece from jamming. • Adjust the saw blade height and make sure that the saw blade guard is positioned max. 5 mm above the workpiece surface. • Place the workpiece on the sliding table and press it against the stop profile of the rip fence with your left hand. • Use the sliding table to feed the workpiece consistently towards the saw blade. In the danger zone of the saw blade, use a pushing aid (e.g. push block, push handle, etc.). • Push the cut batten forward until it is behind the riving knife. 	Fine cut saw blade

12.4.3 Edge Cutting (Trimming)

Procedure	Saw blade
<ul style="list-style-type: none"> • Mount the clamping shoe on the removal side of the sliding table. • Place the workpiece with the hollow side facing downwards and press it under the under the fixed clamping shoe. • Attach the eccentric clamping device to the other side of the workpiece and clamp the workpiece on the sliding table. • Apply the feed pressure with the clenched right hand against the edge of the workpiece. • Feed the workpiece consistently to the saw blade with the sliding table and make the cut in one pass. • Keep your hands out of the danger zone of the saw blade. 	Longitudinal cut saw blade

12.4.4 Cross-cutting of wide Workpieces

Procedure	Saw blade
<ul style="list-style-type: none"> • Place the workpiece against the cross-cut fence and press it firmly against the stop profile with your left hand during the feed. • If a flip stop is used for dimension setting, it must be folded up and the workpiece moved away from the saw blade or first removed behind the rising sprocket before it is retracted after the cut. 	Cross cutting saw blade

12.4.5 Cross-cutting of narrow or short Workpieces

Procedure	Saw blade
<ul style="list-style-type: none"> • Mount a deflector wedge on the table (as shown in ⇒ Figure 5) and pull the rip fence back far enough to allow safe retraction of the workpiece. • Set the desired cutting dimension on the rip fence. • Place the workpiece against the cross-cut fence and feed it. • Do not remove cut pieces and waste pieces by hand. 	<p>Fine cut circular saw blade</p>

12.4.6 Cutting Workpieces to Length

Procedure	Saw blade
<ul style="list-style-type: none"> • Place the workpiece against the cross-cut fence. • Set the desired cutting dimension on the rip fence. • Then loosen the clamping of the rip fence and pull the stop profile (towards the operator) until it is in front of the saw blade to prevent the workpiece from jamming. • Feed the workpiece to the saw blade with the sliding table. 	<p>Depending on workpiece dimensions, material and desired surface</p>

12.4.7 Dividing large Panels

Procedure	Saw blade
<ul style="list-style-type: none"> • Dimension setting is possible at the rip fence as well as at the cross-cut fence. This depends on the panel size and cutting width of the machine. • To divide a panel into several pieces of the same size, it is recommended to first cut narrow strips at the rip fence and then cut them to the desired length at the cross-cut fence. • If the pieces to be produced are larger than the cutting width of the machine, the cutting dimension is set via the cross-cut fence and the panel is placed on the cross-cut carriage. 	<p>Longitudinal cut saw blade or special Panel sizing saw blade</p>



Increased risk of injury due to heavy panels tipping and/or falling down!

For cuts at the rip fence, the extension table is required as a support.

For cuts at the cross-cut fence, the cross-cut carriage must generally be used as a support.

12.5 Conditionally permitted Operations

The operations described below are only conditionally permissible on this machine.

	Increased risk of injury due to workpiece kickback during subsequent operations!
---	---

12.5.1 Concealed Cutting (Rebating)

Remark 1: This operation is only allowed without scoring saw (option).

Remark 2: This operation must only be carried out with the optional overhead saw blade guard (see section ⇒ 16.2 - Art. No. FKS6-315/2300-003).

Procedure	Saw blade
<ul style="list-style-type: none"> Lower the saw blade including the riving knife to the desired cutting depth and lower the overhead saw blade guard to workpiece height. The saw blade must not project beyond the upper edge of the rip fence stop profile! Otherwise a correspondingly high auxiliary fence must be used to ensure safe guidance. Set the dimension on the rip fence with the saw blade stationary. Danger of kickback! The cut-out piece must fall on the side of the sliding table resp. on the front of the machine. If the cut-out piece is on the rip fence side, the workpiece must be pushed forward with a push stick. Feed small and narrow workpieces with a push stick, push block or similar feeding aids and keep your hands out of the dangerous area (120 mm around the saw blade). 	<p>Fine cut circular saw blade</p>
	<p style="text-align: center;">Requirement</p>
	 <p style="text-align: center;"><i>Figure 52: Overhead guard</i></p>

12.5.2 Insert Cutting

Note: It is generally recommended to carry out the operation “Insert cutting” using a manual circular saw with guide rail or on a vertical panel saw. If this operation is nevertheless to be carried out on the sliding table saw, observe the following procedure:

Procedure
<ul style="list-style-type: none"> Remove the riving knife and saw blade guard. Tighten the riving knife holder firmly. Use the front of the clamping shoe as an anti-kickback device. Lock the sliding table in position and use it in conjunction with the longitudinal stop as an anti-kickback device. the cross-cut fence as an anti-kickback device. Determine the insertion point and the positions of the anti-kickback devices for the intended saw blade position with the saw blade stationary. Adjust the rip fence (if necessary with an additional auxiliary fence) as a lateral guide to the desired distance between the edge of the workpiece and the saw blade. Lower the circular saw blade completely and place the workpiece against the right anti-kickback device. Set the saw blade to the intended height and push the workpiece forward to the left anti-kickback device. Only guide the workpiece by the outer edges and keep your hands out of the danger zone of the saw blade. After cutting, lower the saw blade completely, switch off the machine and remove the workpiece. After insert cutting, immediately replace the riving knife and the saw blade guard. immediately.

13 Troubleshooting

Proceed systematically when searching for the cause of a malfunction. If you are unable to find the fault or to remedy the malfunction, contact our customer service department (phone number: 0049 7571 / 755 - 0).

Before you call us, please follow these steps:

- Make a note of the type, machine number and year of production (see nameplate).
- Keep this operating manual (and any circuit diagrams) to hand.
- Describe the fault to us in detail so that a competent remedy can be found.

Fault	Possible Cause	Remedy
Machine does not start	No voltage / wrong connection	→ Check power supply, connections and phases (electrician!)
	External backup fuse defective	→ Check / renew fuse
	Overload protection tripped	→ Check F1.1/F1.2/F1.3, see ⇒ 15 "Circuit Diagram" (electrician!)
	Main switch defective	→ Replace main switch (electrician!)
	Motor defective	→ Check/replace (customer service)
	Motor overheated	→ Switch off the machine and let the motor cool down for a while. Only then switch it on again.
	Drive belt broken	→ Replace drive belt
	An emergency stop button is activated	→ Unlock the emergency stop button
Motor does not reach full speed	Motor defective	→ Check/replace (customer service)
	Voltage too low	→ Check voltage (electrician!)
Motor slows down during work	Workpiece is fed too quickly	→ Feed slowly with less pressure
	Insufficient V-belt tension	→ Tension drive belt (⇒ 14.7)
Machine vibrates or saw blade strikes	Saw blade unsuitable for the machine	→ Only use approved saw blades
	Saw blade unsharp/damaged/defective	→ Install new saw blade
	Saw blade insufficiently clamped	→ Clamp saw blade correctly
	Handwheel clamping height/tilt loose	→ Fix handwheels with clamping levers
	Machine stands unevenly	→ Level the machine (⇒ 7.3)
Saw blade does not start or stops on contact with workpiece	Insufficient V-belt tension	→ Tension drive belt (⇒ 14.7)
Saw blade rotates unevenly on contact with the workpiece	Insufficient V-belt tension	→ Tension drive belt (⇒ 14.7)
Braking time > 10 s	Error in the electronic control	→ Contact customer service
Workpiece kickbacks	Riving knife not correctly aligned	→ Align correctly to the saw blade
	Fences are not set correctly	→ Set fences correctly
	Saw blade damaged or defective	→ Install new saw blade
The full cutting length is no longer achieved.	With many short strokes the sliding table can be misaligned	→ Push the sliding table briskly beyond the resistance to the end stop, and then briskly to the other end stop

13.1 Faults with optional Scoring Saw

Fault	Possible Cause	Remedy
Workpiece tears out on the underside during cutting	Scoring saw blade misaligned	→ Align correctly to main saw blade
	Scoring saw blade height incorrectly adjusted	→ Adjust height correctly
	Scoring saw blade is worn out	→ Install new scoring saw blade
Workpiece tears out despite scoring saw	Not correct aligned to the main saw blade	→ Adjust scoring saw blade correctly
	Too narrow scoring saw blade	→ Use suitable scoring saw blade
Workpiece lifts up during scoring	Scoring saw blade is blunt	→ Replace scoring saw blade
	Cutting height selected too low	→ Set higher cutting height

Fault	Possible Cause
The adjustment range of the scoring unit is not sufficient to position it in alignment with the main saw blade.	There are one-piece, two-piece or tapered scoring saw blades. You may be using a scoring saw blade that is different from the one with which the machine was set at the factory.

Remedy
<p>After turning the adjusting wheel (1) in one direction, the end stop is already reached → <u>however, the adjustment range is not sufficient to adjust the scoring saw blade.</u></p> <p>In this case, proceed as follows:</p> <ul style="list-style-type: none"> • Turn the adjusting wheel (1) approx. 10 - 15 turns in the opposite direction. • Loosen the nut M8 (3) and the screw M8 x 25 (4). • With light tapping on the axis (2) in both directions, set the scoring wheel as close as possible to the cutting surface of the main circular saw blade. • Tighten the nut (3) and screw (4) again. • By turning the adjusting wheel (1) in one direction or the other, the scoring unit can be fine-adjusted to the main saw blade (adjustment travel = 0.05 mm per turn).

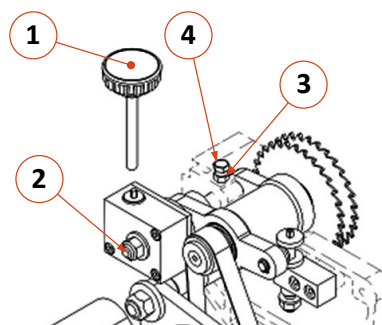

14 Maintenance and Inspection



Before carrying out any maintenance and inspection work, chapter ⇨ 5 "Safety" must be read carefully and observed!

Breakdowns caused by inadequate or improper maintenance can result in very high repair costs and long machine downtimes. Regular maintenance is therefore essential.



Switch off the machine during all maintenance and repair work and secure it against being switched on again unexpectedly! Lock the main switch with a padlock!

Due to the different operating conditions, it is not possible to determine in advance how often a wear check, inspection or maintenance is required. Appropriate inspection intervals should be determined considering your operating conditions.

- Clean the machine regularly (see section ⇨ 14.1) .
- Remove and replace damaged parts. Never work with damaged parts!
- Replace damaged guards, saw blades, clamping flanges, clamping nuts and riving knives immediately. Never work with damaged parts!
- Inspect electrical equipment/components weekly for externally visible damage and have any damage repaired by a qualified electrician if necessary.
- Check the extraction system for full function daily before starting work.
- The extraction system must be checked for obvious defects before initial operation, daily and monthly to ensure its effectiveness..
- The air velocity to the extraction unit must be checked before the initial start-up and after significant modifications.
- Do not use the machine until these conditions are met.
- Our specialists will be happy to provide you with further advice.

14.1 Cleaning

Regular and thorough cleaning guarantees a long service life of the machine and also contributes to safety.

- After each work shift, the machine and all its parts must be thoroughly cleaned by removing dust and chips from the surfaces of the table top and sliding table as well as from the machine interior.
- Clean all moving parts every week with turpentine or other suitable and safe solvents.
- Clean the guideways of the sliding table monthly. Take special care to thoroughly clean all guides as well as the ruler support for the cross-cut fence and the T-slots in the sliding table and clean them with a soft brush and turpentine or other suitable and safe solvents.
- To remove dust and chips, clean the machine's belts with a soft brush approximately every 500 hours of operation.



Avoid cleaning with compressed air, as the wood dust produced can penetrate the bearings and guides of the machine and is also distributed in the workshop!

14.2 Lubrication

The machine was subjected to a test run at the factory for a longer period of time and was already lubricated ready for operation. Relubrication before commissioning is therefore not necessary.

- Clean all sliding/rolling parts weekly and check for smooth running. If necessary, lubricate with a thin oil.
- Apply a few drops of oil weekly to the threads of clamping and adjusting levers.
- When lubricating parts in the interior, cover the belt and pulleys to avoid contamination by oil and grease.

Lubricate the machine only with special grease, e.g.

- **ARCANOL BN 102**
- **CALIPSOL H442B**
- **Shell Gadus S2 V100 3 (formerly SHELL Alvania 3)**

For oil lubrication we recommend:

- **Motor oil type 20 W 40**

Always use the same grease/oil.

14.3 Checking the Electronic Motor Brake

- The machine has an electronic brake for electrodynamic braking of the motor.
- If the machine is switched off with the red push button (**R**) shown in ⇒ Figure 51, the braking time until the sawing unit stops completely must not exceed 10 seconds.
- This braking time must be checked once a month. If it is more than 10 seconds, the motor brake must be checked by a qualified electrician.
- **Important:** The motor brake is designed for a maximum of 10 braking operations per hour.

14.4 Checking the Safety Devices

14.4.1 Checking the Emergency Stop Buttons

Check the function of the two emergency stop buttons weekly:

- To do this, press one of the two emergency stop buttons in succession while the machine is running
→ The machine switches off the drive immediately and the saw shaft stops within the braking time (< 10 s).
- To be able to restart the machine, the corresponding emergency stop button must be unlocked again (turn to the right or pull out).

14.4.2 Checking the internal Safety Switch

Carry out the following safety check weekly:

- Move the sliding table (as described in section ⇒ 10.1.1) to the left “extended” end stop position and open the chip flap so that the internal safety switch is activated.:
→ It must not be possible to start the motor.
Otherwise, the safety switch is defective and must be replaced.
In this case, please contact our customer service.

14.4.3 Checking the Safety Labels

- Check regularly that all safety labels on the machine are present and in good legible condition.
- The safety labels must be completely present and always clearly legible.
This applies especially to the safety instructions.

14.4.4 Checking the Saw Blade Guard

Check the condition of the saw blade guard daily before starting work:

- The saw blade guard must not be cracked, bent or otherwise damaged.
- The saw blade guard must be properly and securely fastened to the riving knife.
- Damaged and saw blade guard and those that can no longer be securely fastened to the riving knife must no longer be used and must be replaced immediately.

14.4.5 Checking the Riving Knife

Check the condition of the riving knife daily before starting work:

- The riving knife must not be cracked, bent or otherwise damaged.
- The riving knife must be securely and tightly fastened to its support.
- Check all screw connections and tighten them if necessary.
- The riving knife must be correctly adjusted to the circular saw blade used.
→ Check the setting according to section ⇨ 10.1.3. and correct it if necessary.

14.4.6 Checking the Push Stick

Check the condition of the push stick daily before starting work:

- The push stick must not show any cracks, bending or other damage.
- The geometric shape of the push stick must not be altered or impaired.
- A damaged, defective or deformed push stick may no longer be used and must be replaced immediately.

14.5 Checking the Rip Fence

Check the parallelism of the rip fence at regular intervals:

- Please read the section ⇨ 5.13.5 and adjust the fence according to section ⇨ 10.8.

14.6 Checking the Cross-Cut Fence Tape Measure

Check the tape measure of the cross-cut fence at regular intervals:

- Proceed as described in section ⇨ 10.6.1.

14.7 Changing and Tensioning the Drive Belt



Switch off the machine during belt replacement and retensioning and secure it against unauthorised restarting! Lock the main switch with a padlock!

The drive belt should be replaced in the event of excessive wear, frayed flanks, traces of oil, porosity or if cross-sectional fractures are present. Only use belts of the same type that you are replacing. The exact type designation is printed on the drive belt.

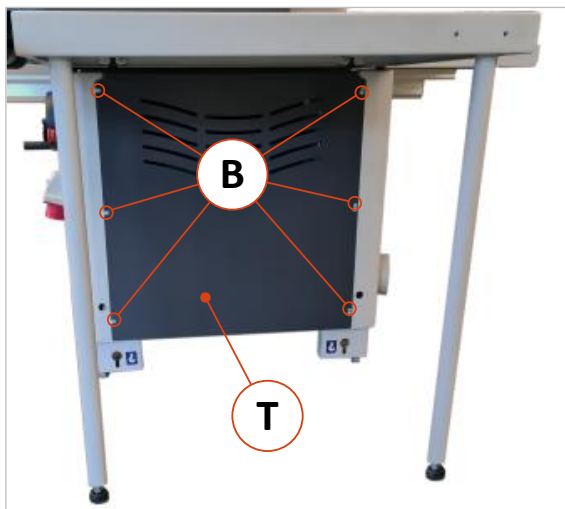

Figure 53: Open the service door

- Remove the 6 fastening screws (**B**) of the service door (**T**) on the backside.
- Remove service door (**T**) to access drive belt.

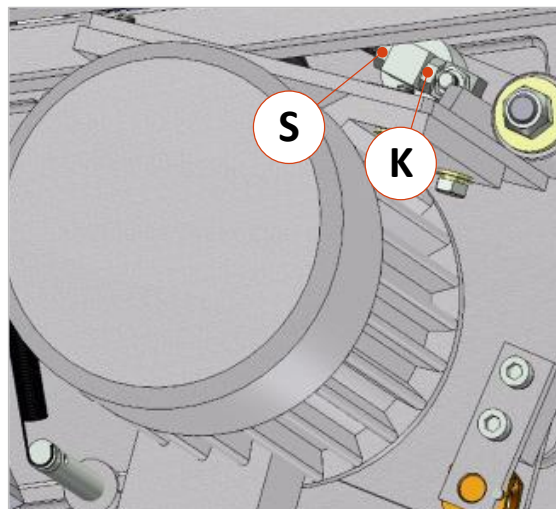

Figure 54: Tension drive belt

- Loosen the lock nut (**K**) and tension the belt with the tensioning nut (**S**).
- Tighten lock nut (**K**) and check belt tension according to section ⇒ 14.7.1.

After tensioning the belt, replace the service door (**T**).

Note: The flat belt installed in the machine for the optional scoring unit does not need to be tensioned, as it is automatically tensioned by a tensioning spring.

14.7.1 Checking the Drive Belt Tension

After the first 10 hours of operation and at regular six-month intervals thereafter, it is necessary to check the tension of the drive belt.

The correct pretension of the belt can be checked as follows:

- Press the drive belt (in the middle between the two belt pulleys) from above with a strong thumb pressure (approx. 2 kg).
- With correct pretension, the belt must only be able to be pushed downwards (**X**) by max. 5 mm.
- If a new belt is installed, it must only be possible to push it downwards (**X**) by max. 2 mm.

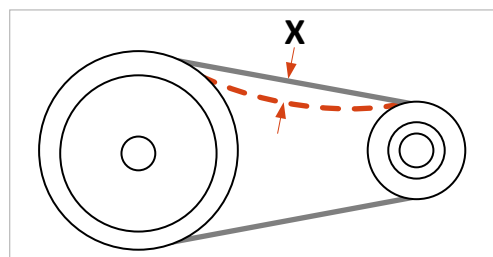

Figure 55: Checking the belt tension



Too low belt tension leads to increased wear or failure of the belt. Excessive belt tension can cause bearing damage to the drive axes.

14.8 Maintaining the Drive Belt

Contamination of the drive belt with oil, grease, solvents, paint, etc. must be avoided. Clean and dry the belt and pulley channels only with a soft brush or a clean cotton or paper towel. Do not use solvents or similar cleaning agents and never use water.



14.9 Taking the Machine out of Operation / Storage

- When putting the machine out of operation, switch off the electrical system.
- If the machine will not be used for a long time, clean the machine carefully after switching off the electrical system and treat the worktable and the other bare parts with an anti-corrosion agent.
- The machine must not be stored in a damp room and must be protected against the effects of the weather.

14.10 Defects and their Remedy

- In case of defects and pending repair work, switch off the machine, lock the main switch and disconnect the machine from the mains by pulling out the supply plug. Attach an appropriate sign, e.g. "Defect / Repair Work", to the machine so that it is clearly visible.

14.11 Average Situations / Emergencies

	<ul style="list-style-type: none"> • <i>In case of flooding of the work area, switch off the power supply immediately!</i> • <i>In case of fire, immediately switch off the power supply and use a class A fire extinguisher. Alternatively, fight the fire with a fire blanket. If the power cannot be switched off, you need a class C powder extinguisher.</i> • <i>Never extinguish burning electrical equipment with water!</i>
	<ul style="list-style-type: none"> • <i>Before the machine is put back into operation, it must be checked by a trained and approved technician.</i> • <i>The working area around the machine (see section ⇒ 6.3) always be clear.</i>
	<ul style="list-style-type: none"> • <i>The machine must not be used in potentially explosive atmospheres!</i>

15 Electrical Circuit Diagram

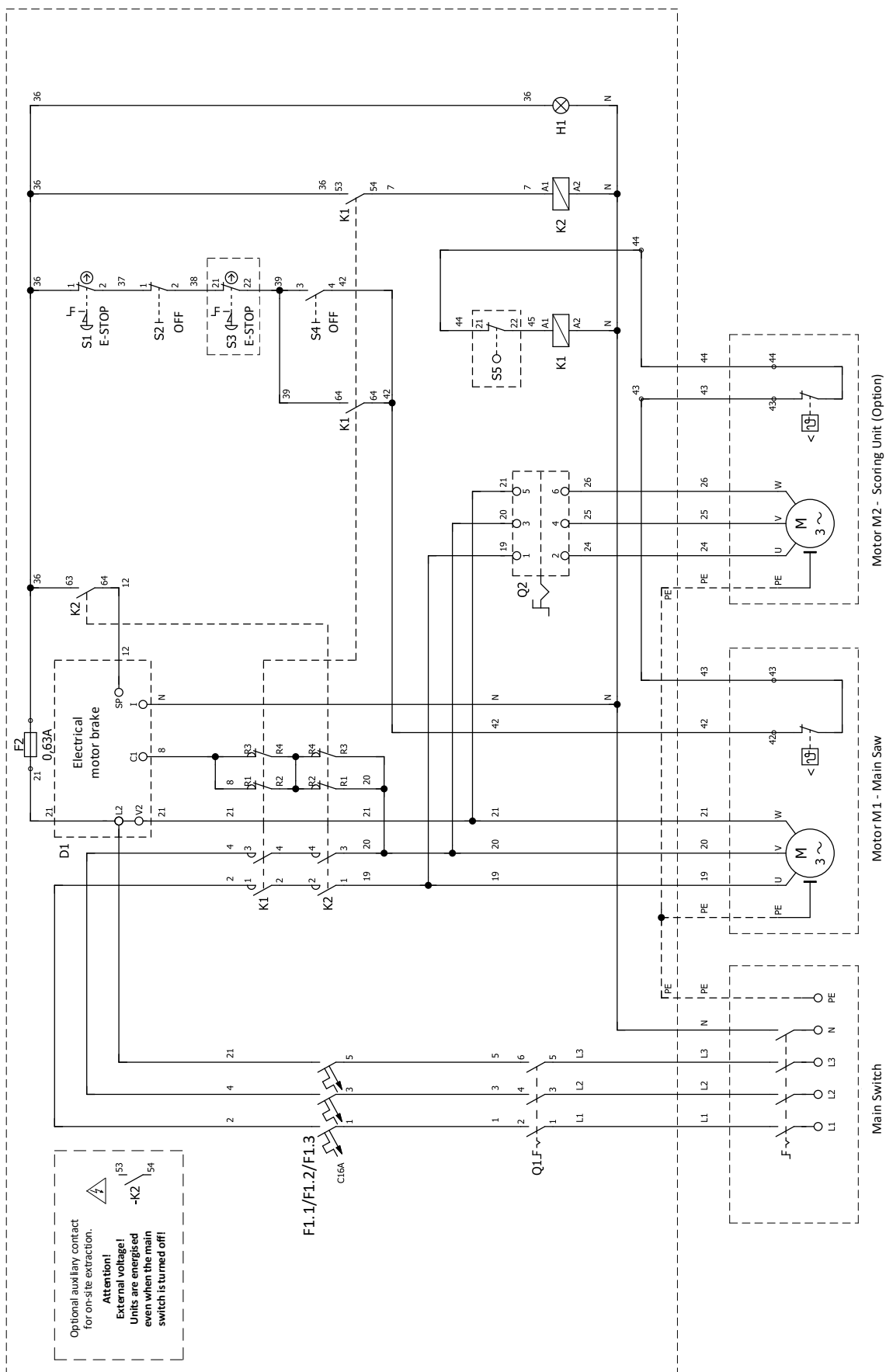



Figure 56: Electrical circuit diagram

16 Options and Accessories

	<p><i>Use only the tools, accessories and spare parts specified by the manufacturer. The use of other tools, accessories or spare parts may cause injury to persons and damage to the machine. The manufacturer accepts no liability for any damage resulting from the use of tools, accessories or spare parts not specified by the manufacturer or from additional components supplied by third parties!</i></p>
---	--

16.1 Circular Saw Blades

Article	Description	Art. No.
HW Point-Hollow Tooth Circular Saw Blade Ø 250 mm	SB = 3.2 mm, b = 2.2 mm, d = 30 mm Z/F = 48, for final cuts in board materials coated with plastic on both sides.	GU2037.250.30
HW Point-Hollow Tooth Circular Saw Blade Ø 250 mm	SB = 3.2 mm, b = 2.2 mm, d = 30 mm Z/F = 60, for final cuts in board materials coated with plastic on both sides.	GU2037.300.30
HW Saw Blade 2-piece Set in a Wooden Case (Premium 1)	Universal saw blade PI-100 "Piano-plus": Ø 303 x 3.2/2.2 x 30 mm Z 46 WZ Point-hollow saw blade „Classic“: Ø 303 x 3.2/2.2 x 30 mm Z 60 DH	GU2000.850.86
HW Saw Blade 2-piece Set in a Wooden Case (Premium 2)	Point-hollow saw blade: Ø 303 x 3.2/2.2 x 30 mm Z 60 DH Longitudinal cutting saw blade: Ø 300 x 3.2/2.2 x 30 mm Z 28 WZ	GU2000.850.87

16.2 Optional Accessories

Article	Description	Art. No.
Scoring Unit	Mechanically adjustable, 0.75 kW.	FKS6-315/2300-002
Overhead Saw Blade Guard, swivelling	Kreissägen-Oberschutzhaube* wegschwenkbar aus dem Arbeitsbereich (bis 1000 mm Schnittbreite).	FKS6-315/2300-003
Reinforced Motor	Motor 5.5 kW (7.5 HP) / 400V instead of 4.0 kW	FKS6-315/2300-004
Switch Contact for Extraction	Additional switching contact for automatic switching of the extraction system (on/off).	FKS6-315-005

*) Accessories for the overhead saw blade guard as well as other safety accessories can be found in the current [SI-TEC catalogue](#).

17 Disassembly and Scrapping

When dismantling and scrapping the machine, the current EU regulations or the respective regulations and laws of the country of operation, which are prescribed for proper dismantling and disposal, must be observed. The aim is to dismantle the machine and its various materials and components properly, to recycle all possible parts and to dispose of non-recyclable components in the most environmentally friendly way.

	<p>Please pay particular attention to</p> <ul style="list-style-type: none"> • <i>the dismantling of the machine in the working area</i> • <i>proper dismantling of the machine and accessories</i> • <i>a safe and proper removal of the machine</i> • <i>proper separation of all components and materials.</i>
---	--

When dismantling and disposing the machine, the laws and regulations in force at the place of use concerning health and environmental protection must be observed.

	<p>Remove all residues of oil, grease and other lubricants and have them disposed of properly by a qualified disposal company.</p>
---	---

When separating, disposing of or recycling the machine materials, comply with the environmental protection laws in force at the place of use regarding the disposal of industrial solid waste toxic and hazardous waste.

	<ul style="list-style-type: none"> • <i>Hoses and plastic parts as well as other components that are not made of metal must be dismantled and recycled or disposed of separately.</i> • <i>Electrical components such as cables, switches, connectors, transformers, etc. must be removed and (if possible) recycled or otherwise disposed of in a qualified manner.</i> • <i>Pneumatic and hydraulic parts such as valves, solenoid valves, pressure regulators, etc. must be removed and (if possible) recycled or otherwise disposed of in a qualified manner.</i> • <i>Dismantle the base frame and all metal parts of the machine and sort them according to material type. Metals can be melted down and recycled.</i>
--	--

In the event of improper disposal of lubricants, the following residual risks to the environment and health exist:

	<p>Pollution of the environment by seepage into groundwater or sewage system.</p>
---	--

	<p>Poisoning of the personnel contracted for the disposal.</p>
---	---

Note: The disposal of lubricants considered toxic and hazardous must be carried out in accordance with the regulations and laws in force at the respective place of use. Only qualified disposal companies that have the appropriate permits for the disposal of used oil and lubricants are to be commissioned with the disposal.

CE EU - Declaration of Conformity

in accordance with the EU Machinery Directive 2006/42/EC Annex II A

The manufacturer,

HOKUBEMA Maschinenbau GmbH
Graf-Stauffenberg-Kaserne
Binger Str. 28 | Halle 120
DE 72488 Sigmaringen (Germany)

Phone: +49 (0) 7571 / 755 - 0
Fax: +49 (0) 7571 / 755 - 222

hereby declares that the manufactured machine

Sliding Table Saw WOODPECKER FKS6-315/2300

Machine-No.:

Year of manufacture:

in the version provided complies with the following directives:

- Machinery Directive 2006/42/EC

- EMC Directive 2014/30/EU

Mr. Andreas Ganter, Graf-Stauffenberg-Kaserne, Binger Str. 28 | Halle 120,
72488 Sigmaringen (Germany), is authorised to compile the technical documentation.

Sigmaringen, 06.09.2022

.....



.....

Reinhold Beck
Business Manager