

Mobile Lifter ML-120

**Ergonomic lifting device
with radio remote control**

For convenient handling of large-format panels, completely without the use of your own physical strength.

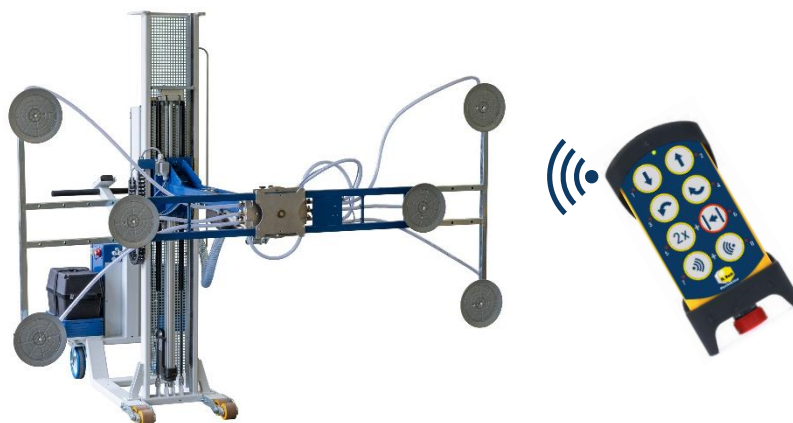

Mobile Lifter ML-120 Technical specifications

Article number	350.100.00
Height adjustment range	up to max. 1600 mm (electromotive)
Tilt range (vertical)	-90° ... 0 ... +90° (electromotive)
Swivel range (horizontal)	-85° / 0° / +85° (manually) positions lockable
Rotation range (frontal)	0 ... 270° (manually) lockable in 90° steps
Lifting and load capacity	max. 120 kg
Panel size to be lifted	max. 2,100 x 3,200 mm
Actuators	2 pcs. 24 VDC linear actuators Linak type LA 36
Front castors	4 Ø 82 mm lift carriage castors (rigid)
Rear castors	2 Ø 200 mm swivel castors with brake
Dimensions	L x H x W = 2680 x 2090 x 1710 mm (dimensional drawing see ⇒ back page)
Net weight	approx. 440 kg
Wireless Control Unit	
Components	1 piece radio remote control as transmitter + 1 stationary receiver with antenna
Frequency band	433.075 - 434.75 MHz
Operating time remote control	approx. 24 hours (for continuous operation)
Transmitter power supply	integrated lithium-ion battery, rechargeable via fixed charging station
Charging unit power supply	24 VDC from ML-120 battery unit (see below)
Remote control buttons	4 function button pairs + 1 combined off/emergency stop button
Receiver power supply	24 VDC from ML-120 battery unit (see below)
Safety levels	EN 61508 SIL3 and EN ISO 13849 PLe (emergency stop function)
Protection class	Transmitter: IP65 Charging unit for transmitter: IP40 Receiver: IP66
Vacuum Unit	
Vacuum generator	24 VDC / 500 W glanded pump
Product info (pump)	Manufacturer: Schmalz Type: EVE-TR 8 24V-DC F
Pumping speed	9.70 m ³ /h
Sound level	60.5 dB(A)
Vacuum pad	6 round vacuum suction pads (Ø 210 mm), 4 of them shiftable
Connection type	G1/2"-IG
Product info (vacuum pads)	Manufacturer: Schmalz Type: SPU 210 NBR-55 G1/2-IG
Vacuum generator	24 VDC / 500 W glanded pump
Battery Unit	
Batteries	2 pieces maintenance-free 12 V lead-acid batteries (connected in series)
Product info	Manufacturer: Landport Type: EV12-110
Output voltage	24 VDC
Battery capacity	110 Ah (approx. 10 hours)
Operating temperature	Discharge: -20 ... +60° C Charging: 0 ... +50° C Storage: -20 ... +60° C
Charger make	Manufacturer: S.P.E. Type: CBHF2 24-30
Connection charger	Plug-in connector with reverse polarity protection

Adjustment options

To ensure that the Mobile Lifter can be used as flexibly as possible in panel handling, it has various adjustment options, which are carried out either manually or by electric motor.

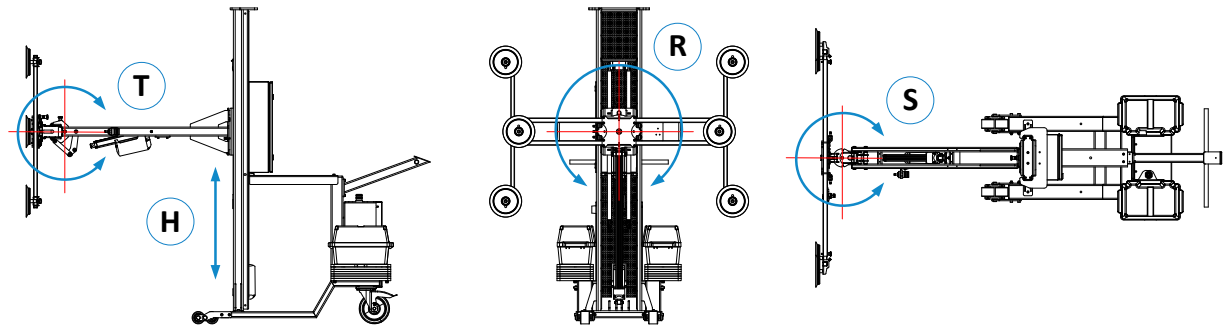

Pos.	Designation	Description	Type of adjustment
H	Lifting height (vertical)	Height adjustment range	motorised, variable up to max. 1600 mm
T	Tilt (vertical)	Tilt range	motorised, variable -90° ... 0 ... +90°
R	Rotate (frontal)	Rotation range	manual 0 ... 270°, lockable in 90° steps
S	Swivel (horizontal)	Swivel range	manual -85° ... 0° ... +85°, lockable in steps

Dimensions

Front view:

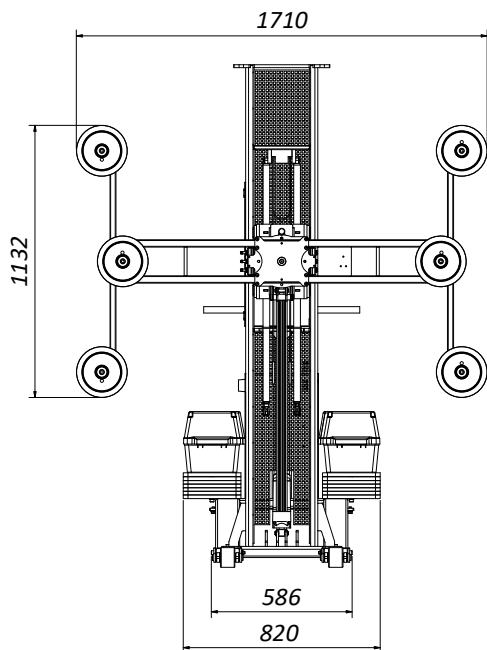

Side view:

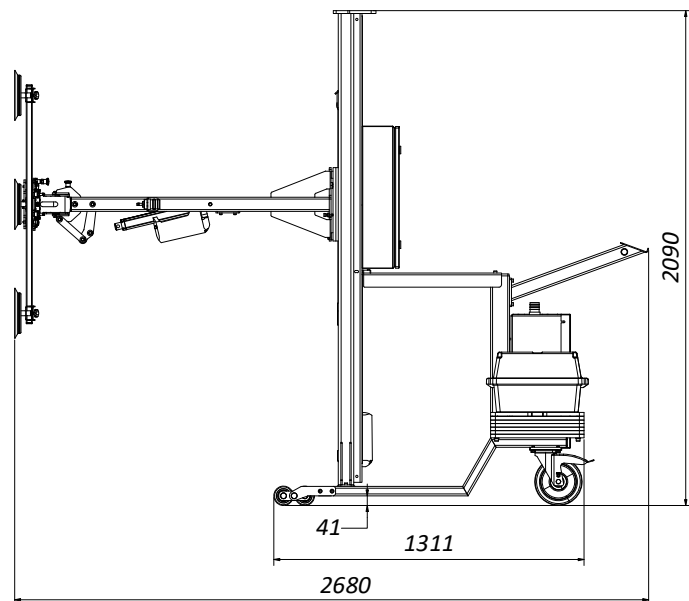

Requirements for the installation site

Space requirements (L x W x H)	approx. 2700 x 2200 x 1750 mm
Load bearing capacity of the base	concrete of classification B 15
Ground condition	level, smooth, non-slip and tilt-free

Reinhold Beck Maschinenbau GmbH

Im Grund 23 | DE -72505 Krauchenwies (Germany)

Phone: +49 (0) 7576 / 962 978 - 0 | Fax: +49 (0) 7576 / 962 978 - 90

E-Mail: info@beck-maschinenbau.de | Web: <https://www.beck-maschinenbau.de>