

116 | 10

Slot Drilling and Mortising Machine



Technical Specifications

Drilling depth:	max. 145 mm
Mortise length:	max. 240 mm
Height adjustment:	135 mm
Drill chuck:	three-jaw chuck, capacity 5 ... 20 mm (collet optionally)
Workpiece clamping:	2 eccentric clamps (optionally pneumatic safety clamping cylinders)
Drilling unit adjustment:	Two-lever operation (optionally single-lever operation)
Table height:	910 mm
Table top size:	700 x 380 mm
Total height:	approx. 1250 mm (standard version)
Workpiece stop:	max. 150 mm
Mitre fence:	45° / 22.5° (attachable)
Dowel drilling unit:	16, 22, 25 or 32 mm via raster rod
Motor voltage:	400 V / 50 Hz
Motor power:	1.3 kW / 1.8 HP (1500 rpm) resp. 1.7 kW / 2.3 PS (3000 rpm) Option: 1.7 kW / 2.3 PS (100 - 2870 rpm "variable speed control")
Motor brake	Mechanical (electrical with option "variable speed control")
Protection class:	IP54
Space requirement:	refer to page 2
Weight:	approx. 200 kg net (seaworthy packed approx. 320 kg)
Laser device (option):	Laser class 1M
Supply cable:	Cu, 5-wire (the cross-section must be determined on site by a qualified electrician!)
Connection phases:	L1 L2 L3 N PE
Fuse:	16 A slow
Suction nozzle:	1 x Ø 100 mm
Extraction Power:	approx. 565 m ³ /h at 20 m/s (dry chips)
Signal Generator Lines for Extraction Unit:	Terminal 1 + 2 on switch S1, see circuit diagram



- Caution: The regulations of the local EVU apply.
- Checking the impedance of the fault loop and the suitability of the overcurrent protection devices must be carried out at the installation site of the machine.
- The electrical connection may only be carried out by an authorised electrician.
- The electrical circuit diagram can be found in the motor cover behind the main switch.

Emission Values according to DIN 45635 part 1662

Workplace-related Noise Emission Value ¹	Idle: 68.3 dB(A) Working: 74.3 dB(A)
Workplace-related Dust Emission Value ^{2 3}	0.25 mg/m ³



As soon as the workplace-related noise emission values of the machine exceed 85 dB(A), suitable hearing protection must be made available to the personnel!

¹ Series scattering of + 3 dB(A) can occur | ² Permissible 0.25 mg/m³ air | ³ Dust emission values determined acc. to GS-HO-05

Dimensions and Working Area

Top View:

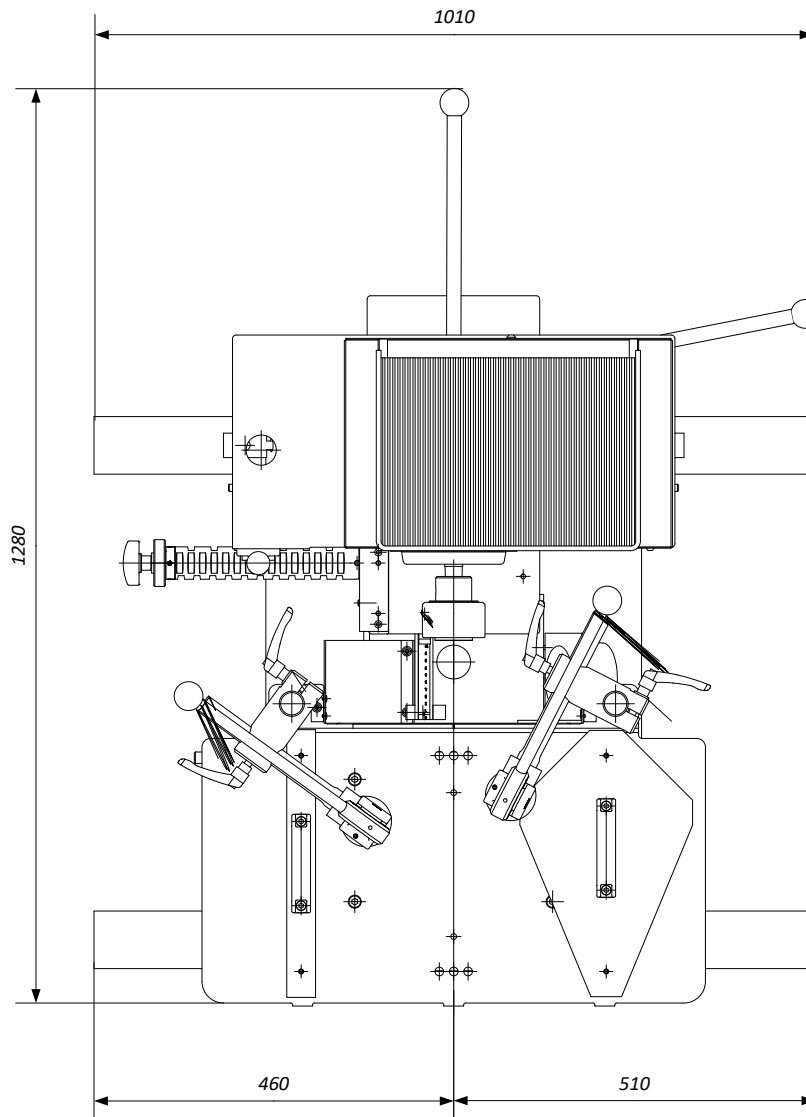

Top View:

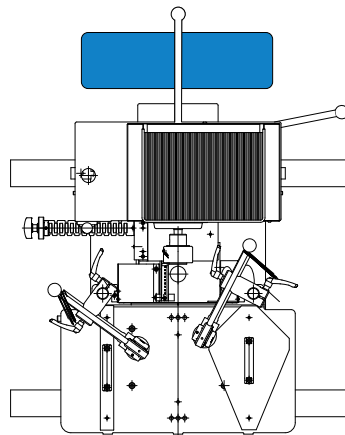

Space requirement: approx. 1810 x 2080 mm

The effective space requirement usually depends on the dimensions of the machine and the dimensions of the workpieces to be machined.

In general, provide sufficient space around the machine and also calculate the required workplace for the operating personnel and for the infeed and outfeed of the workpieces.

 = Working Area

HOKUBEMA Maschinenbau GmbH

Graf-Stauffenberg-Kaserne, Binger Str. 28 | Halle 120

DE 72488 Sigmaringen (Germany) | Tel. +49 07571 755-0

E-Mail: info@hokubema-panhans.de | Web: <https://hokubema-panhans.de>