

690 | 200 Sliding Table Saw



Technical Specifications

Table Size:	1200 x 665 mm
Table Height:	900 mm (± 20 mm)
Tilt Range of the Sawblade:	0° - 46°
Sawblade Speed:	3000/4000/5000/6000 rpm (switchable)
Sawblade Diameter:	max. 450 mm (400 mm retractable under the table)
Bore Ø Main Saw:	30 mm
Bore Ø Scoring Saw / Option Quickstep:	22 mm / 50 mm (sawblade diameter max. 125 mm)
Angle / Mitre Fence:	on both sides up to 46°
Cutting Height:	max. 155 mm at 90° / max. 105 mm at 46°
Cutting Length / Slide Length:	3200 mm / 3200 mm
Cutting Width at the Rip Fence:	1250 mm
Cutting Length at the Crosscut Fence:	max. 3200 mm
Table Extension:	plus 750 x 655 mm
Table Widening:	1430 x 940 mm
Drive Motor Power:	5.5 kW (7,5 HP) optionally 7.5 kW (10 HP)
Protection Class:	IP54
Space Requirement:	7000 x 6500 mm
Net Weight:	approx. 1150 kg
Ground Load:	4.0 kg/cm ²
Voltage:	400 V / 50 Hz
Supply Cable:	Cu, 5-wire The cross-section must be determined on site by a qualified electrician!
Connecting Phases:	L1 L2 L3 N PE
Fuse Protection:	5.5 kW: 25 A 7.5 kW: 32 A or 35 A
Extraction Unit:	Total connection Ø 140 mm negative pressure approx. 1200 Pa
Extraction Capacity:	approx. 1450 m ³ /h at 20 m/s (dry chips)
Signal generator wire for extraction unit:	Terminal 03 + 04 on contactor K2, see wiring diagram



- Caution: The regulations of the local EVU apply.
- Checking the impedance of the fault loop and the suitability of the overcurrent protection devices must be carried out at the installation site of the machine.
- The electrical connection may only be carried out by an authorised electrician.
- The circuit diagram can be found in the machine column behind the control panel or optionally in the control cabinet.

Emission Values according to EN 1870-1 ¹

Workplace-related emission levels in dB(A):	87 (idle) 85 (machining)
Sound power level in dB(A):	99 (idle) 101 (machining)
Workplace-related dust emission value ^{2 3} :	The determined values comply with the required assessment values for the "GS wood dust test" mark by the German Woodworkers trade association.



The noise emission values of the machine partly exceed 85 dB(A)!
Therefore, suitable hearing protection must be provided to the personnel!

¹ Uncertainty allowance K = 4 dB(A) | ² Permissible: 2.0 mg/m³ air | ³ Dust Emission Values: Determined acc. to GS-HO-05

Dimensions

Top View:

Sliding table

	Table length /	Cutting length
Option	2000 mm /	2000 mm
Option	2600 mm /	2600 mm
Standard	3200 mm /	3200 mm
Option	3800 mm /	3800 mm

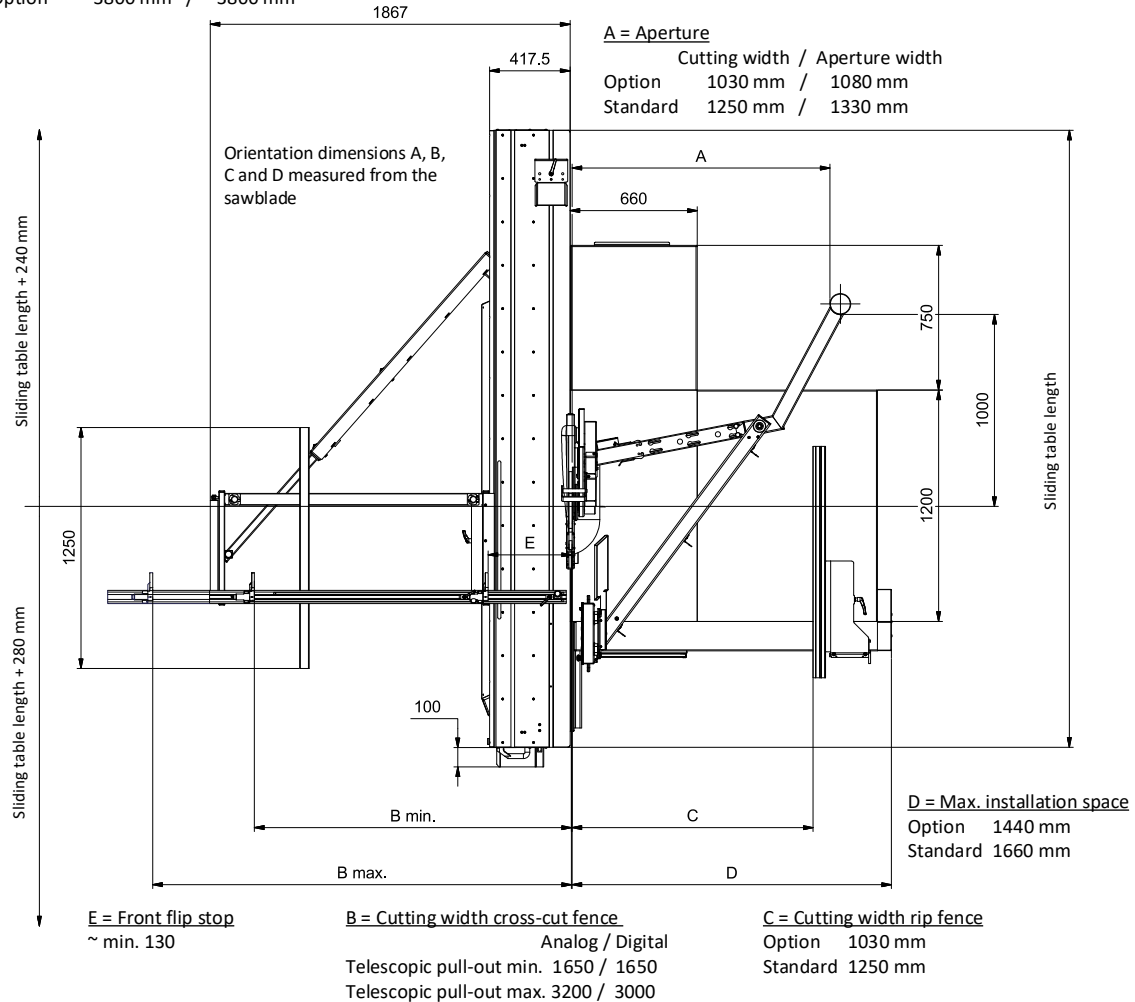

Front View:

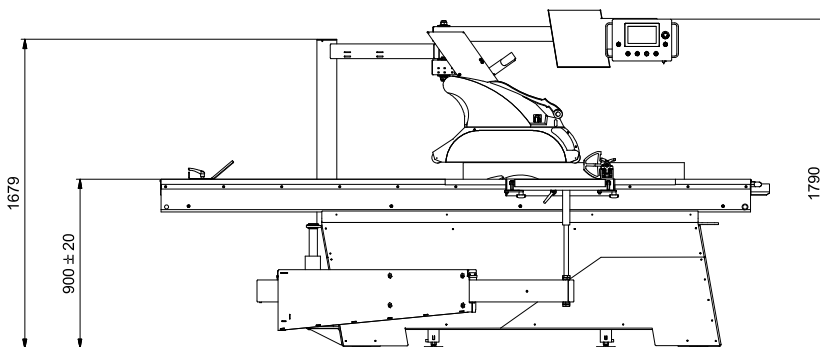

Working Areas:

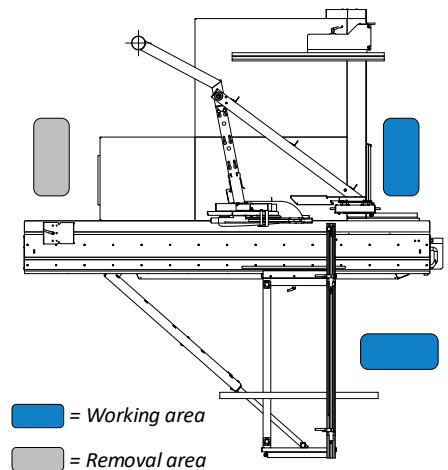

HOKUBEMA Maschinenbau GmbH

Graf-Stauffenberg-Kaserne, Binger Str. 28 | Halle 120
DE 72488 Sigmaringen (Germany) | Tel. +49 07571 755-0

E-Mail: info@hokubema-panhans.de | Web: <https://hokubema-panhans.de>

Figures are for illustration purposes only and may deviate from the current status | Subject to modifications © Hokubema Maschinenbau GmbH