

## BSB 900

### Bandsaw Machine



### Technical Specifications

Wheel Diameter:	900 mm
Saw Blade Length:	min. 6160 mm / max. 6260 mm
Saw Blade Width:	15 - 45 mm (10 - 45 mm with special crowned surface)
Saw Blade Thickness:	0.8 - 0.9 mm
Surface Width:	47 mm
Saw Blade Speed:	1720 m/min
Cutting Height:	max. 550 mm
Cutting Width:	max. 880 mm
Table Size:	830 x 1275 mm
Table Dimensions:	1015 mm
Bandsaw Blade Guide:	APA 2 (Size 2)
Laser Cut Position Indicator (Option):	Laser class 1M
Motor Power:	Standard: 5.5 kW (7.5 HP)   Option: 7.5 kW (10 HP)
Motor Brake:	mechanical (electrical with option "Variable Bandsaw Blade Speed")
Protection Class:	IP54
Spare Requirement:	see next page
Net Weight:	approx. 700 kg
Voltage:	400 V / 50 Hz
Supply Cable:	Cu, 5-wire (Cross-section must be determined on site by a qualified electrician!)
Connecting Phases:	L1   L2   L3   N   PE
Fuse Protection:	20 A with 5.5 kW or 25 A with optional 7.5 kW motor
Extraction:	2 x Ø 120 mm   Volume flow: 1140 m <sup>3</sup> /h
Extraction Power:	approx. 1450 m <sup>3</sup> /h at 20 m/s (dry chips)
Signal Generator Lines for Extraction Unit:	Terminal 163 + 164 on actuator K1, see circuit diagram



- Caution: The regulations of the local EVU apply.
- Checking the impedance of the fault loop and the suitability of the overcurrent protection devices must be carried out at the installation site of the machine.
- The electrical connection may only be carried out by an authorised electrician.
- The circuit diagram can be found in the machine column behind the control panel or optionally in the control cabinet.

### Emission Values according to EN ISO 3746:2010

Noise Level <sup>1</sup>	Idle: 85 dB(A)   Working: 97 dB(A)
Emission Pressure Level at the Workplace <sup>1</sup>	Idle: 68 dB(A)   Working: 89 dB(A)
Workplace-related Dust Emission Value <sup>2 3</sup>	0.75 mg/m <sup>3</sup>



As soon as the workplace-related noise emission values of the machine exceed 85 dB(A), suitable hearing protection must be made available to the personnel!

<sup>1</sup> Uncertainty allowance K = 4dB | <sup>2</sup> Permissible: 2.0 mg/m<sup>3</sup> air | <sup>3</sup> Dust Emission Values: Determined acc. to GS-HO-05

## Dimensions and Working Area

Front View:

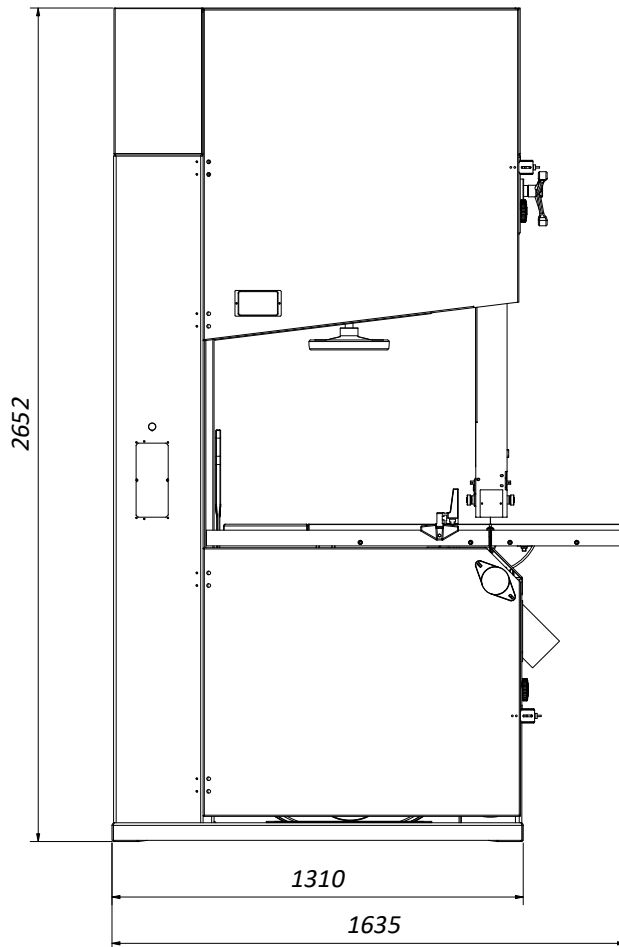

Side View:

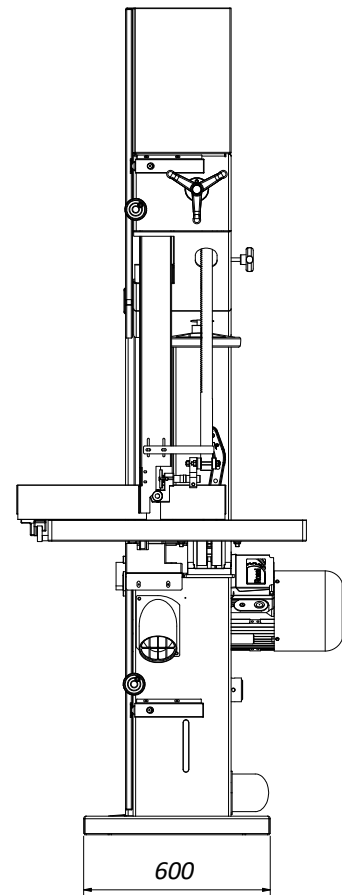

Draufsicht:

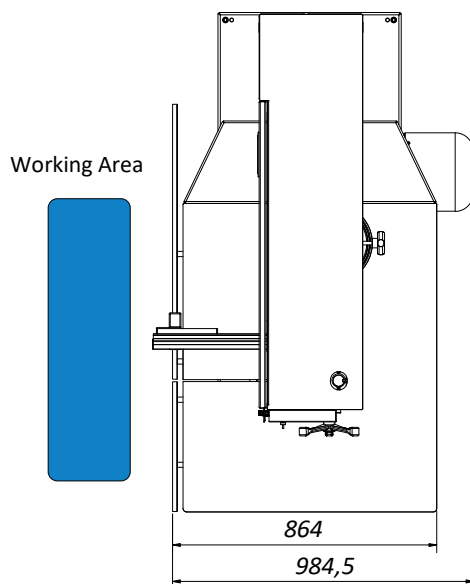

Space Requirement:

The effective space requirement usually depends on the dimensions of the machine and the dimensions of the workpieces to be machined.

In general, provide sufficient space around the machine and also calculate the required workplace for the operating personnel and for the infeed and outfeed of the workpieces.

**HOKUBEMA Maschinenbau GmbH**

Graf-Stauffenberg-Kaserne, Binger Str. 28 | Halle 120

DE 72488 Sigmaringen (Germany) | Tel. +49 07571 755-0

E-Mail: [info@hokubema-panhans.de](mailto:info@hokubema-panhans.de) | Web: <https://hokubema-panhans.de>