

Band Resaws TBS 800R TBS 900R



Technical Specifications	Model TBS 800R	Model TBS 900R
Wheel dimensions	2 x Ø 800 mm (70 mm wide)	2 x Ø 900 mm (70 mm wide)
Wheel crowning	0.2 mm (centre)	0.2 mm (centre)
Cutting height	max. 460 mm	max. 580 mm
Cutting width	max. 785 mm	max. 880 mm
Saw blade length	max. 5730 mm	max. 6260 mm
Saw blade width	80 mm	80 mm
Feed unit (standard)	2.5 - 40 m/min (10-step)	2.5 - 40 m/min (10-step)
Feed unit (optional)	2.0 - 30 m/min (variable)	2.0 - 30 m/min (variable)
Operating pressure for feed	6 - 8 bar	6 - 8 bar
Air consumption	30 l/min	30 l/min
Table size	1200 x 925 mm	1350 x 925 mm
Table height	930 mm	1015 mm
Motor (standard)	11 kW / 15 HP (400V / 50 Hz)	11 kW / 15 HP (400V / 50 Hz)
Motor (optional)	15 kW / 20 HP (400V / 50 Hz)	15 kW / 20 HP (400V / 50 Hz)
Protection class	IP 54	IP 54
Motor brake	mechanical	mechanical
Saw blade speed	1800 m/min	1820 m/min
Supply cable	Cu, 5-core. The cross-section must be determined on site by a qualified electrician!	
Connecting phases	L1 L2 L3 N PE	L1 L2 L3 N PE
Fuse protection	11 kW: 32 A slow / 15 kW: 50 A slow	11 kW: 32 A slow / 15 kW: 50 A slow
Space requirement (H x W x D)	approx. 2500 x 2640 x 4730 mm	approx. 2700 x 2810 x 4730 mm
Suction nozzles	2 x Ø 120 mm	2 x Ø 120 mm
Weight	approx. 820 kg	approx. 920 kg
Air speed at the port	min. 20 m/s	min. 20 m/s
Minimum volume flow	1440 m ³ /h at 20 m/s	1440 m ³ /h at 20 m/s
Negative pressure at the port	approx. 950 Pal at 20 m/s	approx. 950 Pal at 20 m/s
Signal generator line (extraction)	Terminal 83 + 84 on contactor -Q2	Terminal 83 + 84 on contactor -Q2



- Caution: The regulations of the local power supply company apply.
- Checking the impedance of the fault loop and the suitability of the overcurrent protection devices must be carried out at the installation site of the machine.
- The electrical connection may only be carried out by an authorised electrician.
- The circuit diagram can be found in the control cabinet at the rear of the machine.

Noise Emission Values acc. to EN 1870-1

Uncertainty allowance K = 4 dB(A)

Workplace-related emission levels in dB(A):	Infeed: 78 (idle) 91 (machining)	Removal: 79 (idle) 96 (machining)
Sound power level in dB(A):	93 (idle) 104 (machining)	

If the machine is correctly connected to a sufficiently powerful extraction system (air speed min. 20 m/s in the overall connection), it can be assumed that the 2.0 mg/m³ limit value for wood dust at the workplaces will be permanently complied with.



The noise emission values of the machine partly exceed 85 dB(A)!
Therefore, suitable hearing protection must be provided to the personnel!

Dimensions and Working Areas

Dimensions TBS 800R:

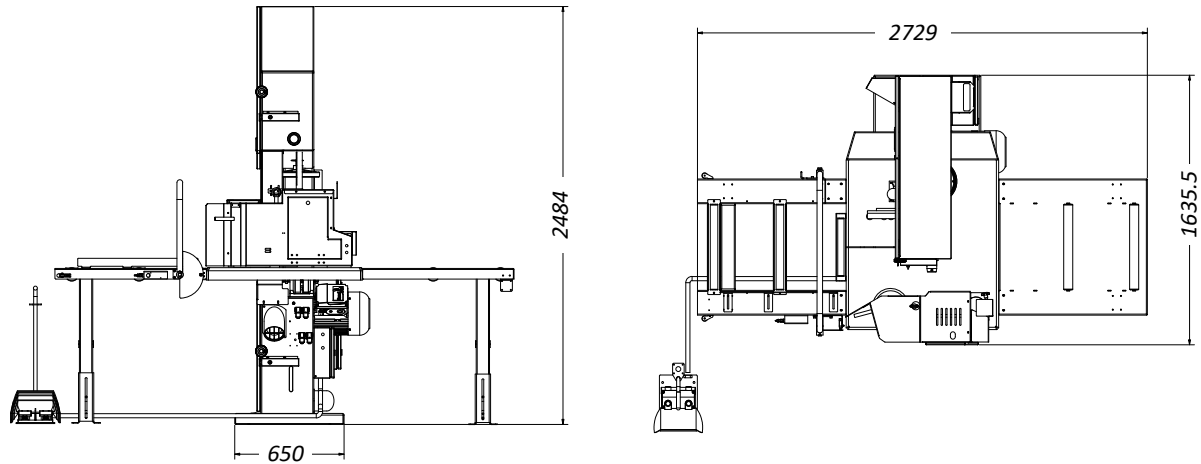

Dimensions TBS 900R:

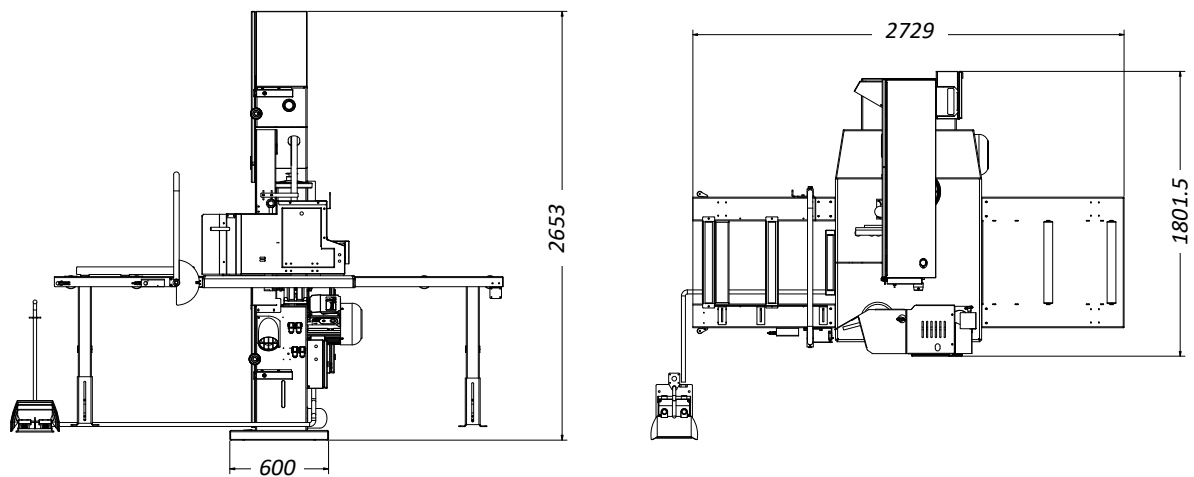

Working Areas:

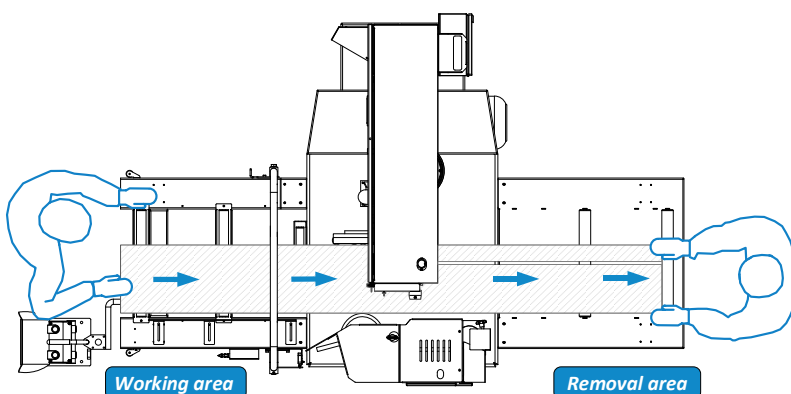

Effective Space Requirement:

The effective space requirement depends on the external dimensions of the machine and the dimensions of the workpieces to be processed. Generally provide sufficient space around the machine and also calculate the space required for adjustment, repair and maintenance work, the operating and auxiliary personnel as well as for feeding and removal of long workpieces.

Based on the external dimensions of the machine, the possible workpiece dimensions as well as the calculated space for feeding and removing the workpieces, a free space of at least 1.0 m must be ensured around the machine.

HOKUBEMA Maschinenbau GmbH

Graf-Stauffenberg-Kaserne, Binger Str. 28 | Halle 120
DE 72488 Sigmaringen (Germany) | Tel. +49 07571 755-0

E-Mail: info@hokubema-panhans.de | Web: <https://hokubema-panhans.de>