

INSTALLATION INSTRUCTIONS

TM-300

Electronic High End Key System
for Machine Releases



Beck Kommunikationselektronik

Bodenseeallee 18 | DE 78333 Stockach | Tel.: +49 7771 8068668
E-Mail: mail@beck-electronics.com | Web: www.beck-electronics.com

Table of Contents

1	General	3
2	Safety	3
2.1	Safety Precautions	3
3	Installation	4
3.1	Power Supply Voltage	4
3.2	Connections	4
3.3	Pin Assignment	4
3.4	Connecting the TM-300	4
3.4.1	RJ45 Network Connection	5
3.5	External Power Supply Unit 24 VDC / 1 A	5
3.6	Control of a Contactor with 24 V Coil	5
3.7	Block Diagram	5
4	Circuit Diagram	6

List of Images

Figure 1:	12-pin screw terminal	4
Figure 2:	Example wiring „Out 1“ (pin 8)	4
Figure 3:	External 24 VDC power supply unit	5
Figure 4:	External contactor with 24 V coil	5
Figure 5:	Block diagram	5
Figure 6:	Circuit diagram of TM-300	6

1 General

The TM-300 unit is supplied as standard in a panel housing. The cut-out dimensions correspond to a standard common in mechanical engineering. Panel cutout: W x H = 67 x 46 mm resp. 2.64 x 1.81".

The panel housing is inserted from the front into the prepared panel cut-out and clamped against the panel from the rear by using the enclosed clamping brackets.









Optionally, a built-on housing is available, which can be mounted on a machine surface. Dimensions of the built-on housing: W x H x D = 107 x 56 x 110 mm resp. 4.21 x 2.20 x 4.33".

2 Safety



The TM-300 unit may only be installed by authorized personnel. Before the TM-300 can be installed and commissioned, all external components to be connected to the TM-300 must be de-energized resp. disconnected from the power supply.

2.1 Safety Precautions

-  During installation, the accident prevention regulations of the responsible regional/national authorities must be observed.
-  We do not assume any warranty and liability for personal or material damages caused by incorrect application or by failure to follow these operating instructions. In such cases, any warranty claim expires!
-  For safety reasons, unauthorized modification and/or alteration of the device is not permitted.
-  Installation of the device may only be carried out by authorized personnel.
-  Improper installation can damage or destroy both the TM-300 and all connected external devices.
-  This is also associated with dangers such as short circuit, electric shock or fire hazard.
-  Do not use or install your TM-300 device in potentially explosive environments.
-  The device corresponds to the current state of the art. The device may present residual hazards if it is installed or put into operation unqualified.

3 Installation

3.1 Power Supply Voltage

The TM-300 can be supplied with a DC voltage of 10 ... 28 VDC. A commercially available power supply unit with a 24 VDC output and 1 A is recommended.

3.2 Connections

The connections are made via the pluggable 12-pin screw terminal strip on the rear of the device. The screw terminal strip has two screws on the side which serve as strain relief for the connector.

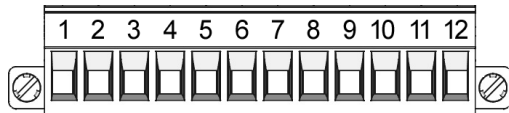

Figure 1: 12-pin screw terminal

3.3 Pin Assignment

Pin No.	Function / Signal
1	0 V (GND)
2	Screen / shield
3	+24 VDC power supply
4	RxD
5	TxD
6	Prog EN
7	GND
8	Out 1
9	Out 2
10	Out 3
11	Out 4
12	Out 5 (Master Key)

} *Special parameter
P07 (TM-100 Mode)*

Table 1: Pin assignment

3.4 Connecting the TM-300

The screw terminals of the plug connector are designed for cables with a cross-section of 0.5 mm² (max. 0.75 mm²). The figure below shows an example wiring with connected digital output "Out 1" and the power supply voltage.

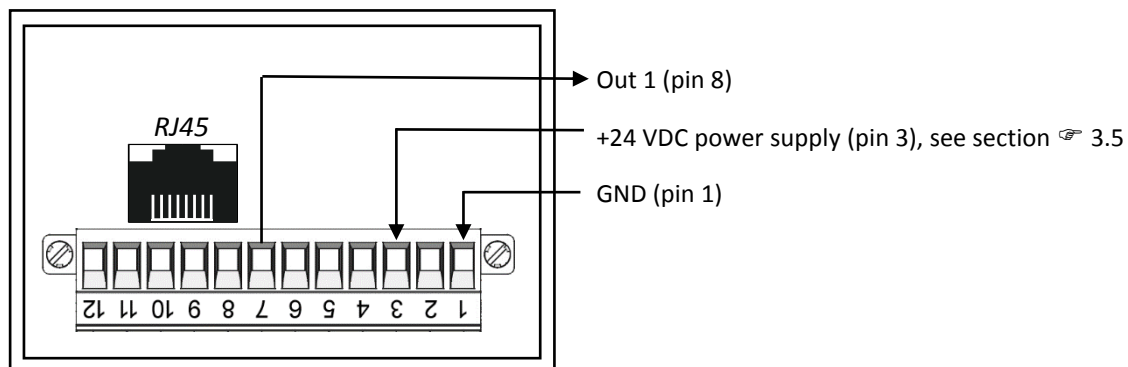

Figure 2: Example wiring „Out 1“ (pin 8)

3.4.1 RJ45 Network Connection

To connect the TM-300 to the Modbus TCP network via the RJ45 socket, a commercially available network cable of at least Cat 5e must be used.

3.5 External Power Supply Unit 24 VDC / 1 A

To power the TM-300 device, an external power supply unit is required

- The external power supply unit is connected on the primary side to a 115 or 230 VAC voltage.
- The secondary 24 VDC output is connected to the TM-300 device for power supply.

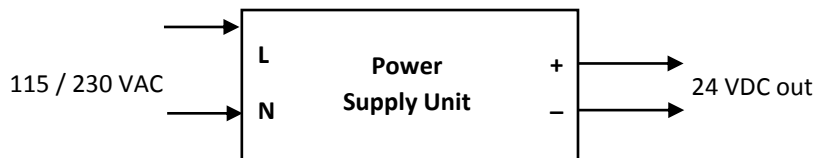

Figure 3: External 24 VDC power supply unit

3.6 Control of a Contactor with 24 V Coil

With the digital outputs of the TM-300, e.g. "Out 1" (TM-300 pin 8, see section 3.4) an external contactor with a 24 VDC coil can be controlled directly.

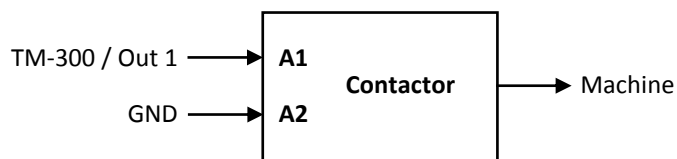

Figure 4: External contactor with 24 V coil

3.7 Block Diagram

The following block diagram results from the components described in the previous sections:

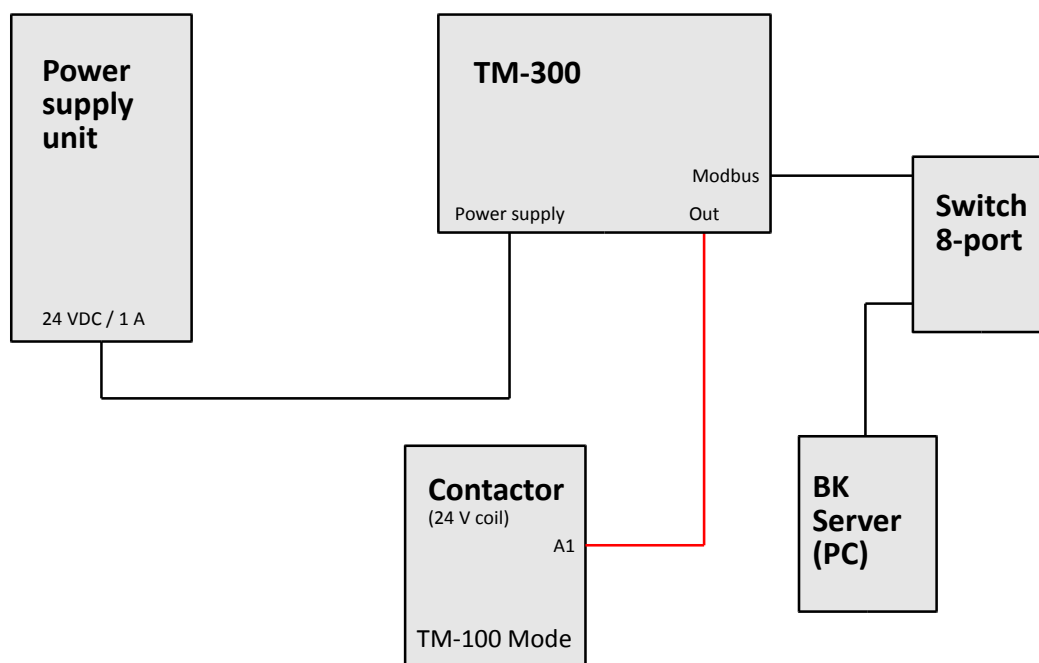

Figure 5: Block diagram

4 Circuit Diagram

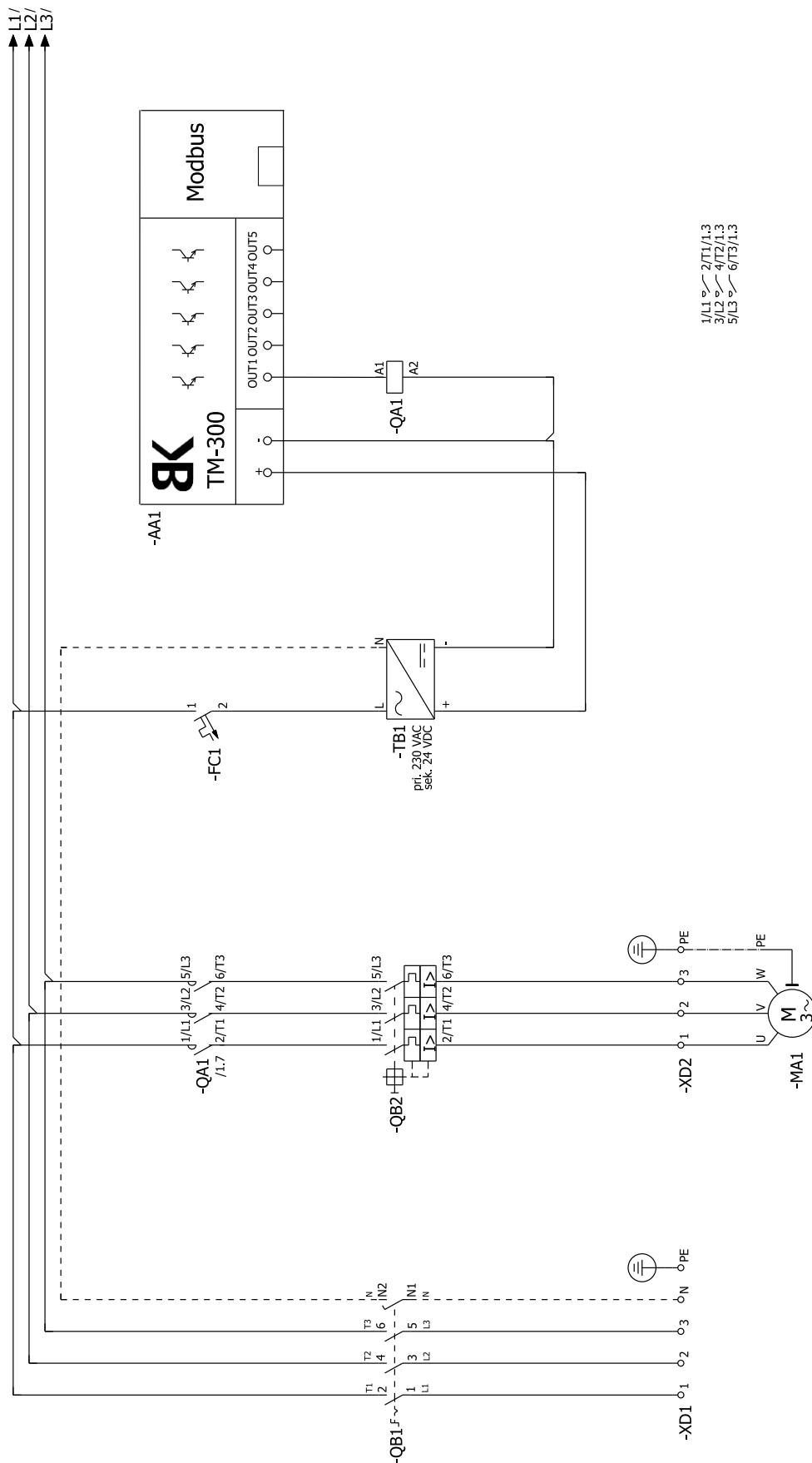

Figure 6: Circuit diagram of TM-300